

# **Instruction Manual**

**Tektronix**

**LPB 1300 & LPB 1550  
Tunable Laser Sources**

**071-0587-00**

**CE**

Copyright © Tektronix, Inc. All rights reserved.

Tektronix products are covered by U.S. and foreign patents, issued and pending. Information in this publication supercedes that in all previously published material. Specifications and price change privileges reserved.

Printed in the U.S.A.

Tektronix, Inc., P.O. Box 1000, Wilsonville, OR 97070-1000

TEKTRONIX and TEK are registered trademarks of Tektronix, Inc.

## WARRANTY

Tektronix warrants that the products that it manufactures and sells will be free from defects in materials and workmanship for a period of one (1) year from the date of shipment. If a product proves defective during this warranty period, Tektronix, at its option, either will repair the defective product without charge for parts and labor, or will provide a replacement in exchange for the defective product.

In order to obtain service under this warranty, Customer must notify Tektronix of the defect before the expiration of the warranty period and make suitable arrangements for the performance of service. Customer shall be responsible for packaging and shipping the defective product to the service center designated by Tektronix, with shipping charges prepaid. Tektronix shall pay for the return of the product to Customer if the shipment is to a location within the country in which the Tektronix service center is located. Customer shall be responsible for paying all shipping charges, duties, taxes, and any other charges for products returned to any other locations.

This warranty shall not apply to any defect, failure or damage caused by improper use or improper or inadequate maintenance and care. Tektronix shall not be obligated to furnish service under this warranty a) to repair damage resulting from attempts by personnel other than Tektronix representatives to install, repair or service the product; b) to repair damage resulting from improper use or connection to incompatible equipment; c) to repair any damage or malfunction caused by the use of non-Tektronix supplies; or d) to service a product that has been modified or integrated with other products when the effect of such modification or integration increases the time or difficulty of servicing the product.

**THIS WARRANTY IS GIVEN BY TEKTRONIX IN LIEU OF ANY OTHER WARRANTIES, EXPRESS OR IMPLIED. TEKTRONIX AND ITS VENDORS DISCLAIM ANY IMPLIED WARRANTIES OF MERCHANTABILITY OR FITNESS FOR A PARTICULAR PURPOSE. TEKTRONIX' RESPONSIBILITY TO REPAIR OR REPLACE DEFECTIVE PRODUCTS IS THE SOLE AND EXCLUSIVE REMEDY PROVIDED TO THE CUSTOMER FOR BREACH OF THIS WARRANTY. TEKTRONIX AND ITS VENDORS WILL NOT BE LIABLE FOR ANY INDIRECT, SPECIAL, INCIDENTAL, OR CONSEQUENTIAL DAMAGES IRRESPECTIVE OF WHETHER TEKTRONIX OR THE VENDOR HAS ADVANCE NOTICE OF THE POSSIBILITY OF SUCH DAMAGES.**



# Table of Contents

<b>General Safety Summary</b> .....	<b>v</b>
<b>Preface</b> .....	<b>vii</b>
Contacting Tektronix .....	vii
Service Programs .....	vii

## User Information

<b>Getting Started</b> .....	<b>1-1</b>
Unpacking .....	1-2
Standard Accessories .....	1-2
Options .....	1-3
Installation .....	1-4
First Time Operation .....	1-4
<b>Operating Basics</b> .....	<b>1-7</b>
Front Panel .....	1-7
Entering Numerical Values .....	1-10
Automatic Power Control .....	1-11
Rear Panel .....	1-12
<b>Reference</b> .....	<b>1-15</b>
Advanced Functions .....	1-15
Auxiliary Inputs and Outputs .....	1-18
Remote Control .....	1-21
RS-232-C Remote Control .....	1-21
IEEE-488.1 Remote Control .....	1-27
Errors .....	1-32
<b>Specifications</b> .....	<b>1-37</b>

## Service Information

<b>Performance Verification</b> .....	<b>2-1</b>
Equipment Required .....	2-1
Preparation .....	2-2
Absolute Wavelength Accuracy .....	2-3
Wavelength Range and Output Power .....	2-4
<b>Maintenance</b> .....	<b>2-17</b>
Cleaning and Caring for Optical Connectors and Fibers .....	2-17
Calibration .....	2-18
Replacing the Line Fuse .....	2-19
Cleaning the Exterior .....	2-19
Packaging for Shipment .....	2-20
<b>Replaceable Parts</b> .....	<b>2-21</b>

## Appendices

<b>Appendix A: Parameters</b> .....	<b>A-1</b>
<b>Appendix B: Error Messages</b> .....	<b>B-1</b>
<b>Appendix C: RS-232-C Control Commands</b> .....	<b>C-1</b>
Space Characters .....	C-2
Message Termination .....	C-2
<b>Appendix D: IEEE-488.1 Control Command Summary</b> .....	<b>D-1</b>

## Index

# List of Figures

<b>Figure 1–1: Front panel</b> .....	<b>1–7</b>
<b>Figure 1–2: Rear panel</b> .....	<b>1–12</b>
<b>Figure 1–3: Auxiliary connectors</b> .....	<b>1–18</b>
<b>Figure 1–4: Remote interlock connector</b> .....	<b>1–19</b>
<b>Figure 2–1: Accessing the line fuse</b> .....	<b>2–19</b>
<b>Figure 2–2: Replaceable parts</b> .....	<b>2–21</b>
<b>Figure 2–3: Standard accessories</b> .....	<b>2–22</b>
<b>Figure 2–4: Optional power cords</b> .....	<b>2–22</b>

## List of Tables

<b>Table 1–1: Description of Display, Mode, and Setup keys</b> .....	<b>1–8</b>
<b>Table 1–2: Voltage scaling of monitor outputs</b> .....	<b>1–18</b>
<b>Table 1–3: Range of frequencies for modulating the optical power</b> .	<b>1–20</b>
<b>Table 1–4: Example of dialog between the controller and the tunable laser (RS-232-C)</b> .....	<b>1–22</b>
<b>Table 1–5: Examples of message formats with numerics (RS-232-C)</b>	<b>1–24</b>
<b>Table 1–6: Command parameters (RS-232-C)</b> .....	<b>1–24</b>
<b>Table 1–7: Command responses (RS-232-C)</b> .....	<b>1–25</b>
<b>Table 1–8: Operating mode commands (RS-232-C)</b> .....	<b>1–25</b>
<b>Table 1–9: System parameters (RS-232-C)</b> .....	<b>1–26</b>
<b>Table 1–10: Other system commands (RS-232-C)</b> .....	<b>1–27</b>
<b>Table 1–11: Definition of operating commands (GPIB)</b> .....	<b>1–28</b>
<b>Table 1–12: Command parameters (GPIB)</b> .....	<b>1–29</b>
<b>Table 1–13: Queries (GPIB)</b> .....	<b>1–30</b>
<b>Table 1–14: Operating mode commands (GPIB)</b> .....	<b>1–30</b>
<b>Table 1–15: Bits in status word (GPIB)</b> .....	<b>1–32</b>
<b>Table 1–16: Specifications</b> .....	<b>1–37</b>
<b>Table 1–17: Laser class specifications</b> .....	<b>1–38</b>
<b>Table 1–18: Certifications and compliances</b> .....	<b>1–39</b>
<b>Table 2–1: Test equipment</b> .....	<b>2–1</b>
<b>Table 2–2: Wavelength range</b> .....	<b>2–4</b>
<b>Table A–1: Valid range of parameter settings</b> .....	<b>A–1</b>
<b>Table B–1: Error Messages</b> .....	<b>B–1</b>
<b>Table C–1: Summary of RS-232-C control commands</b> .....	<b>C–1</b>
<b>Table D–1: Summary of IEEE-488.1 control commands</b> .....	<b>D–1</b>
<b>Table D–2: Status word</b> .....	<b>D–2</b>



# General Safety Summary

Review the following safety precautions to avoid injury and prevent damage to this product or any products connected to it. To avoid potential hazards, use this product only as specified.

*Only qualified personnel should perform service procedures.*

## To Avoid Fire or Personal Injury

**Use Proper Power Cord.** Use only the power cord specified for this product and certified for the country of use.

**Ground the Product.** This product is grounded through the grounding conductor of the power cord. To avoid electric shock, the grounding conductor must be connected to earth ground. Before making connections to the input or output terminals of the product, ensure that the product is properly grounded.

**Observe All Terminal Ratings.** To avoid fire or shock hazard, observe all ratings and markings on the product. Consult the product manual for further ratings information before making connections to the product.

Do not apply a potential to any terminal, including the common terminal, that exceeds the maximum rating of that terminal.

**Do Not Operate Without Covers.** Do not operate this product with covers or panels removed.

**Use Proper Fuse.** Use only the fuse type and rating specified for this product.

**Avoid Exposed Circuitry.** Do not touch exposed connections and components when power is present.

**Wear Eye Protection.** Wear eye protection if exposure to high-intensity rays or laser radiation exists.

**Do Not Operate With Suspected Failures.** If you suspect there is damage to this product, have it inspected by qualified service personnel.

**Do Not Operate in Wet/Damp Conditions.**

**Do Not Operate in an Explosive Atmosphere.**

**Keep Product Surfaces Clean and Dry.**

**Provide Proper Ventilation.** Refer to the manual's installation instructions for details on installing the product so it has proper ventilation.

### Symbols and Terms

**Terms in this Manual.** These terms may appear in this manual:



---

**WARNING.** Warning statements identify conditions or practices that could result in injury or loss of life.

---



---

**CAUTION.** Caution statements identify conditions or practices that could result in damage to this product or other property.

---

**Terms on the Product.** These terms may appear on the product:

**DANGER** indicates an injury hazard immediately accessible as you read the marking.

**WARNING** indicates an injury hazard not immediately accessible as you read the marking.

**CAUTION** indicates a hazard to property including the product.

**Symbols on the Product.** The following symbols may appear on the product:

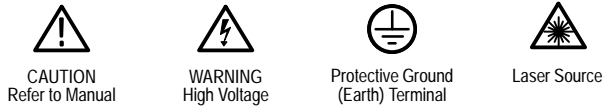

WARNING  
Laser Class 3A and Class IIIb

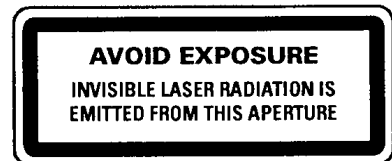

WARNING  
Laser Class 3A and Class IIIb

# Preface

This manual provides the user information necessary to operate, program, and verify the performance of the LPB 1300 and LPB 1550 Tunable Laser Sources. The manual also contains maintenance procedures that the user can perform from outside the instrument and information about user serviceable parts.

Components inside the instrument are not user serviceable. Refer all servicing of internal components to service personnel authorized by Tektronix.

## Contacting Tektronix

Product Support	For application-oriented questions about a Tektronix measurement product, call toll free in North America: 1-800-TEK-WIDE (1-800-835-9433 ext. 2400) 6:00 a.m. – 5:00 p.m. Pacific time  Or contact us by e-mail: tm_app_supp@tektronix.com  For product support outside of North America, contact your local Tektronix distributor or sales office.
Service Support	Contact your local Tektronix distributor or sales office. Or visit our web site for a listing of worldwide service locations.  www.tektronix.com
For other information	In North America: 1-800-TEK-WIDE (1-800-835-9433) An operator will direct your call.
To write us	Tektronix, Inc. P.O. Box 1000 Wilsonville, OR 97070-1000

## Service Programs

Tektronix offers extended warranty and calibration coverage programs that you can purchase as options with the product. These programs are cost-effective ways to maintain genuine Tektronix service for your instrument. Ask your Tektronix distributor or sales office for details.





# User Information



# Getting Started

The LPB 1300 and LPB 1550 Tunable Laser Sources are compact, bench-top instruments for the development and test of fiber-optic systems and components. The flexible, general-purpose design is suitable for a wide range of applications.

The optical layout uses a modified Littman-Metcalf configuration. The double-pass reflection on the grating provides maximum dispersion while the very short cavity maximizes mode-spacing. This design avoids mode competition and guarantees spectrally pure, single-mode operation. The high-performance optical isolator and the angle-polished fiber on the output work to protect the laser cavity from interference and ensure optimum power and spectral purity. A dihedral reflector in the rear of the laser cavity acts as a two-dimensional corner cube to keep the resonator in tune.

The LPB 1300 and LPB 1550 Tunable Laser Sources offer the following benefits:

- Precise wavelength tuning. Provides a 1 pm resolution.
- Digitally-controlled analog fine tuning. Extends resolution beyond the 1 pm steps into the MHz domain.
- Mode hop-free operation. Ensures smooth and accurate wavelength sweep for reliable testing of narrow band components (mode hop spacing > 70 nm on the LPB 1550 laser and > 40 nm on the LPB 1300 laser).
- High output power. Delivers the rated output power over the entire wavelength range: 0 dBm (standard), 6 dBm (Option P6), or 10 dBm (Option PX, LPB 1550 only).
- Outstanding long-term stability. Keeps the resonator in tune with a self-aligning optical layout, reliable design, and thermally stable construction. Prevents small changes caused by shock, vibration, temperature, or mechanical drift from affecting operation.
- Intuitive, user-friendly controls. Simplifies operation with easy-to-use keypad or multi-speed rotary control.
- Modulation possibilities. Analog and digital modulation of the optical power from DC to 1 GHz with mode-locked operation at 5 GHz. The 150 kHz linewidth can go to 100 MHz when high coherence is a problem.
- Remote operation and easy system integration. Provides IEEE-488.1 and RS-232-C computer interfaces, modulation inputs, and monitor outputs.

## Unpacking

Handle the instrument carefully when unpacking. Keep the instrument in a lateral position at all times.



---

**CAUTION.** *This instrument contains delicate optical components. To avoid misalignment of the optical components, use both handles on the sides of the instrument and keep the instrument in a lateral position during unpacking and handling.*

*Do not set the instrument on the rear bumpers. These bumpers are only for purposes of protecting the rear panel from contact with adjacent surfaces and should not be used as feet when transporting or storing the instrument.*

---

After unpacking, set the instrument on a stable surface that is free of excessive vibration.

## Standard Accessories

The following accessories are standard with the LPB 1300 and LPB 1550 Tunable Laser Sources:

- Certificate of traceable calibration
- Calibration data (Option D1 test report)
- FC/PC-to-FC/APC adapter cable
- Safety lock key
- Instruction manual
- Power Cord

For a list of replaceable part numbers, see the *Replaceable Parts* section that begins on page 2–21.



## Options

The following options are available at the time of purchase:

- Option A1, A2, or A3 Power Cord, see Figure 2–4 on page 2–22
- Option C3 Three years calibration service
- Option D3 Three years calibration data
- Option 1L Labview driver
- Option P6 6 dBm output power (LPB 1550 only)
- Option R3 Three years extended warranty
- Option PX 10 dBm output power (LPB 1550 only)
- Option 1M Polarization maintaining fiber and adapter cable (blue)
- Option 1W Modified wavelength range
- Option 2W Modified wavelength range (LPB 1550 only)
- Option 3W Modified wavelength range (LPB 1550 only)

---

**NOTE.** *The range of each wavelength (W) option varies according to the model and power (P) option. See the Specifications section on page 1–37 for details.*

---

## Installation

Install the LPB 1300 and LPB 1550 Tunable Laser Sources as follows:

1. Use the proper power cord for your location.
2. Keeping the instrument in a lateral position, transport the instrument using the handles on both sides.
3. Place the instrument on a stable surface that is free of excessive vibration.
4. Make sure the keyed switch on the front panel is in the standby mode before applying power.
5. Allow air for the cooling fan to flow freely around the instrument; move any equipment or papers that could impede air flow.

## First Time Operation



---

**WARNING.** To avoid eye damage, do not look into the laser output or into the end of an optical cable. Even though the laser radiation is not visible, the intense infrared light can still cause eye damage.

*Always disable laser output while connecting and disconnecting the optical fiber.*

---

### Cleaning the Optical Connections

For the best performance, optical connections must be clean and free of contamination. Cleaning instructions for optical connections are on page 2–17.

### Connecting the Laser Output

To connect the laser output, remove the protective cap and use a fiber with a FC/APC type connector.



---

**CAUTION.** To avoid damage to the laser output, always use a FC/APC type connector. To connect other styles, use the FC/PC to FC/APC jumper.

*To help protect the laser output, leave a jumper cable in place when making connections to other devices. When the laser output is not connected, the protective cover should be over the laser output.*

---

## Initializing the Laser

For safe operation, use the following procedure to initialize the laser:

1. Make sure the key on the front panel is in the Standby position.
2. Connect line cord to the socket on the rear panel and then to the proper mains supply.
3. Set the rear panel MAINS switch to on ( I ). See Figure 1–2 on page 1–12.
4. Turn the front panel POWER key to the right (ON). During the initialization phase, the message “Initializing...” displays. This message clears once the laser is initialized and ready for operation.

At the end of the initialization, the message “Disabled...” appears on the display signifying that the laser output is ready to enable.



---

**CAUTION.** Avoid switching the laser off before the laser is fully initialized.

---

After initialization, the cavity tunes to a wavelength near the center of the wavelength range.

The optical power setting initializes to zero when the laser is enabled.

## Enabling the Output

For safety reasons, the laser provides an Enable button to enable or disable the output.

- To enable the laser output, press the Enable button. The Enable key lights.
- To disable the laser output, press the Enable button and check that the Enable light is out.

## Shutting Down the Laser

To shut down the laser, turn the front panel key left to the standby position. The message “Parking...” displays and the optical head automatically moves to the parking position. After a few seconds, the laser shuts down by itself.



---

**CAUTION.** Avoid switching the power to standby before the laser is fully initialized. After turning the power to standby, wait at least thirty seconds before initializing the laser again.

---



# Operating Basics

This section provides an overview of the controls, connectors, and functions of the LPB 1300 and LPB 1550 Tunable Laser Sources.

## Front Panel

Figure 1–1 shows the front panel features.

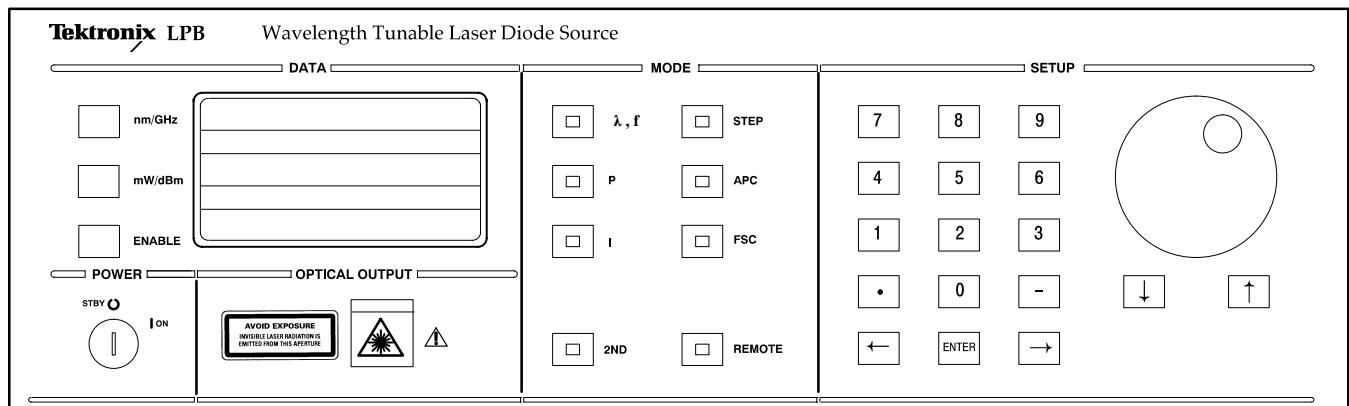

Figure 1–1: Front panel

The front panel is divided into five areas:

- Power
- Data
- Mode
- Setup
- Optical Output

**Power** After switching on the mains switch (rear panel), the power switch initializes the laser head in the ON position or parks the laser head in the STBY (standby) position. When the message “Disabled...” appears, the laser is ready to enable by using the ENABLE key located in the data area.



**CAUTION.** Avoid switching the power to standby before the tunable laser is fully initialized. After turning the power to standby, wait at least thirty seconds before initializing the laser again.

### Data, Mode, and Setup

The Data area displays wavelength or frequency ( $\lambda$ ,  $f$ ) and the output power (mW/dBm) as selected by the data keys. The instrument also uses this area to display messages.

Mode keys select instrument functions and work with keys in the Setup area to enter numerical values, access advanced functions, and set scan steps.

Table 1–1 lists the display and mode keys along with a description of the function they perform. For more instructions, see the section *Entering Numerical Values* on page 1–10.

**Table 1–1: Description of Display, Mode, and Setup keys**

Name	Description
nm/GHz	Displays the wavelength in nm or the optical frequency in GHz.
mW/dBm	Displays the power in dBm or mW.
$\lambda$ , $f$	Enables entry of a new value for the wavelength.
P	Enables entry of a new value for the power output and switches to the constant power mode.
I	Enables entry of a new value for the diode current and switches to the constant current mode.
ENABLE	Enables/Disables the optical output. When disabled, the message "Disabled..." is displayed. When enabled, the Enable light is on.
REMOTE	Enables front panel (local) operation. The Remote button has no effect when the light is off during local operation.  The Remote key lights and Remote operation begins when the laser receives data on either the RS-232-C or the IEEE-488.1 interface.
FSC	(Fine Scanning mode.) Enables a quasi-continuous sweep of the wavelength on a $\pm 2$ GHz range. Once this mode is selected, the wavelength can be continuously adjusted with the rotating knob. The wavelength sweep is displayed in GHz. To exit the fine scanning mode, press the FSC key again.
APC	(Automatic Power Control.) Switches between constant current (APC light off) and constant power (APC light on) modes. See <i>Automatic Power Control</i> on page 1–11.
← or →	Increases or decreases the wavelength by the value of the STEP parameter. Backspaces or forward spaces to correct numbers during keypad entry.

**Table 1-1: Description of Display, Mode, and Setup keys (Cont.)**

Name	Description
↓ or ↑	Decreases or increases the elementary step of the control knob. The message, "Scroll..." indicates which digit relative to the decimal point the control knob changes.
ENTER	Enters the numerical value.
STEP	Changes the STEP parameter.
2ND	Accesses advanced functions.
2ND > λ,f	Initiates wavelength calibration.
2ND > P	Initiates power calibration.
2ND > STEP	Enables wavelength scan mode.
2ND > 1	Disables/Enables backlash suppression of the micrometer screw.
2ND > 2	Displays software release.
2ND > REMOTE	Changes GPIB address.
2ND > FSC	Enables linewidth coherence control.

**Optical Output**

The Optical Output area includes the angle polished connector (APC) output with protective cover. The ENABLE key that enables and disables the optical output is located in the data area.

## Entering Numerical Values

Using the basic procedure in this section, you can use the keypad or control knob to edit the parameters for the following functions:

- Emission wavelength ( $\lambda$ , f)
- Optical power (P)
- Diode Current (I)
- Wavelength step (STEP)

Information on editing the parameters for other functions begins on page 1–15.

### Basic Procedure

Use the keypad or control knob to enter numerical values as follows:

1. Press the appropriate key function ( $\lambda$ , f, I, or P).
  - a. The related indicator lights and the display shows the present setting for the chosen parameter.
  - b. The equal sign (=) on the display blinks to show that this parameter can be changed.
2. Change the present setting with the keypad or the control knob.
  - a. To correct a number during entry, back space or forward space using the  $\leftarrow$  or  $\rightarrow$  keys.
  - b. To exit the edit mode without saving the new value, press the same parameter key ( $\lambda$ , f, I, or P) as the function.
3. If you are using the keypad, press the ENTER key to enter the new value. If you are using the control knob, the value is updated in real time.
4. If the value is outside the range of acceptable settings, the message “Lim” displays and the setting remains the same.

For instance, to enter a power of 0.5 mW, key in the following sequence:

P	Parameter selection
0.5	New value (.5 is also valid)
ENTER	Validation of the new value



---

**NOTE.** *If the new value is outside the valid range for the parameter, an error message displays (“Value error Press ENTER”). Pressing ENTER retains the former setting and suspends scanning or calibration.*

*For a listing of the valid ranges for each system parameter, refer to Appendix A on page A-1.*

---

### Arrow Keys

The ← and → keys decrease or increase the wavelength by the step value. To change the step value, press STEP and use the control knob or keypad to enter the new value (STEP > new value in nm > ENTER). The keys also allow you to forward or backspace during keypad entry.

The ↓ and ↑ keys below the control knob decrease or increase the elementary step of the control knob. In the message “Scroll 0.01,” for example, the 1 indicates which digit in relation to the decimal point the control knob changes. To select a different digit, press either arrow key repeatedly until the 1 is in the same place as the digit you wish to change, and then turn the control knob.

### Backlash Suppression

When using the keypad or the ← and → arrow keys to set the wavelength value, the software of the tunable laser suppresses the mechanical backlash of the tuning mechanism.

When using the control knob to change the wavelength value, the value changes in real time and the backlash suppression is not active. A dot (“.”) at the right end of the wavelength display indicates the absence of backlash suppression.

Example : “ $\lambda=1555.000$  nm .”

The backlash suppression procedure activates the next time you use the keypad or the ← and → arrow keys to enter a value.

## Automatic Power Control

The Automatic Power Control (APC) button on the front panel switches between constant current and constant power modes. In the constant current mode, the APC light is off and the I parameter indicates the diode current. When the APC light is on, the diode current is controlled to deliver optical power equal to the P parameter.

---

**NOTE.** In some cases, it may not be possible to reach the required power even with the maximum allowable current. When this happens, the current limits at the maximum value and the message “Lim” appears at the right end of the displayed power.

---

(Example : P = 5.4 mW Lim )

## Rear Panel

Figure 1–2 shows the rear panel of the LPB 1300 and LPB 1550 Tunable Laser Sources.

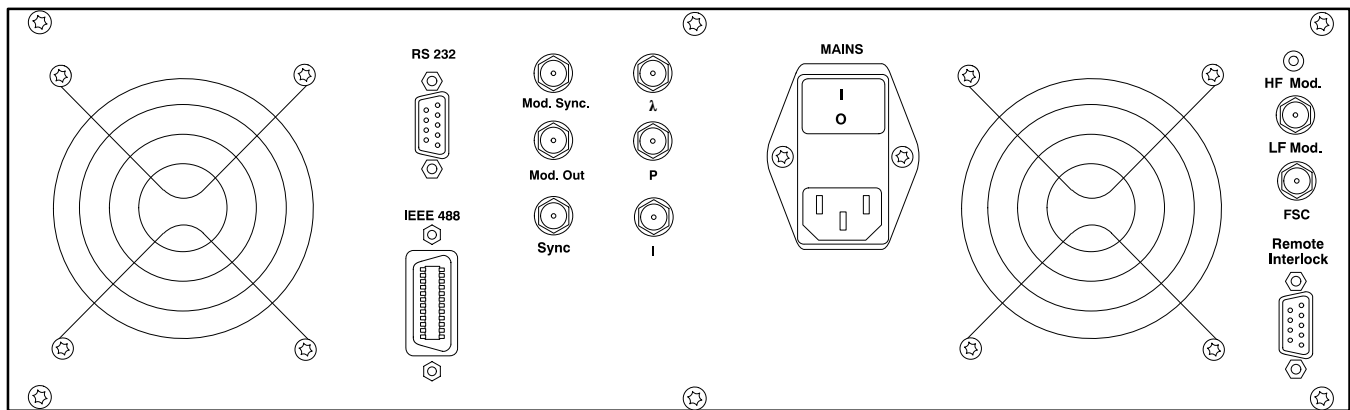

Figure 1–2: Rear panel

The MAINS module includes the mains power switch, power cord connection, and fuse drawer.

In addition to the MAINS module and two remote control connectors (RS-232-C and IEEE-488.1), ten auxiliary IN/OUT connectors are available on the rear panel:

Analog and TTL outputs:

- Mod. Sync. (modulation sync) TTL output
- Mod. Out (modulation output) TTL output

Monitor (scaled) outputs:

- Sync (motor sync)
- $\lambda$  (wavelength)

- P (power)

- I (current)

Inputs:

- FSC (fine scanning and coherence control)

- HF Mod (high frequency modulation)

- LF Mod (low frequency modulation)

- Remote interlock connection as required by Class IIIb.

For a discussion of these connectors, see *Auxiliary Inputs and Outputs* on page 1–18.



# Reference

This section describes the advanced functions, RS-232-C and IEEE-488.1 interfaces, and auxiliary inputs and outputs of the LPB 1300 and LPB 1550 Tunable Laser Sources.

## Advanced Functions

Press the 2ND key on the front panel (which functions like a shift key) to access the following functions:

- Wavelength scanning
- Wavelength calibration
- Power calibration
- Backlash suppression of the micrometer screw
- Changing the GPIB address

### Wavelength Scanning

Wavelength scanning presets the tunable laser to emit a range of different wavelengths for selected intervals of time.

1. To activate the scan mode, press 2ND > STEP.

The tunable laser requests the first of the following scan parameters:

- The first scan wavelength
  - The last scan wavelength
  - The scan increment
  - The pause time between two steps
2. To progress through the scan parameters, you must confirm or modify each parameter in order:
    - a. To modify a parameter, press the numeric keys followed by the ENTER key.
    - b. To keep a parameter, press the ENTER key without entering a new value.
    - c. To cancel the entire scan procedure and retain the previous parameters, press the STEP key a second time before entering the value.

After you enter the last parameter, the tunable laser goes to the first wavelength. The wavelength increments step by step (applying the scan step parameter value) until the tunable laser reaches the last wavelength. At each step the wavelength remains constant during the pause time parameter.

3. To suspend scanning, press the STEP key during wavelength scanning. The message: “Stop scan (1/0) ?” asks the operator to confirm termination of the scan.
  - a. To stop scanning, press 1, scanning stops and the emission wavelength remains at the displayed value.
  - b. To resume scanning, press 0.

For all modes except the remote mode, the tunable laser goes back to the first wavelength and scanning repeats indefinitely after reaching the upper wavelength.

In the remote mode, scanning ends when the tunable laser reaches the upper wavelength.

## Wavelength Calibration

The wavelength calibration procedure calibrates the wavelength setting of the laser output. The procedure requires the use of an optical wavemeter.



---

**CAUTION.** *This procedure erases factory calibration data for the optical wavelength settings. Do not use this procedure unless you intend to erase this data.*

---

1. Connect the output of the tunable laser to a wavemeter.
2. Press the 2ND key followed by the  $\lambda$  key to initiate wavelength calibration.

The tunable laser moves to a short wavelength of the tuning range and displays the default value corresponding to the calibration data.

3. Measure the first wavelength with the wavemeter.
4. Enter the reading after the display prompt ( $\lambda =$  ).

The tunable laser moves to a long wavelength of the tuning range, and displays the default value corresponding to the actual calibration data.

5. Measure the second wavelength with the wavemeter.
6. Enter the reading after the display prompt ( $\lambda =$  ).

The wavelength calibration is now complete and all wavelength settings are referenced to the new data.

## Power Calibration

The power calibration procedure calibrates the laser output power. The procedure requires the use of an optical power meter.



---

**CAUTION.** *This procedure erases factory calibration data for optical power. Do not use this procedure unless you intend to erase this data.*

---

1. Connect the output of the tunable laser to a power meter.
2. Press the 2ND key followed by the P key to initiate power calibration.
3. The tunable laser moves to a short wavelength of the tuning range and displays the power level corresponding to the calibration data.
4. Measure the power level at the first wavelength.
5. Enter the reading after the display prompt (P = ).
6. The tunable laser moves to a long wavelength of the tuning range, and displays the power level corresponding to the actual calibration data.
7. Measure the power level at the second wavelength.
8. Enter the reading after the display prompt (P = ).

The power calibration is now complete and all power settings are referenced to the new data.

## Backlash Suppression of the Micrometer Screw

The software of the tunable laser uses a procedure to eliminate the effect of the backlash of the tuning micrometer screw.

1. To cancel backlash suppression, press 2ND > 1.

A dot “.” at the right end of the wavelength display indicates backlash suppression is inactive.

Example : “ $\lambda=1555.000$  nm .”

2. To reactivate backlash suppression, press 2ND > 1 again.

## Changing the GPIB Address

By default, the GPIB address of the tunable laser is 10.

To change the default address, press 2ND > REMOTE. The tunable laser displays the actual address and prompts for the new value.

## Auxiliary Inputs and Outputs

Figure 1–3 shows the auxiliary input and output connectors on the rear panel.

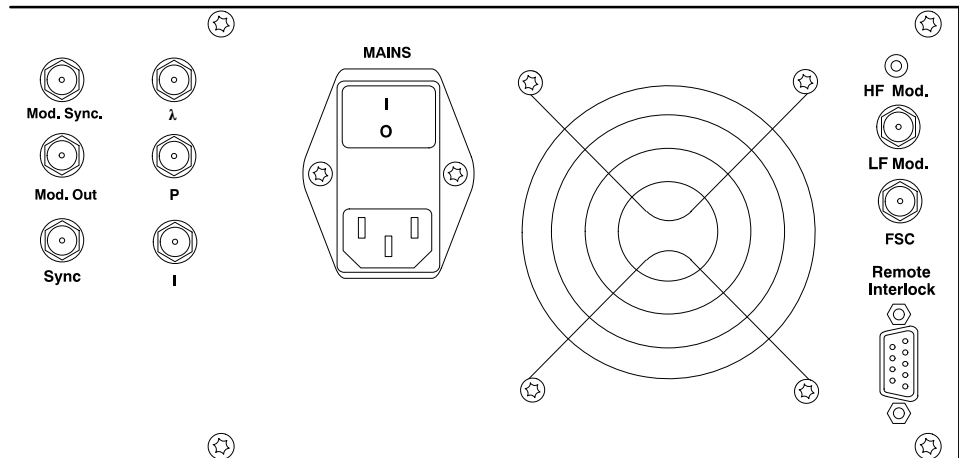

Figure 1–3: Auxiliary connectors

### Monitor Outputs

The outputs that allow continuous monitoring of the tunable laser are  $\lambda$  (wavelength), P (power), I (current), and Sync (motor). The scaling of the signal voltage at these outputs is as follows:

Table 1–2: Voltage scaling of monitor outputs

Name	Voltage scaling
$\lambda$	66.66 mV/nm, typical
P	0.3 mV/ $\mu$ W, typical
I	20 mV/mA , typical 0 V corresponds to 1400 nm (LPB 1550) or 1200 nm (LPB 1300)
Sync	0 V: motor moving 5 V: motor not moving
Mod. Out	Modulation output (TTL)
Mod. Sync	Modulation synchronization (TTL, same signal as Mod. Out)



---

**NOTE.** To minimize noise levels on the diode control and on the monitor output circuits, the BNC connectors for the monitor outputs are isolated from chassis common and earth ground. To prevent increasing the noise levels, connect the monitor outputs to devices with differential inputs that are also isolated from ground. Otherwise, the tunable laser optical output may have higher than normal power fluctuations.

---

## Remote Interlock

Figure 1–4 show the pin out of the Sub-D9 connector on the rear panel labeled Remote Interlock. The remote interlock connector is a safety feature required by the Laser Class IIIb standard.

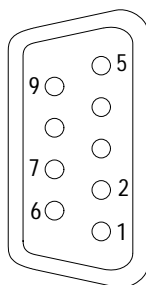

**Figure 1–4: Remote interlock connector**

To use the interlock feature, the user must supply a mating connector that shorts pins 1 and 2 and connects a normally open safety switch between pins 6 and 7. The switch must be electrically isolated from all other circuits including earth ground. The switch disables the laser output when open.

Without any connections to the interlock, normal operation of the tunable laser is unaffected.

## Wavelength Fine Tuning and Coherence Control

On the front panel, the tunable laser has a wavelength fine tuning function (FSC) and a coherence control function (2nd > FSC). The fine tuning function enables the control knob to precisely adjust the wavelength or optical frequency. The coherence control function broadens the linewidth.

On the rear panel, the wavelength fine tuning and coherence control functions are available through the FSC connector. When a voltage is applied to this connector, the optical frequency shifts by 200 MHz per applied volt on the LPB 1300 and by 300 MHz per applied volt on the LPB 1550. The maximum input voltage is  $\pm 10$  volts. This input also allows wavelength modulation, by applying a modulation signal whose frequency is lower than 1 kHz.

If a noise signal is directly injected in the FSC input to modulate the optical frequency, it will induce an apparent broadening of the linewidth of the laser leading to a reduction of the coherence length. One application of this technique is to wash out parasitic interference in the user setup.

## Optical Power Modulation

The LF Mod (BNC) and HF Mod (SMA) inputs are connected to the laser diode and allow the user to add an external current to the bias current of the diode. By modulating this extra current, it is possible to modulate the optical power output as shown in Table 1–3.

**Table 1–3: Range of frequencies for modulating the optical power**

Input Connector	APC	Frequency range
LF Mod (BNC connector)	Off	DC to 8 MHz
	On	10 kHz to 8 MHz
HF Mod (SMA connector)	On or off	30 kHz to 1 GHz

In the APC mode, the tunable laser monitors the average power of the optical output and constantly adjusts the bias current so that the output power is constant. If a DC or low-frequency signal below 1 kHz is applied to the LF Mod input, it will have no effect on the output power. However, if the frequency of the signal applied to the LF Mod input is well above 1 kHz, the output signal will modulate around an average power determined by the settings of the tunable laser. For this reason, the modulation frequency should be above 10 kHz.



**CAUTION.** To avoid damaging the laser diode, do not over drive the modulation input. See the conditions that follow.

The Mod inputs are directly connected to the laser diode chip, so the user must ensure that the input voltage ( $|V|_{\max}$ ) meets the following two conditions:

1. The diode laser is forward biased.  
 $|V|_{\max} < 50 \times I_{\text{bias}}$
2. The current flowing through the diode is lower than the maximum admissible current ( $I_{\max}$ ) indicated in the acceptance test report.  
 $|V|_{\max} < 50 \times (I_{\max} - I_{\text{bias}})$

The best way to determine the system bias current is to measure the voltage on the current monitor output. The voltage scaling on the current monitor output is 20 mV/mA.

The maximum and minimum values of  $V_{in}$  should be chosen so that the total current ( $I_t$ ) remains positive and lower than the maximum admissible current ( $I_{max}$ ):

$$0 < I_t < I_{max}$$

The Mod Out (modulation out) and Mod Sync (modulation sync) connectors provide identical 31.2 kHz TTL signals. The Mod out signal can be used to drive the LF Mod input and the sync signal is available to synchronize another piece of test equipment.

## Remote Control

When the tunable laser receives data from the RS-232-C or the IEEE-488.1 interfaces, it enters the remote mode and the indicator light on the REMOTE key switches ON.

- When the tunable laser is operating in the remote mode, all keys are disabled except the REMOTE key.
- To exit the remote mode, press the REMOTE key.

---

**NOTE.** If the tunable laser receives a message through the serial interface ending with a return character ( $\rceil$ ), the remote mode automatically activates even if the message itself is invalid.

---

## RS-232-C Remote Control

The tunable laser is in the remote mode when the REMOTE key light is on. The remote mode disables all the keyboard keys and allows the tunable laser to receive commands through the RS-232-C interface. Additional specific commands are also available using this interface.

### Physical Interface

The cable link is a three-wire RS-232-C type using a SUB-D9 plug. The serial port is configured in the terminal mode: data sent to the serial port is on pin 2 of the connector and return messages are on pin 3. The ground is through pin 5. No other connector pin is used.

The serial port is configured as follows:

Data transmission rate	9600 baud
Number of bits	8
Parity	no
Stop bits	1

**Message Format** All commands sent by the computer to the tunable laser are composed of a string of ASCII alphanumeric characters followed by a return (ASCII code 13). When such an instruction is received, the character string is decoded and the relevant procedure is carried out.

After completion, a message informs the computer that the requested procedure has been performed or that an error situation has been encountered. This response message is always terminated by the same group of three characters:

return character (↵)

greater than character (>)

space character ( )

These three characters indicate that the tunable laser is ready to receive a new instruction. Table 1-4 gives an example of dialog between the computer and the tunable laser.

**Table 1-4: Example of dialog between the controller and the tunable laser (RS-232-C)**

Message to tunable laser	Meaning	Response from tunable laser	Meaning
APCON↵	Set constant power (APC) on	OK↵ >	Instruction performed The tunable laser is ready to receive another instruction
I=160	Change diode current to 160 mA	Value error↵ >	Current level is over permitted maximum The tunable laser is ready to receive another instruction
L?↵	What is the actual wavelength value?	L = 1523.325↵ >	Actual wavelength value is 1523.325 nm The tunable laser is ready to receive another instruction

The message syntax described above eases the management of the interface since the computer must await the acknowledgment before sending a new instruction. To easily detect the end of the message, the response from the tunable laser is always terminated by the same three characters.

Other considerations include the following:

- The tunable laser does not distinguish between lower and upper case alphabetical characters.
- It is possible to send a series of instructions in a single string: successive instructions should be separated by a semicolon (;), and the string should end

with a return character ( $\downarrow$ ). The different instructions will be analyzed as soon as the  $\downarrow$  character is received and will be executed in sequence.

- The input buffer length is 255 characters; if more than 255 characters are sent in a single string, or before previous strings have been analyzed, the buffer will be cleared, all received instructions lost, and the message “command error” sent.
- Space characters are allowed in some places inside the strings: they can be placed at the beginning of an instruction; after an instruction; or before, after, or in place of the equal sign (=). They cannot be inserted within an instruction mnemonic, within a numeric, or between a mnemonic and the question mark (?).
- On the RS-232-C interface, all characters with ASCII codes lower than or equal to 32, except the return character (ASCII code 13) are considered as space characters.

## Response Messages

All instructions requesting a parameter reset or a change of operating mode give rise to an “OK” acknowledgment (terminated by  $\downarrow$ ,  $>$ , and a space) from the tunable laser when the command has correctly executed. The only exception to this general rule is the SCAN command, since the acknowledgment in this case is “Scanning...” which is sent as soon as scanning has begun, followed by “End of scan” when scanning has terminated.

If a command is not recognized, the message returned is “Command error”. If a command requesting a new parameter setting is correctly formulated but the specified value is outside the allowed limits for that parameter, the setting will remain unchanged and the response is “Value error”.

## Format of Numerics

Some command messages include a numeric. The format rules are as follows:

- No spaces are allowed within the numeric.
- Leading zero (0) characters are allowed at the beginning of a numeric.
- After the decimal point, trailing zero (0) characters may be included or omitted.
- Either a period (.) or comma (,) character designates the decimal point.
- The return character ( $\downarrow$ ) terminates the numeric. No unit abbreviations are allowed after the numeric.

Table 1–5 gives some correct and incorrect examples of the message formats that include numerics.

**Table 1–5: Examples of message formats with numerics (RS-232-C)**

Entry	Correct/Incorrect	Meaning
P=0.22	Correct	Set power to 0.22 mW
L=1530.2	Correct	Set wavelength to 1530.200 nm
P=01	Correct	Set power to 1 mW
I= 25	Correct, spaces are before the numeric	Set diode current to 25 mA
I=25 mA	Incorrect, unit abbreviations not allowed	Command error
Smin=1 520.31	Incorrect, space between "1" and "5" not allowed	Command error

## Changing Parameter Settings

Table 1–6 lists the commands for each parameter setting of the tunable laser. Each “n” represents an integer from 0 to 9. All commands must be terminated by the return character.

**Table 1–6: Command parameters (RS-232-C)**

Command	Action
I=nn.n	Sets the laser current level (mA) and switches to the constant current mode.
P=nn.nn	Sets the the optical power (mW). See MW in Table 1–8.
P=±n.nn	Sets the the optical power (dBm). See DBM in Table 1–8.
L=nnnn.nnn	Sets the wavelength (nm). The “OK” acknowledgment is sent when the emission wavelength is stabilized.
f=nnnnnn.n	Sets the optical frequency (GHz). The “OK” acknowledgment is sent when the emission wavelength is stabilized.
FSCl=nn.n	Switches to the Fine Scanning mode. The numeric nn.n is the change in wavelength (pm). (Also available with the fine scanning option.)
FSCF=n.nn	Switches to the Fine Scanning mode. The numeric n.nn is the change in optical frequency (GHz). (Also available with the fine scanning option.)
Smin=nnnn.nnn	Sets the lower limit scanning wavelength (in nm).
Smax=nnnn.nnn	Sets the upper limit scanning wavelength (in nm).
Step=n.nnn	Sets the wavelength scan step (in nm).
Stime=nn.n	Sets the stop time (in seconds) between each scan step.
LCAL1=nnnn.nnn	Defines the first calibration wavelength.

Table 1–6: Command parameters (RS-232-C) (Cont.)

Command	Action
LCAL2=nnnn.nnn	Defines the second calibration wavelength.
PCAL1=nn.nn	Defines the calibration power (first wavelength),
PCAL2=nn.nn	Defines the calibration power (second wavelength).
B_SUPPR=1	Enables backlash suppression irrespective of the previous state.
B_SUPPR=0	Enables backlash suppression irrespective of the previous state.

Table 1–7 lists the possible command responses from the tunable laser.

Table 1–7: Command responses (RS-232-C)

Response	Meaning
OK	Command executed
Value error	Value outside valid limits
Command error	Syntax error

## Changing the Operating Mode

Table 1–8 lists the commands that change the operating mode.

Table 1–8: Operating mode commands (RS-232-C)

Command	Action
APCON	Switch to constant power mode.
APCOFF	Switch to constant current mode.
SCAN	Initiate wavelength scanning. the laser response message is "Scanning..." when scanning starts, followed by "End of scan" when scanning is terminated.  <i>NOTE: Unlike scanning initiated locally using the laser controller keypad, once the upper wavelength scan limit has been reached, scanning terminates; it does not start again at the lower wavelength scan limit. Each parameter can be altered individually without changing the others and the previous parameters are retained from one scan session to the next.</i>
STOP	Stop scan. When scanning is terminated, the message "End of scan" is sent by the laser.  <i>NOTE: While scan is running, all commands are disabled (this is indicated by the response message "Command error"), with the exception of parameter value requests and the STOP instruction.</i>
DBM	Selects dBm unit for transmission of optical power values to and from the laser, and for displayed values.

**Table 1–8: Operating mode commands (RS-232-C) (Cont.)**

Command	Action
MW	Selects mW unit for displayed values and for transmission of optical power values to and from the laser.
INIT	Initialize the optical head.
ENABLE	Enable the optical output.
DISABLE	Disable the optical output.

### Reading the System Parameters

Table 1–9 lists the queries for system parameters of the tunable laser.

**Table 1–9: System parameters (RS-232-C)**

Query	Action	System response
I?	Request the present current level.	"I=nn.n" (mA) or "disabled" if the Enable mode is not active.
P?	Request the present power output level.	"P=nn.nn" (mW) or "P=+nn.nn" (dBm) or "disabled" if the Enable mode is not active.
L?	Request the present wavelength value.	"L=nnnn.nnn" (nm).
f?	Request the present optical frequency value.	"L=nnnn.nnn" (nm).
LIMIT?	Request the status of the current limit.	The answer is "Yes" if the current is limited and "No" otherwise.
B_SUPPR?	Request the status of the backlash suppression.	The answer is B_SUPPR=1 if the backlash suppression is active and B_SUPPR=0 if it is disabled.



**Other System Commands** Table 1–10 lists the other system commands of the LPB 1300 and LPB 1550 Tunable Laser Sources.

**Table 1–10: Other system commands (RS-232-C)**

Command	Action
ECHON	When this mode is active, the laser sends an echo of each character received back through the serial cable. Since some terminals and terminal emulation programs do not feature local echo, this function can be useful for visual monitoring of the characters keyed in at the terminal.
ECHOFF	<p>Cancels "echo" mode.</p> <p><i>NOTE: The default option is ECHOFF. Specifically, anytime you cancel the remote mode using the REMOTE key then re-activate it, the echo mode switches to ECHOFF.</i></p>

## IEEE-488.1 Remote Control

The General Purpose Interface Bus (GPIB) of the LPB 1300 and LPB 1550 Tunable Laser Sources is compatible with the IEEE-488.1 standard.

The controller sends instructions over the GPIB with one string of ASCII characters for each instruction. These instructions can be either definition instructions for the operation of the tunable laser (for example, "I=35" means "Set the level of the current to 35 mA") or requests of a parameter value (for example, "I?" to ask for the value of the current level). The microprocessor of the tunable laser immediately handles each instruction/request.

The computer must address the tunable laser as the "talker" to read the value transmitted by the tunable laser over the GPIB. For example, if the computer requests the value of the current ("I?") and addresses the tunable laser as "talker," the transmitted response on the bus will be in the form "I=35".

---

*NOTE. To accelerate and secure the exchange of informations between the controller and the tunable laser, use a serial poll command to check the value of the status word. (See Definition of Status Word on page 1–32).*

---

This status word contains the information that allows the controller to know the status of commands received by the tunable laser, and determines when the controller can send a new instruction or read a parameter. In particular, when the controller reads a parameter value, the bit MAV (message available) indicates that the tunable laser has measured the requested parameter and that the answer message is available.

**Protocol of Messages**

The following protocol applies for the transmission and reception of messages:

- Each message sent by the controller to the tunable laser must end either with the line-feed character (LF, ASCII code10), or with the end-of-identify (EOI) message, or with both of them.
- Each message may contain one instruction or more. If more than one instruction is sent, successive instructions should be separated with the semicolon (;) character.
- Numerics must be transmitted in a fixed-decimal-point format for non-integer values (values of the current, for example) and without a decimal point for integer values (the validation byte of the request condition for service of the SRE instruction, for example).
- Space characters can be placed within a message at certain positions; they can be placed before an instruction or at the end of an instruction; or instead of, after, or before the equal (=) sign. It cannot be placed within a mnemonic, nor within a numeric, nor between a mnemonic and the question mark (?) character.
- All alphabetic characters can be either upper or lower case letters.
- The instructions for parameter modification are composed of the name of the parameter, the (=) sign, and the value of the parameter. The parameter-request instructions are composed of the name of the parameter and the question mark (?). A value's unit must never be indicated. (The unit applicable to each parameter is indicated in Table 1–12.)

**Operating Commands, Parameters, and Queries**

Tables 1–11, 1–12, and 1–13 list the operating mode commands, command parameters, and queries of the LPB 1300 and LPB 1550 Tunable Laser Sources.

**Table 1–11: Definition of operating commands (GPIB)**

Mode command	Action
SCAN	Starts a wavelength scan. The scan will use the Smin, Smax, Step and Stime values.
STOP	Interrupts an ongoing wavelength scan.
DBM	Switches to the dBm mode.
MW	Switches to the mW mode.
ENABLE	Enables the laser output.
DISABLE	Disables the laser output.

Table 1–12 gives the parameters for the commands. Each “n” represents an integer from 0 to 9.

**Table 1–12: Command parameters (GPIB)**

Parameter command	Action
I=nn.n	Sets the laser diode current (mA) and switches to the constant current mode.
P=nn.nn	Sets the emitted power (mW). See MW, Table 1–11.
P=±n.nn	Sets the the emitted power (dBm). See DBM, Table 1–11.
L=nnnn.nnn	Sets the emission wavelength (nm).
f=nnnnnn.n	Sets the emission optical frequency (GHz).
FSCl=nn.n	Switches to the Fine Scanning mode. The numeric nn.n is the delta change in wavelength (pm). (Also available with the fine scanning option.)
FSCF=n.nn	Switches to the Fine Scanning mode. The numeric n.nn is the change in optical frequency (GHz). (Also available with the fine scanning option.)
Smin=nnnn.nnn	Sets the lower limit scanning wavelength (nm).
Smax=nnnn.nnn	Sets the upper limit scanning wavelength (nm).
Step=n.nnn	Sets the wavelength scan step (nm).
Stime=nn.n	Sets the stop time (seconds) between each scan step.
*SRE=nnn	Defines the conditions under which the tunable laser will automatically send a service request (SRQ) to the controller.
GPA D=nn	Defines the GPIB address of the tunable laser.
LCAL1 =nnnn.nnn	Defines the first calibration wavelength (nm).
LCAL2 =nnnn.nnn	Defines the second calibration wavelength (nm).
PCAL1 =nn.nn	Defines the calibration power (mW) of the first wavelength.
PCAL2 =nn.nn	Defines the calibration power (mW) of the second wavelength.
B_SUPPR=1	Enables backlash suppression irrespective of the previous state.
B_SUPPR=0	Disables backlash suppression irrespective of the previous state.

Table 1–13 lists the queries that ascertain the parameter settings and software version.

**Table 1–13: Queries (GPIB)**

Query	Action
I?	Asks for the value of the diode current (mA).
P?	Asks for the value of the optical power (mW or dBm). The unit is selected by the commands DBM or MW. See <i>Definition of Operating Modes</i> in Table 1–14.
L?	Asks for the value of the emission wavelength (nm).
f?	Asks for the value of the optical frequency (GHz).
*IDN?	Queries the tunable laser for the software version. The tunable laser returns the message "xxxxxx,n.nn" where n.nn is the software version number.

## Definition of Operating Modes

Table 1–14 lists the operating mode commands.

**Table 1–14: Operating mode commands (GPIB)**

Command	Action
APCON	Switch to constant power mode.
APCOFF	Switch to constant current mode.
SCAN	Initiate a wavelength scan. The scan uses the Smin, Smax, Step, and Stime values.
STOP	Stop scan.
DBM	Selects dBm unit for transmission of optical power values to and from the laser, and for displayed values.
MW	Selects mW unit for transmission of optical power values to and from the laser, and for displayed values.
ENABLE	Enables the optical output.
DISABLE	Disables the optical output.

- 
- Conditions of Use**     Some instructions can only be used under specific conditions:
- During a wavelength scan (SCAN instruction), only the request instructions for parameter's value and the instruction STOP are valid. All other commands will be ignored and will activate the ERRC (command error) indication.
  - The STOP instruction is only valid during a wavelength scan. If this instruction is transmitted without a scan in process, the ERRC (command error) indication will be activated.
- GPIB Standard**     The messages corresponding to the IEEE-488.1 standard are normally processed by the tunable laser, and are not specifically described here (refer to the IEEE-488.1 standard). All messages concerning the parallel polling are not executed by the tunable laser. Also, the tunable laser does not offer the extended addressing capability.
- Synchronization of Messages**     If successive instructions in a message do not interact (for example, setting all the scan parameters), several instructions can be contained in a single message. Several messages can be transmitted, even if previous messages have not been executed. If a given state is to be reached before some instruction is to be executed, it is preferable to make sure this state has been reached by reading the status word through the serial poll instruction.
- Provided that the tunable laser is not busy at another task, the tunable laser executes each instruction as soon it receives a complete instruction. (The instruction is completed with a semicolon (;), line feed (LF), or end-of-identify (EOI).) This implies that the tunable laser can execute some instructions even though the message is not completely transmitted. The tunable laser executes each successive instruction in sequence. To execute each instruction, the tunable laser decodes the character string and performs the following operations as necessary:
- Modify the operating state
  - Elaborate a response string
  - Modify some bits of the status word
- If the previous message included a request for the value of a parameter, the serial polling repeats until the MAV indicator in the status word is activated (MAV = 1). Only then can the computer read the requested value. If a single message contains several requests, the MAV bit stays true (1) until the computer reads all the response messages.

## Errors

Two types of errors can arise in the transmission of instructions: command errors and value errors.

The tunable laser detects command errors when the received string of characters does not correspond to an authorized instruction (syntax error or unknown mnemonic). The ERRC indicator in the status word is then activated.

A value error arises when the command is valid, but the value of the parameter is incorrect, either because it could not be read or because it is outside the valid range. In both cases, the received message is ignored and the ERRV indicator in the status word is activated.

### Definition of the Status Word

The 8-bit status word contains a number of binary indicators which can be used by the controller for an optimal synchronization between the tunable laser and the controller. They indicate to the controller the nature of the current operations as well as the errors encountered. These binary indicators are contained in the word sent by the tunable laser when the computer performs a serial polling. Table 1–15 gives the definition of each bit in the status word and when each bit is activated or deactivated.

**Table 1–15: Bits in status word (GPIB)**

Bit #	Mnemonic	Meaning	When activated/deactivated
7 (MSB)	SCANNING	Wavelength scan in progress	Activated at the beginning of a wavelength scan.  Deactivated at the end of the scan.
6	SRQ	Service request: request for controller intervention	Activated when an occurrence defined by the instruction *SRE arises.  Deactivated when it has been read by a serial poll.
5	ESB	(Reserved for future use)	(Reserved for future use; value is always 0)
4	MAV	Message available: a message is available for reading	Activated when the response to a parameter request is ready to be sent.  Deactivated when the response has been read and no other answer message is available.

Table 1–15: Bits in status word (GPIB) (Cont.)

Bit #	Mnemonic	Meaning	When activated/deactivated
3	LIM	Current limitation	Activated when the tunable laser is current-limited  Deactivated in all other cases.
2	ERRV	Error in received parameter value	Activated upon receipt of a parameter value which either has not been read, is erroneously formatted (e.g., the units have been indicated), or is outside the acceptable range (e.g., I=160).  Deactivated upon the reception of a correct instruction.
1	ERRC	Error in received command	Activated when an erroneous command has been received.  Deactivated when a valid command is received.
0	OPC	Operation complete: the operation has been completed; the laser is ready to receive a new instruction	Activated when no operation is in progress in the tunable laser.  Deactivated during the handling of commands (and also, during shifting of the drive to modify the wavelength emission). In particular, during scan operation, OPC bit is set to 0 each time the motor is moving and set back to 1 during the pause between successive steps.

**NOTE.** To detect errors that might occur after messages that contain only one instruction, test the *ERRV* and *ERRC* bits of the status word. When the message contains several instructions, the *ERRV* and *ERRC* flags are relevant to the last instruction only. To detect errors in messages with multiple instructions, activate the *SRE* bits corresponding to *ERRC* and *ERRV*, so that the tunable laser requests service as soon as it encounters an error.

**Reading the Status Word**

The computer can read the status word at any time by performing a serial poll. The computer checks the state of the different binary indicators to perform the next operation accordingly. Note the following recommendations for reading various bits of the status word:

- To be certain that changes to the wavelength, current, or power settings have stabilized, the computer should check the condition of the OPC indicator before sending an instruction that changes the settings again.
- After each instruction, check that the indicators ERRV and ERRC are deactivated (= 0) to verify that there were no transmission errors.
- When the computer requests a parameter value, check the state of the MAV indicator before reading the value. (If the reading is made before the message is available, the response of the tunable laser will be a string of empty characters ending with the line-feed character.)

The tunable laser updates the different indicators for the status word according to the state of the internal functions. When the computer reads the status word, the value corresponds to the actual state of the tunable laser and no memorization is performed. The different indicators are automatically activated or deactivated according to the criteria described above, even if no message is transmitted on the GPIB.

However, if the tunable laser activates a service request, the status word will not update until the serial poll is performed. (See below.)

**Service request (SRQ)**

The SRQ (service request) line is a part of the definition of the IEEE-488.1 standard. This line can be activated by all devices on the bus to alert the central controller that a particular device requires a particular operation.

When the controller detects that the SRQ line is active, it can question all of the devices present on the bus to determine which one has initiated the service request and for what reason. For this, it performs a serial poll, during which it will read the status word of each device (see Table 1–15 on page 1–32) which regroups the indicators permitting the controller to monitor the progress of the polling.

The IEEE-488.1 standard imposes the condition that Bit # 6 of the status word be set to 1 if the interrogated device has sent a service request. The other bits can reflect the state of different logical indicators of the tunable laser.

To facilitate the synchronization between the operations initiated by the computer and by the tunable laser, the computer can request the tunable laser to activate a service request when certain indicators move to 1 by using the instruction \*SRE. In this fashion, the computer will be warned that a particular occurrence has happened, without having to repetitively read the status word of the tunable laser to detect this occurrence.



The command \*SRE permits the definition of the conditions in which the tunable laser will perform a service request. The transmitted parameter with the instruction \*SRE must be an integer value between 0 and 255. If you write this value in the form of a binary byte of 8 bits, the binary elements (bits) which are at 1 validate the service request upon activation of the corresponding indicators of the status word.

For example, if the instruction \*SRE=16 is received by the tunable laser, this corresponds to the binary value 00010000. Since indicator #4 is set to one (indicator #4 = MAV = message available), the SRQ line will be automatically activated each time a message is available.

Different indicators can be set to 1 (true):

SCANNING	128	indicator #7
MAV	16	indicator #4
LIM	8	indicator #3
ERRV	4	indicator #2
ERRC	2	indicator #1
OPC	1	indicator #0

To calculate the parameter value to send with the instruction \*SRE, you must add the corresponding value of each of the indicators (bits) for which you wish a service request in case of activation. For example, to obtain a service request each time an error is made, you must send the instruction “\*SRE=6”, (obtained by adding the corresponding values of the two error indicators, which are ERRV (4) and ERRC(2)).

Once a service request has been activated by the tunable laser, the status word is no longer modified, as long as the controller does not perform a serial poll on the GPIB to read the status word of the tunable laser. This will allow the tunable laser’s indicators to remain in the state which they have had from the moment of the service request, so that the computer can analyze the cause of the service request.

---

**NOTE.** When a service request is received by the computer, a serial poll will be performed as soon as possible. No new instruction can be treated until the computer has performed the serial poll, since the processing of an instruction begins with the deactivation of the OPC indicator.

---

Once the status word is read, the service request is deactivated, and the normal activity of the tunable laser resumes.

### Changing the GPIB Address

At the time of the tunable laser’s factory configuration, its address on the GPIB is 10. To enter a new GPIB address, press 2ND > REMOTE > new address > ENTER.

This modification can also be performed with the IEEE-488.1 command: "GPAD=nn".

When the GPIB address has been modified, the new value is stored in protected memory, and it is therefore retained even if the tunable laser is turned off. This new value then replaces the initial value of the address, which is lost.

### **Local Lockout**

When the tunable laser receives a message through its IEEE-488.1 interface, it switches automatically to the remote mode of operation and the REMOTE indicator on the front panel lights up. In this operating mode, all keys of the front panel are deactivated. The local operating mode can be re-activated by pressing the REMOTE key.

If the message "Local lockout" is sent to the tunable laser through the GPIB, the Remote mode cannot be deactivated through the keys, and only the computer can set the tunable laser to the Local mode by sending the message "Go to local". In this case, the message "Local lockout" is displayed on the front panel if you press the REMOTE key.

# Specifications

This section contains the specifications for the LPB 1300 and LPB 1550 Tunable Laser Sources. All specifications are guaranteed unless noted as “typical.” Typical specifications are provided for your convenience but are not guaranteed. Specifications marked with the ✓ symbol have corresponding checks in the *Performance Verification* section on page 2–1.

**Table 1–16: Specifications**

Tuning	LPB 1300	LPB 1550
✓ Wavelength range (standard)	1260 nm to 1330 nm, P = 0 dBm – –	1500 nm to 1600 nm, P = 0 dBm 1530 nm to 1590 nm, P = 6 dBm (Opt. P6) 1535 nm to 1585 nm, P = 10 dBm (Opt. PX)
✓ Modified wavelength range (Option 1W)	1360 nm to 1420 nm, P = 0 dBm –	1520 nm to 1620 nm, P = 0 dBm 1540 nm to 1600 nm, P = 6 dBm (Opt. P6)
✓ Modified wavelength range (Option 2W)	– –	1540 nm to 1640 nm, P = 0 dBm 1580 nm to 1620 nm, P = 6 dBm (Opt. P6)
✓ Modified wavelength range (Option 3W)	– –	1480 nm to 1580 nm, P = 0 dBm 1510 nm to 1570 nm, P = 6 dBm (Opt. P6)
Mode hop spacing, typical	> 40 nm	> 70 nm
Tuning speed, typical	0.5 s (40 nm)	1 s (100 nm)
Optical wavelength modulation, typical (Input signal to FSC connector)	DC to 1 kHz, 200 MHz/V, ± 10 V max	DC to 1 kHz, 300 MHz/V, ± 10 V max
✓ Absolute wavelength accuracy	± 0.2 nm	
Tuning repeatability, typical	± 0.005 nm	
Wavelength setting resolution	0.001 nm	
Optical frequency fine tuning range, typical	± 2 GHz	
<b>Laser Output</b>		
✓ Output power	≥ rated output power over the entire wavelength range as per factory configuration. Refer to the wavelength range specifications listed under <i>Tuning</i> above.	
Power stability (P = 0 dBm, 1 hour)	± 0.01 dBm	
Linewidth, typical (FWHM, on mode hop free range)	Coherence control off: 150 kHz Coherence control on: > 100 MHz	
Side mode suppression ratio (SMSR)	> 45 dB	
Return loss, typical	– 60 dB	
Relative intensity noise (RIN), typical	< – 145 dB/Hz	

**Table 1–16: Specifications (Cont.)**

<b>Laser Output (cont.)</b>	
Output connector	FC/APC
Output fiber	Standard: single-mode fiber SMF-28 (yellow) Option 1M: polarization maintaining fiber (blue)
Low frequency modulation input	10 kHz to 8 MHz (DC to 8 MHz in current mode)
High frequency modulation input	30 kHz to > 1 GHz, mode lock frequency typically @ 5 GHz
<b>Power supply</b>	
Voltage range and power consumption	100 to 240 V $\pm$ 10%, 120 W maximum, CAT II
Frequency range	50 to 60 Hz $\pm$ 5%
Fuse rating	4A, 250 V, Slow (T)
<b>General</b>	
Temperature, maximum range for specified performance	Operating: +15 to +30° C Non-operating: –20 to +70° C
Humidity, maximum allowed for specified performance	Operating: 80% relative humidity to +30° C Non-operating: 80% relative humidity to +30° C, decreasing along a curve given by a +29° C wet bulb temperature (approximately 25% relative humidity at +50° C)
Remote control	IEEE-488.1-1987 RS-232-C
Weight	12.2 kg
Dimensions	Height: 133 mm Width: 448 mm Depth: 370 mm

Table 1–17 lists the optical specifications that pertain to the laser class according to IEC 60825-1, 21 CFR Part 1000, and EN 60825-1.

**Table 1–17: Laser class specifications**

<b>Name</b>	<b>Description</b>
Laser class	IIIb (according to 21 CFR 1040.10) 3A (according to EN60825-1)
Output power	< 20 mW
Output divergence (full angle @ 1/e <sup>2</sup> )	0.18 rad

Table 1–18 lists the applicable compliances for electromagnetic compatibility and safety.

**Table 1–18: Certifications and compliances**

Category	Standards or description
EC Declaration of Conformity – EMC	Meets intent of Directive 89/336/EEC for Electromagnetic Compatibility. Compliance was demonstrated to the following specifications as listed in the Official Journal of the European Union: EN 55011 Class A Radiated and Conducted Emissions EN 50082-1 Immunity: IEC 801-2 Electrostatic Discharge Immunity IEC 801-3 RF Electromagnetic Field Immunity IEC 801-4 Electrical Fast Transient/Burst Immunity
Australia/New Zealand Declaration of Conformity – EMC	Complies with EMC provision of Radiocommunications Act per the following standard(s): AS/NZS 2064.1/2 Industrial, Scientific, and Medical Equipment: 1992 AS/NZS 3548 Information Technology Equipment: 1995
EMC Compliance	Meets the intent of Directive 89/336/EEC for Electromagnetic Compatibility when it is used with the product(s) stated in the specifications table. Refer to the EMC specification published for the stated products. May not meet the intent of the directive if used with other products.
FCC Compliance	Emissions comply with FCC Code of Federal Regulations 47, Part 15, Subpart B, Class A Limits.
EC Declaration of Conformity – Low Voltage	Compliance was demonstrated to the following specification as listed in the Official Journal of the European Union: Low Voltage Directive 73/23/EEC, amended by 93/69/EEC EN 61010-1:1993/A2:1995 Safety requirements for electrical equipment for measurement control and laboratory use. EN 60825-1 Safety of Laser Products, Part 1. Equipment classification requirements and user's guide.
U.S. Nationally Recognized Testing Laboratory Listing	UL3111-1 Standard for electrical measuring and test equipment.
Canadian Certification	CAN/CSA C22.2 No. 1010.1 Safety requirements for electrical equipment for measurement, control, and laboratory use.
Additional Compliance	IEC61010-1/A2 Safety requirements for electrical equipment for measurement, control, and laboratory use. 21 CFR Part 1000 Performance Standards for Light-emitting products.
Installation (Overvoltage) Category	Terminals on this product may have different installation (overvoltage) category designations. The installation categories are: CAT III Distribution-level mains (usually permanently connected). Equipment at this level is typically in a fixed industrial location. CAT II Local-level mains (wall sockets). Equipment at this level includes appliances, portable tools, and similar products. Equipment is usually cord-connected. CAT I Secondary (signal level) or battery operated circuits of electronic equipment.

**Table 1–18: Certifications and compliances (Cont.)**

Category	Standards or description
Pollution Degree	<p>A measure of the contaminates that could occur in the environment around and within a product. Typically the internal environment inside a product is considered to be the same as the external. Products should be used only in the environment for which they are rated.</p> <p>Pollution Degree 1      No pollution or only dry, nonconductive pollution occurs. Products in this category are generally encapsulated, hermetically sealed, or located in clean rooms.</p> <p>Pollution Degree 2      Normally only dry, nonconductive pollution occurs. Occasionally a temporary conductivity that is caused by condensation must be expected. This location is a typical office/home environment. Temporary condensation occurs only when the product is out of service.</p> <p>Pollution Degree 3      Conductive pollution, or dry, nonconductive pollution that becomes conductive due to condensation. These are sheltered locations where neither temperature nor humidity is controlled. The area is protected from direct sunshine, rain, or direct wind.</p>
<b>Safety Certification Compliance</b>	
Temperature and humidity, safe operating	+5 to +40° C 80% relative humidity up to 31° C decreasing linearly to 50% at 40° C
Maximum altitude	2000 meters operating 5000 meters non–operating
Equipment Type	Test and measuring
Safety Class	Class 1 (as defined in IEC 61010-1, Annex H) – grounded product
Overvoltage Category	Overvoltage Category II (as defined in IEC 61010-1, Annex J)
Pollution Degree	Pollution Degree 2 (as defined in IEC 61010-1). Note: Rated for indoor use only.



# Service Information





# Performance Verification

Use the procedures in this section to verify the following warranted specifications of the LPB 1300 and LPB 1550 Tunable Laser Sources:

- Absolute wavelength accuracy
- Wavelength range
- Output power

The recommended calibration interval is two years.



**WARNING.** To avoid eye damage, do not look into the laser output or into the end of an optical cable. Even though the laser radiation is not visible, the intense infrared light can cause eye damage.

*Always disable laser output while connecting and disconnecting the optical fiber.*

Before beginning these procedures, identify any wavelength (W) and/or power (P) options; the tuning specifications vary according to these options. Identify and photocopy the appropriate test record at the end of this section.

## Equipment Required

Table 2–1 lists the equipment required to perform the performance verification procedure. The types and quantities of connectors may vary depending on the specific equipment you use and the distance between the test equipment and the tunable laser under test.

**Table 2–1: Test equipment**

Description	Minimum requirements	Example product
Optical power meter	Wavelength range: 1260 nm to 1640 nm Accuracy: $\pm 5\%$ or better, Power input rating: $>10$ dbm	Advantest Q8221 with Q82208 power sensor
Optical cable (1)	FC-FC singlemode, 9 $\mu\text{m}$ , 2 meters	174-1910-00
Wavemeter	Wavelength range: 1260 nm to 1600 nm Accuracy: $\pm 0.02$ nm or better	Burleigh WA1100

**Table 2-1: Test equipment (Cont.)**

Description	Minimum requirements	Example product
Jumper (supplied)	FC/APC to FC/PC	012-1564-00
Inline optical adapter	FC female to FC female	131-5039-00

## Preparation

Warm up the tunable laser under test and the test equipment for 60 minutes at an ambient temperature of 15° to 30° C.

### Initializing the System

For safe operation, use the following procedure to initialize the system:

1. Make sure the key on the front panel is in the Standby position.
2. Connect the power supply cable to the rear panel of the controller and then to the proper mains supply.
3. Set the rear-panel MAINS switch to on (I). See Figure 1-2 on page 1-12.
4. Turn the front panel on/off key to the right. During the initialization phase, the message “Initializing....” displays. This message clears once the laser is initialized and ready for operation.

At the end of the initialization, the message “Disabled...” appears on the display signifying that the laser output is ready to enable.



---

**CAUTION.** Avoid switching the unit off before the system is fully initialized.

---

After initialization, the cavity tunes to a wavelength near the center of the wavelength range.

The optical power setting initializes to zero when the laser is enabled.

### Cleaning the Optical Connections

For the best performance, optical connections must be clean and free of contamination. Cleaning instructions for optical connections are on page 2-17.

### Connecting the Laser Output

To connect the laser output, remove the protective cap and use a fiber with a FC/APC type connector.



---

**CAUTION.** To avoid damage to the laser output, always use a FC/APC type connector. To connect other styles, use the FC/PC to FC/APC jumper.

To help protect the laser output, leave a jumper cable in place when making connections to other devices. When the laser output is not connected, install the protective cap.

---

### Enabling the Laser Output

For safety reasons, the laser has an Enable button to enable or disable the output.

- To enable the laser output, press the Enable button. The Enable key lights.
- To disable the laser output, press the Enable button and check that the Enable light goes off.

### Shutting Down the Laser

To shut down the laser, turn the front panel key left to the standby position. The message “Parking...” displays and the optical head automatically moves to the parking position. After a few seconds, the system shuts down by itself.



---

**CAUTION.** Avoid switching the unit off before the system is fully initialized. After turning the laser to standby, wait at least thirty seconds before initializing the laser again.

---

## Absolute Wavelength Accuracy

This procedure verifies that the wavelength settings agree with the measured wavelengths. If necessary, it is possible to replace the factory calibration for wavelength with user selected values. Refer to the procedure on page 1–16.



---

**CAUTION.** Calibrating the wavelength settings from the front panel erases the factory calibration data.

---

1. Connect the laser to the wavemeter.
2. Set the output power to the rated output power of the laser using the front panel controls.

3. Set the wavelength of the tunable laser and the power meter to the low limit of the wavelength range according to the wavelength option listed in Table 2–2 ( $\lambda >$  wavelength value in nm  $>$  ENTER).
4. Enable the laser output and verify the wavelength at the low limit  $\pm 0.2$  nm.
5. Repeat the check for each increment of 10 nm from the low limit to the high limit listed in Table 2–2. For ease of operation, use the STEP function to enter the step increment and then use the  $\rightarrow$  key to increment the wavelength setting.
6. Verify the measured wavelength is no greater than  $\pm 0.2$  nm away from each wavelength setting.

Table 2–2: Wavelength range

Model	Wavelength option	Power option	Low limit	High limit
LPB 1300	Standard	Standard (P = 0 dBm)	1260 nm	1330 nm
	1W	Standard (P = 0 dBm)	1360 nm	1420 nm
LPB 1550	Standard	Standard (P = 0 dBm)	1500 nm	1600 nm
		P6 (P = 6 dBm)	1530 nm	1590 nm
		PX (P = 10 dBm)	1535 nm	1585 nm
	1W	Standard (P = 0 dBm)	1520 nm	1620 nm
		P6 (P = 6 dBm)	1540 nm	1600 nm
	2W	Standard (P = 0 dBm)	1540 nm	1640 nm
		P6 (P = 6 dBm)	1580 nm	1620 nm
	3W	Standard (P = 0 dBm)	1480 nm	1580 nm
P6 (P = 6 dBm)		1510 nm	1570 nm	

## Wavelength Range and Output Power

This procedure verifies that the laser output can achieve the rated power at the specified limits of the wavelength range. If necessary, it is possible to replace the factory calibration for power with user selected values. Refer to the procedure on page 1–17.



**CAUTION.** Calibrating the power settings from the front panel erases the factory calibration data.

1. Disable the laser output.
2. Connect the laser to the optical power meter.

3. Set the wavelength of the tunable laser and the power meter to the low limit of the wavelength range listed in Table 2–2.
4. Enable the laser output and adjust the power setting as necessary to verify that the laser can achieve the rated output power at the low limit of the wavelength range.

---

***NOTE.** Increase the power setting as necessary to bring the measured value up to the rated value. This test verifies that the tunable laser can achieve the rated output regardless of the accuracy of the power setting.*

---

5. Repeat the check for each increment of 10 nm from the low limit to the high limit listed in Table 2–2.

**LPB 1300 test record – standard wavelength, standard power**

Model/Serial Number: LPB 1300 \_\_\_\_\_ Certificate Number: \_\_\_\_\_  
 Temperature: \_\_\_\_\_ RH %: \_\_\_\_\_  
 Date: \_\_\_\_\_ Technician: \_\_\_\_\_

Standard wavelength, standard power	Minimum	Incoming	Outgoing	Maximum
Absolute wavelength accuracy ± 0.2 nm @ 0 dBm, 1260 nm to 1330 nm	1259.8 nm			1260.2 nm
	1269.8 nm			1270.2 nm
	1279.8 nm			1280.2 nm
	1289.8 nm			1290.2 nm
	1299.8 nm			1300.2 nm
	1309.8 nm			1310.2 nm
	1319.8 nm			1320.2 nm
	1329.8 nm			1330.2 nm
Wavelength range and power 1260 nm to 1330 nm, ≥ 0 dBm	1260 nm, 0 dBm	dBm	dBm	N/A
	1270 nm, 0 dBm	dBm	dBm	N/A
	1280 nm, 0 dBm	dBm	dBm	N/A
	1290 nm, 0 dBm	dBm	dBm	N/A
	1300 nm, 0 dBm	dBm	dBm	N/A
	1310 nm, 0 dBm	dBm	dBm	N/A
	1320 nm, 0 dBm	dBm	dBm	N/A
	1330 nm, 0 dBm	dBm	dBm	N/A

**LPB 1300 test record – Option 1W wavelength, standard power**

Model/Serial Number: LPB 1300 \_\_\_\_\_ Certificate Number: \_\_\_\_\_  
 Temperature: \_\_\_\_\_ RH %: \_\_\_\_\_  
 Date: \_\_\_\_\_ Technician: \_\_\_\_\_

Option 1W wavelength, standard power	Minimum	Incoming	Outgoing	Maximum
Absolute wavelength accuracy ± 0.2 nm @ 0 dBm, 1360 nm to 1420 nm	1359.8 nm			1360.2 nm
	1369.8 nm			1370.2 nm
	1379.8 nm			1380.2 nm
	1389.8 nm			1390.2 nm
	1399.8 nm			1400.2 nm
	1409.8 nm			1410.2 nm
	1419.8 nm			1420.2 nm
Wavelength range and power 1360 nm to 1420 nm, ≥ 0 dBm	1360 nm, 0 dBm			N/A
	1370 nm, 0 dBm			N/A
	1380 nm, 0 dBm			N/A
	1390 nm, 0 dBm			N/A
	1400 nm, 0 dBm			N/A
	1410 nm, 0 dBm			N/A
	1420 nm, 0 dBm			N/A

**LPB 1550 test record – standard wavelength, standard power**

Model/Serial Number: LPB 1550 \_\_\_\_\_ Certificate Number: \_\_\_\_\_  
 Temperature: \_\_\_\_\_ RH %: \_\_\_\_\_  
 Date: \_\_\_\_\_ Technician: \_\_\_\_\_

Standard wavelength, standard power	Minimum	Incoming	Outgoing	Maximum
Absolute wavelength accuracy ± 0.2 nm @ 0 dBm, 1500 nm to 1600 nm	1499.8 nm			1500.2 nm
	1509.8 nm			1510.2 nm
	1519.8 nm			1520.2 nm
	1529.8 nm			1530.2 nm
	1539.8 nm			1540.2 nm
	1549.8 nm			1550.2 nm
	1559.8 nm			1560.2 nm
	1569.8 nm			1570.2 nm
	1579.8 nm			1580.2 nm
	1589.8 nm			1590.2 nm
	1599.8 nm			1600.2 nm
Wavelength range and power 1500 nm to 1600 nm, ≥ 0 dBm	1500 nm, 0 dBm	dBm	dBm	N/A
	1510 nm, 0 dBm	dBm	dBm	N/A
	1520 nm, 0 dBm	dBm	dBm	N/A
	1530 nm, 0 dBm	dBm	dBm	N/A
	1540 nm, 0 dBm	dBm	dBm	N/A
	1550 nm, 0 dBm	dBm	dBm	N/A
	1560 nm, 0 dBm	dBm	dBm	N/A
	1570 nm, 0 dBm	dBm	dBm	N/A
	1580 nm, 0 dBm	dBm	dBm	N/A
	1590 nm, 0 dBm	dBm	dBm	N/A
	1600 nm, 0 dBm	dBm	dBm	N/A



**LPB 1550 test record – standard wavelength, Option P6 power**

Model/Serial Number: LPB 1550 \_\_\_\_\_ Certificate Number: \_\_\_\_\_  
 Temperature: \_\_\_\_\_ RH %: \_\_\_\_\_  
 Date: \_\_\_\_\_ Technician: \_\_\_\_\_

Standard wavelength, Option P6 power	Minimum	Incoming	Outgoing	Maximum
Absolute wavelength accuracy ± 0.2 nm @ 6 dBm, 1530 nm to 1590 nm	1529.8 nm			1530.2 nm
	1539.8 nm			1540.2 nm
	1549.8 nm			1550.2 nm
	1559.8 nm			1560.2 nm
	1569.8 nm			1570.2 nm
	1579.8 nm			1580.2 nm
	1589.8 nm			1590.2 nm
Wavelength range and power 1530 nm to 1590 nm, ≥ 6 dBm	1530 nm, 6 dBm	dBm	dBm	N/A
	1540 nm, 6 dBm	dBm	dBm	N/A
	1550 nm, 6 dBm	dBm	dBm	N/A
	1560 nm, 6 dBm	dBm	dBm	N/A
	1570 nm, 6 dBm	dBm	dBm	N/A
	1580 nm, 6 dBm	dBm	dBm	N/A
	1590 nm, 6 dBm	dBm	dBm	N/A

Performance Verification

---

**LPB 1550 test record – standard wavelength, Option PX power**

Model/Serial Number: LPB 1550 \_\_\_\_\_ Certificate Number: \_\_\_\_\_  
 Temperature: \_\_\_\_\_ RH %: \_\_\_\_\_  
 Date: \_\_\_\_\_ Technician: \_\_\_\_\_

Standard wavelength, Option PX power	Minimum	Incoming	Outgoing	Maximum
Absolute wavelength accuracy ± 0.2 nm @ 10 dBm, 1535 nm to 1585 nm	1534.8 nm			1535.2 nm
	1544.8 nm			1545.2 nm
	1554.8 nm			1555.2 nm
	1564.8 nm			1565.2 nm
	1574.8 nm			1575.2 nm
	1584.8 nm			1585.2 nm
Wavelength range and power 1535 nm to 1585 nm, ≥ 10 dBm	1535 nm, 10dBm	dBm	dBm	N/A
	1545 nm, 10dBm	dBm	dBm	N/A
	1555 nm, 10dBm	dBm	dBm	N/A
	1565 nm, 10dBm	dBm	dBm	N/A
	1575 nm, 10dBm	dBm	dBm	N/A
	1585 nm, 10dBm	dBm	dBm	N/A

**LPB 1550 test record – Option 1W wavelength, standard power**

Model/Serial Number: LPB 1550 \_\_\_\_\_ Certificate Number: \_\_\_\_\_  
 Temperature: \_\_\_\_\_ RH %: \_\_\_\_\_  
 Date: \_\_\_\_\_ Technician: \_\_\_\_\_

Option 1 W wavelength, standard power	Minimum	Incoming	Outgoing	Maximum
Absolute wavelength accuracy ± 0.2 nm @ 0 dBm, 1520 nm to 1620 nm	1519.8 nm			1520.2 nm
	1529.8 nm			1530.2 nm
	1539.8 nm			1540.2 nm
	1549.8 nm			1550.2 nm
	1559.8 nm			1560.2 nm
	1569.8 nm			1570.2 nm
	1579.8 nm			1580.2 nm
	1589.8 nm			1590.2 nm
	1599.8 nm			1600.2 nm
	1609.8 nm			1610.2 nm
	1619.8 nm			1620.2 nm
Wavelength range and power 1520 nm to 1620 nm, ≥ 0 dBm	1520 nm, 0 dBm	dBm	dBm	N/A
	1530 nm, 0 dBm	dBm	dBm	N/A
	1540 nm, 0 dBm	dBm	dBm	N/A
	1550 nm, 0 dBm	dBm	dBm	N/A
	1560 nm, 0 dBm	dBm	dBm	N/A
	1570 nm, 0 dBm	dBm	dBm	N/A
	1580 nm, 0 dBm	dBm	dBm	N/A
	1590 nm, 0 dBm	dBm	dBm	N/A
	1600 nm, 0 dBm	dBm	dBm	N/A
	1610 nm, 0 dBm	dBm	dBm	N/A
	1620 nm, 0 dBm	dBm	dBm	N/A

**LPB 1550 test record – Option 1W wavelength, Option P6 power**

Model/Serial Number: LPB 1550 \_\_\_\_\_ Certificate Number: \_\_\_\_\_  
 Temperature: \_\_\_\_\_ RH %: \_\_\_\_\_  
 Date: \_\_\_\_\_ Technician: \_\_\_\_\_

Option 1W wavelength, Option P6 power	Minimum	Incoming	Outgoing	Maximum
Absolute wavelength accuracy ± 0.2 nm @ 6 dBm, 1540 nm to 1600 nm	1539.8 nm			1540.2 nm
	1549.8 nm			1550.2 nm
	1559.8 nm			1560.2 nm
	1569.8 nm			1570.2 nm
	1579.8 nm			1580.2 nm
	1589.8 nm			1590.2 nm
	1599.8 nm			1600.2 nm
Wavelength range and power 1540 nm to 1600 nm, ≥ 6 dBm	1540 nm, 6 dBm	dBm	dBm	N/A
	1550 nm, 6 dBm	dBm	dBm	N/A
	1560 nm, 6 dBm	dBm	dBm	N/A
	1570 nm, 6 dBm	dBm	dBm	N/A
	1580 nm, 6 dBm	dBm	dBm	N/A
	1590 nm, 6 dBm	dBm	dBm	N/A
	1600 nm, 6 dBm	dBm	dBm	N/A

**LPB 1550 test record – Option 2W wavelength, standard power**

Model/Serial Number: LPB 1550 \_\_\_\_\_ Certificate Number: \_\_\_\_\_  
 Temperature: \_\_\_\_\_ RH %: \_\_\_\_\_  
 Date: \_\_\_\_\_ Technician: \_\_\_\_\_

Option 2W wavelength, standard power	Minimum	Incoming	Outgoing	Maximum
Absolute wavelength accuracy ± 0.2 nm @ 0 dBm, 1540 nm to 1640 nm	1539.8 nm			1540.2 nm
	1549.8 nm			1550.2 nm
	1559.8 nm			1560.2 nm
	1569.8 nm			1570.2 nm
	1579.8 nm			1580.2 nm
	1589.8 nm			1590.2 nm
	1599.8 nm			1600.2 nm
	1609.8 nm			1610.2 nm
	1619.8 nm			1620.2 nm
	1629.8 nm			1630.2 nm
	1639.8 nm			1640.2 nm
Wavelength range and power 1540 nm to 1640 nm, ≥ 0 dBm	1540 nm, 0 dBm	dBm	dBm	N/A
	1550 nm, 0 dBm	dBm	dBm	N/A
	1560 nm, 0 dBm	dBm	dBm	N/A
	1570 nm, 0 dBm	dBm	dBm	N/A
	1580 nm, 0 dBm	dBm	dBm	N/A
	1590 nm, 0 dBm	dBm	dBm	N/A
	1600 nm, 0 dBm	dBm	dBm	N/A
	1610 nm, 0 dBm	dBm	dBm	N/A
	1620 nm, 0 dBm	dBm	dBm	N/A
	1630 nm, 0 dBm	dBm	dBm	N/A
	1640 nm, 0 dBm	dBm	dBm	N/A

**LPB 1550 test record – Option 2W wavelength, Option P6 power**

Model/Serial Number: LPB 1550 \_\_\_\_\_ Certificate Number: \_\_\_\_\_  
 Temperature: \_\_\_\_\_ RH %: \_\_\_\_\_  
 Date: \_\_\_\_\_ Technician: \_\_\_\_\_

Option 2W wavelength, Option P6 power	Minimum	Incoming	Outgoing	Maximum
Absolute wavelength accuracy ± 0.2 nm @ 6 dBm, 1580 nm to 1620 nm	1579.8 nm			1580.2 nm
	1589.8 nm			1590.2 nm
	1599.8 nm			1600.2 nm
	1609.8 nm			1610.2 nm
	1619.8 nm			1620.2 nm
Wavelength range and power 1580 nm to 1620 nm, ≥ 6 dBm	1580 nm, 6 dBm	dBm	dBm	N/A
	1590 nm, 6 dBm	dBm	dBm	N/A
	1600 nm, 6 dBm	dBm	dBm	N/A
	1610 nm, 6 dBm	dBm	dBm	N/A
	1620 nm, 6 dBm	dBm	dBm	N/A

**LPB 1550 test record – Option 3W wavelength, standard power**

Model/Serial Number: LPB 1550 \_\_\_\_\_ Certificate Number: \_\_\_\_\_  
 Temperature: \_\_\_\_\_ RH %: \_\_\_\_\_  
 Date: \_\_\_\_\_ Technician: \_\_\_\_\_

Option 3W wavelength, standard power	Minimum	Incoming	Outgoing	Maximum
Absolute wavelength accuracy ± 0.2 nm @ 0 dBm, 1480 nm to 1580 nm	1479.8 nm			1480.2 nm
	1489.8 nm			1490.2 nm
	1499.8 nm			1500.2 nm
	1509.8 nm			1510.2 nm
	1519.8 nm			1520.2 nm
	1529.8 nm			1530.2 nm
	1539.8 nm			1540.2 nm
	1549.8 nm			1550.2 nm
	1559.8 nm			1560.2 nm
	1569.8 nm			1570.2 nm
	1579.8 nm			1580.2 nm
Wavelength range and power 1480 nm to 1580 nm, ≥ 0 dBm	1480 nm, 0 dBm	dBm	dBm	N/A
	1490 nm, 0 dBm	dBm	dBm	N/A
	1500 nm, 0 dBm	dBm	dBm	N/A
	1510 nm, 0 dBm	dBm	dBm	N/A
	1520 nm, 0 dBm	dBm	dBm	N/A
	1530 nm, 0 dBm	dBm	dBm	N/A
	1540 nm, 0 dBm	dBm	dBm	N/A
	1550 nm, 0 dBm	dBm	dBm	N/A
	1560 nm, 0 dBm	dBm	dBm	N/A
	1570 nm, 0 dBm	dBm	dBm	N/A
	1580 nm, 0 dBm	dBm	dBm	N/A

**LPB 1550 test record – Option 3W wavelength, Option P6 power**

Model/Serial Number: LPB 1550 \_\_\_\_\_ Certificate Number: \_\_\_\_\_  
 Temperature: \_\_\_\_\_ RH %: \_\_\_\_\_  
 Date: \_\_\_\_\_ Technician: \_\_\_\_\_

Option 3W wavelength, Option P6 power	Minimum	Incoming	Outgoing	Maximum
Absolute wavelength accuracy ± 0.2 nm @ 6 dBm, 1510 nm to 1570 nm	1509.8 nm			1510.2 nm
	1519.8 nm			1520.2 nm
	1529.8 nm			1530.2 nm
	1539.8 nm			1540.2 nm
	1549.8 nm			1550.2 nm
	1559.8 nm			1560.2 nm
	1569.8 nm			1570.2 nm
Wavelength range and power 1510 nm to 1570 nm, ≥ 6 dBm	1510 nm, 6 dBm	dBm	dBm	N/A
	1520 nm, 6 dBm	dBm	dBm	N/A
	1530 nm, 6 dBm	dBm	dBm	N/A
	1540 nm, 6 dBm	dBm	dBm	N/A
	1550 nm, 6 dBm	dBm	dBm	N/A
	1560 nm, 6 dBm	dBm	dBm	N/A
	1570 nm, 6 dBm	dBm	dBm	N/A



# Maintenance

User maintenance of the LPB 1300 and LPB 1550 Tunable Laser Sources is limited to the following:

- Cleaning optical connectors as necessary for optimum power.
- Checking the performance of optical connections and cables.
- Verifying the performance of the tunable laser against the warranted specifications listed on page 1–37.
- Replacing the line fuse
- Cleaning the exterior parts of the instrument



---

**WARNING.** *There are no user serviceable parts inside the cover of the instrument. Refer servicing of internal parts to Tektronix authorized personnel only.*

---

External parts may be replaced by qualified service personnel. For a list of replaceable parts, see page 2–21.

## Cleaning and Caring for Optical Connectors and Fibers

Handle optical fiber with appropriate care and preserve the integrity of optical connectors by keeping them free of contamination.



---

**CAUTION.** *To optimize the performance of the system and prevent loss of optical power or damage to the optical connectors, keep the connectors clean at all times.*

*When cleaning the connectors with a swab, use gentle circular motions. Use only high quality cleaning supplies that are non-abrasive and leave no residue.*

*To reduce the need for cleaning, immediately replace protective caps on the optical connectors when not in use.*

*Do not over stress or sharply bend the optical fiber beyond tolerances specified by the manufacturer.*

---

### Equipment Required

Use the following items to clean the optical connectors:

- clean compressed air
- fiber-optic cleaning swabs
- isopropyl alcohol

### Procedure

To clean the optical connectors, follow these steps:

1. Hold the can of compressed air upright and spray the can into the air to purge any propellant.
2. Spray the clean compressed air on the connectors to remove any loose particles or moisture.
3. Moisten a clean optical swab with isopropyl alcohol and then lightly swab the surfaces of the connectors.
4. Spray the clean compressed air on the connectors again to remove any loose particles or isopropyl alcohol.

---

**NOTE.** *Cleaning kits for optical connectors are available from many fiber optic suppliers.*

---

## Calibration

To externally verify the performance of the LPB 1300 and LPB 1550 Tunable Laser Sources, refer to the procedure that begins on page 2–1. If the performance does not meet warranted specifications, a complete calibration of the instrument may be required.

Some calibration steps require the adjustment of internal components including the laser head; therefore, a complete calibration must be performed by Tektronix authorized personnel only.

The tunable laser does allow for user calibration of wavelength and power. To do this, the user must replace the factory calibrated settings with user selected values. For details, see pages 1–16 and 1–17.



---

**CAUTION.** *To avoid damaging the laser head, refer the servicing of all internal components and to Tektronix authorized personnel only. Under no circumstance may the user perform any service or maintenance on the laser head.*

---

## Replacing the Line Fuse

The line fuse is located on the rear panel in the mains module that connects to the power cord (see Figure 2–1). Refer to page 2–21 for replaceable parts information.

To replace the line fuse, follow these steps:

1. Insert a small flat-blade screwdriver into the notch just inside the power cord socket of the line filter. Use the notch to pull the fuse holder straight out to remove the fuse.
2. Replace the fuse in the fuse holder and snap the fuse holder back into the lined filter.

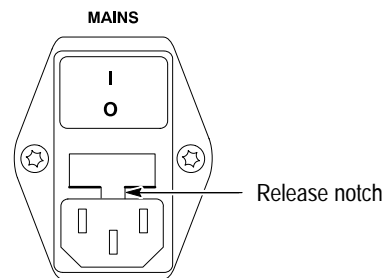

Figure 2–1: Accessing the line fuse

## Cleaning the Exterior

To clean the exterior parts of the instrument, follow these steps

1. Remove loose dust on the exterior with a lint free cloth.
2. Remove remaining dirt with a lint free cloth dampened in a general purpose detergent-and-water solution. Do not use abrasive cleaners.
3. Clean the display area with a lint-free cloth dampened with either isopropyl alcohol or, preferably, a gentle, general purpose detergent-and-water solution.



**CAUTION.** To prevent getting moisture inside the instrument during external cleaning, use only enough liquid to dampen the cloth or applicator.

## Packaging for Shipment

Use the original packaging to return the tunable laser to Tektronix for service or calibration. For instructions on returning the instrument, contact Tektronix. See page vii for details.

# Replaceable Parts

For information about replaceable parts, contact your Tektronix sales representative.



**WARNING.** There are no user serviceable parts inside the cover of the instrument. Refer servicing of internal parts to Tektronix authorized personnel only. External parts may be replaced by qualified service personnel.

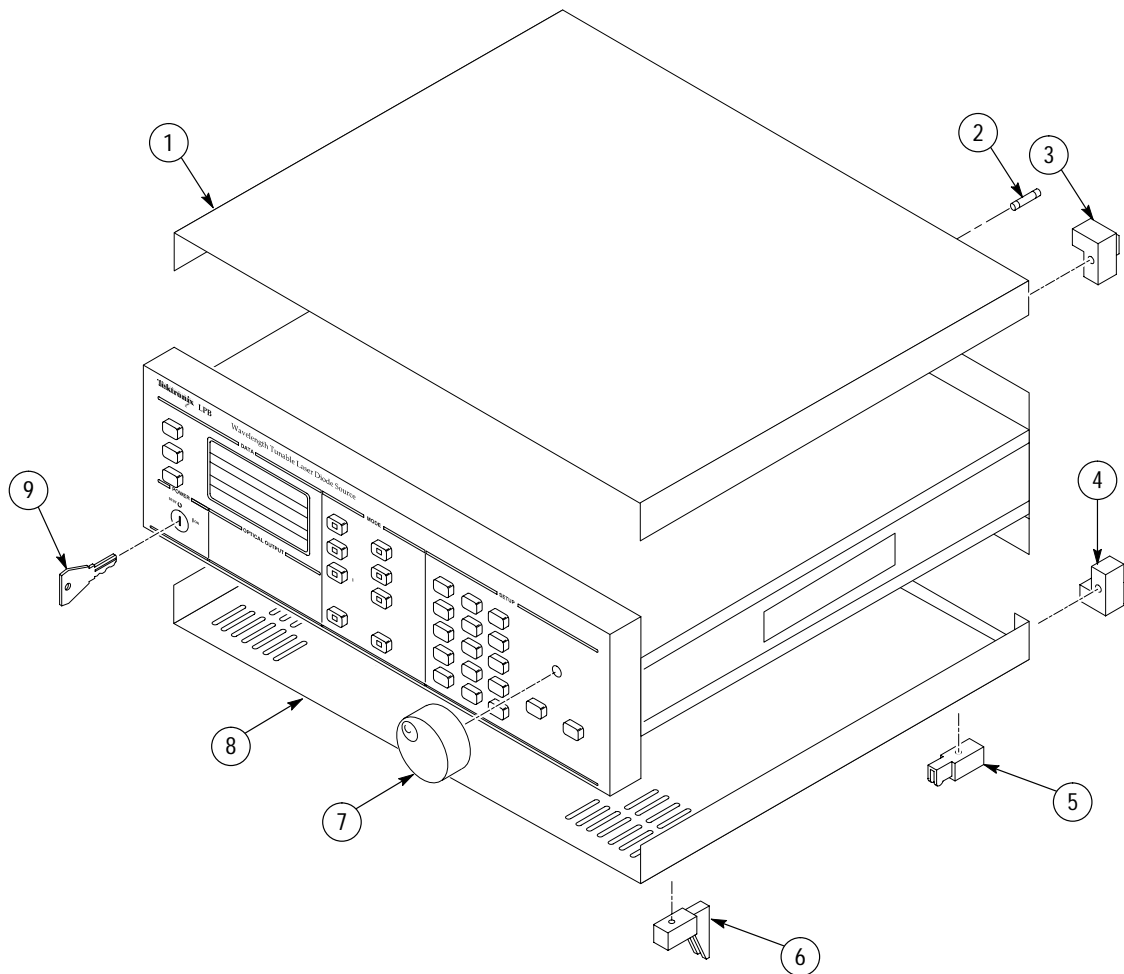

Figure 2-2: Replaceable parts

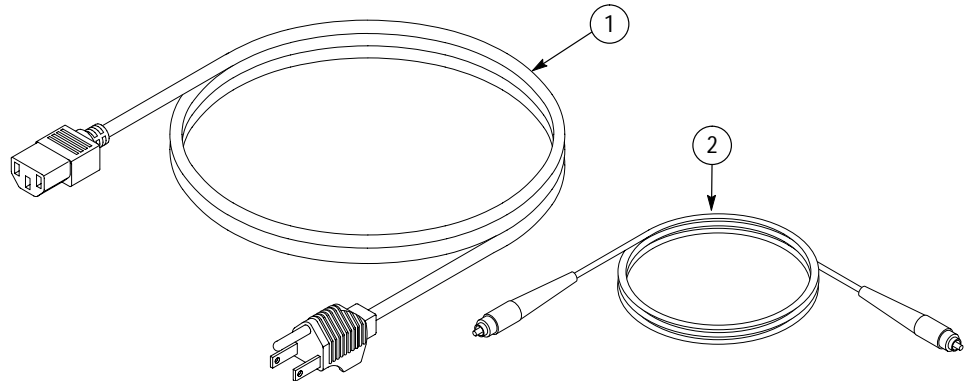

Figure 2-3: Standard accessories

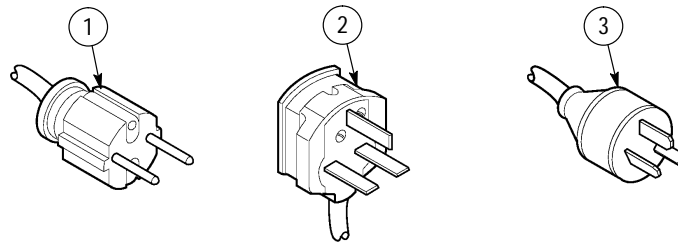

Figure 2-4: Optional power cords

Replaceable parts list

Fig. & index number	Tektronix part number	Serial no. effective	Serial no. discont'd	Qty	Name & description	Mfr. code	Mfr. part number
2-2-1	Not available at time of printing				cover, top	80009	Not available at time of printing
-2	"				fuse, line 4A, 250 V, Slow (T), maximum power 120 W	80009	"
-3	"				rear bumper, top left and bottom right	80009	"
-4	"				rear bumper, bottom left and top right	80009	"
-5	"				foot, bottom rear	80009	"
-6	"				foot, bottom front	80009	"
-7	"				knob, tuning	80009	"
-8	"				cover, bottom	80009	"
-9	105-1125-00				KEY: FRONT PANEL ON/OFF,AL	80009	105-1125-00
					<b>Standard accessories</b>		
2-3-1	161-0066-00			1	CA ASSY,PWR:3,18 AWG,250V/10A,98 INCH,STR,IEC320,RCPT X NEMA 5-15P,US,SAFETY CONTROLLED	0B445	ECM-161-0066-00

## Replaceable parts list (cont.)

Fig. & index number	Tektronix part number	Serial no. effective	Serial no. discont'd	Qty	Name & description	Mfr. code	Mfr. part number
-2	012-1564-00			1	CABLE,FIBER OPTFC/APC TO FC/PC Single-mode fiber (standard, yellow jacket)	80009	012-1564-00
	012-1566-00			1	CABLE,FIBER OPTFC/APC TO FC/PC Polarization Maintaining (Option 1M, blue jacket)	80009	012-1566-00
—	071-0587-00			1	MANUAL,TECH:INSTRUCTION LPB 1300 and LPB 1550	80009	071-0587-00
<b>Optional Power Cords</b>							
2-4-1	161-0066-09			1	CA ASSY,PWR:3.0.75MM SQ,250V/10A,99 INCH,STR,IEC320,RCPT,EUROPEAN,	2W733	ORDER BY DESCRIPTION
-2	161-0066-10			1	CA ASSY,PWR:3.1.0 MM SQ,250V/10A,2.5 METER,STR,IEC320,RCPT X 13A,FUSED UK PLUG(13A FUSE)	TK2541	ORDER BY DESCRIPTION
-3	161-0066-11			1	CA ASSY,PWR:3.1.0MM SQ,250V/10A,2.5 METER,STR,IEC320,RCPT,AUSTRALIA,SAFETY CONTROLLED	80126	ORDER BY DESCRIPTION

## Manufacturers cross index

Mfr. code	Manufacturer	Address	City, state, zip code
0B445	ELECTRI-CORD MFG CO INC	312 EAST MAIN STREET	WESTFIELD, PA 16950
2W733	BELDEN WIRE & CABLE COMPANY	2200 US HWY 27 SOUTH PO BOX 1980	RICHMOND, IN 47374
80009	TEKTRONIX INC	14150 SW KARL BRAUN DR PO BOX 500	BEAVERTON, OR 97077-0001
80126	PACIFIC ELECTRICORD CO	747 WEST REDONDO BEACH PO BOX 10	GARDENA, CA 90247-4203
TK2541	AMERICOR ELECTRONICS LTD	UNIT-H 2682 W COYLE AVE	ELK GROVE VILLAGE, IL 60007







# Appendices



# Appendix A: Parameters

Table A-1: Valid range of parameter settings

Parameter	Valid range
Maximum laser diode current level (I)	See calibration data (Valid only for applications that require modulating the current level)
Upper and lower wavelength scan limits	$\geq$ the specified wavelength range <sup>1</sup>
Beam output power (P)	0.2 to 20 mW <sup>1</sup>
Wavelength scan steps	0.001 to 150 nm
Time at each scan step	0.1 to 25 seconds

<sup>1</sup> Valid settings vary according to the wavelength option and power option. See specifications for wavelength range and power on page 1-37.



## Appendix B: Error Messages

Table B–1 shows the error messages of the LPB 1300 and LPB 1550 Tunable Laser Sources.

**Table B–1: Error Messages**

Displayed message	Significance	Action to take
WARNING: User calib. err press "enter"	User calibration not correct	Use the default value instead of the user calibration.
ERROR: no factory calib. turn power off	No factory calibration	Switch off the system. Test the electrical connections. If the same message is displayed, call Tektronix for service.
DEFAULT Laser head disconnected	No connection between the head and the controller	Switch off the system, test the electrical connections. If the same message is displayed, call the service engineer.
Value error Press Enter	The entered value is not in the valid range	Press Enter. The modification is canceled. The previous value is kept unchanged.
Limit Switch Turn Power off	Mechanical problem	Switch the system off and call Tektronix for service.
EEPROM error Turn Power off	Electrical problem	Switch the system off and call the service engineer.



# Appendix C: RS-232-C Control Commands

Table C–1 lists the set of RS-232-C control commands sent from an instrument controller and the response that the controller should receive from the LPB 1300 and LPB 1550 Tunable Laser Sources.

Table C–1: Summary of RS-232-C control commands

Command	Action	Response
I=nn.n	Sets diode laser current level (mA)	OK
P=nn.nn	Sets power output level (mW)	OK
P=(±)nn.nn	Sets power output level (dBm)	OK
L=nnnn.nnn	Sets emission wavelength (nm)	OK
f=nnnnnn.n	Sets emission optical frequency (GHz)	OK
FSCl=nn.n	Sets fine scanning mode (pm)	OK
FSCF=n.nn	Sets fine scanning mode (GHz)	OK
Smin=nnnn.nn	Sets lower scan wavelength limit (nm)	OK
Smax=nnnn.nn	Sets upper scan wavelength limit (nm)	OK
Step=nn.nnn	Sets scan step value (nm)	OK
Stime=n.n	Sets scan step time (s)	OK
APCON	Switches system to constant power mode	OK
APCOFF	Switches to constant current mode	OK
MW	Sets power unit to mW	OK
DBM	Sets power unit to dBm	OK
SCAN	Initiates scan (Message when the scan is complete)	Scanning... End of scan
STOP	Terminates scan in progress	End of scan
ECHON	All characters sent to be echoed on remote screen	OK
ECHOFF	Cancel echo mode	OK
INIT	Initialize optical head	OK
ENABLE	Enables the laser output	OK
DISABLE	Disables the laser output	OK
I?	Requests present current level (mA)	I=nn.n
P?	Requests present power output level  mW unit active :  dBm unit active :	P=nn.nn  P=±nn.nn

Table C-1: Summary of RS-232-C control commands (Cont.)

Command	Action	Response
L?	Requests present emission wavelength (nm)	L=nnnn.nnn
f?	Requests present emission frequency (GHz)	f=nnnnnn.n

## Space Characters

Except for the carriage return character (ASCII code 13), the tunable laser interprets all characters with ASCII codes lower than or equal to 32 as space characters.

## Message Termination

The tunable laser terminates all messages with the following characters:

- return character ( $\r$ )
- greater than character ( $>$ )
- space character ( )



# Appendix D: IEEE-488.1 Control Command Summary

Observe the following rules for sending messages to LPB 1300 and LPB 1550 Tunable Laser Sources from the bus controller:

- If a message contains several instructions, separate the instructions with semicolon characters (;).
- Terminate each message in one of the following three ways: (1) by the character LF (ASCII 10), or (2) by activating the EOI line of the bus, or (3) by both together.
- Before sending a new message to, or reading an answer from the tunable laser, check that the “status word” answered by the serial poll corresponds to previous actions. Otherwise, errors may occur due to lack of synchronization between controller and the tunable laser.
- On the IEEE-488.1 interface, space characters are all characters whose ASCII code is smaller than or equal to 32 except the line feed character (ASCII code 10).

Table D–1 summarizes the IEEE-488.1 control commands used by the LPB 1300 and LPB 1550 Tunable Laser Sources.

**Table D–1: Summary of IEEE-488.1 control commands**

Command	Action	Set/clear status bits
I=nn.n	Sets diode laser current level (mA)	0
P=nn.nn	Sets power output level (mW mode active)	0,3
P=(±)nn.nn	Sets power output level (dBm mode active)	0,3
L=nnnn.nnn	Sets emission wavelength (nm)	0,3
f=nnnnnn.n	Sets emission frequency (GHz)	0,3
FSCL=nn.n	Sets fine scanning mode (pm)	0
FSCF=n.nn	Sets fine scanning mode (GHz)	0
Smin=nnnn.nn	Sets lower scan wavelength limit (nm)	0
Smax=nnnn.nn	Sets upper scan wavelength limit (nm)	0
Step=nn.nnn	Sets scan step value (nm)	0
Stime=n.n	Sets scan step time (s)	0
I?	Requests present current level (mA) answer format : I=nn.n	0,4

**Table D-1: Summary of IEEE-488.1 control commands (Cont.)**

Command	Action	Set/clear status bits
P?	Requests present power output level answer format : P=nn.nn (mW unit active) answer format : P=±nn.nn (dBm unit active)	0,4
L?	Requests present emission wavelength (nm) answer format : L=nnnn.nnn	0,4
f?	Requests present emission frequency (GHz) answer format : f=nnnnnn.n	0,4
APCON	Switches system to constant power mode	0, 3
APCOFF	Switches system to constant current mode	0, 3
MW	Sets power unit to mW	0
DBM	Sets power unit to dBm	0
SCAN	Initiates scan  (At termination of scan)	0,3,7  0,7
STOP	Terminates scan in progress	0,7
*SRE=nnn	Sets automatic service request (SRQ) mask	0
GPAD=nn	Changes the GPIB address	0
ENABLE	Enables laser output	0
DISABLE	Disables laser output	0

Table D-2 lists the significance of each bit in the status word.

**Table D-2: Status word**

Bit number	Code name	Significance when bit = 1
7 (MSB)	SCANNING	Wavelength scan in progress.
6	SRQ	The tunable laser requests service from the bus controller.
5	(none)	(for future use)
4	MAV	The parameter value requested by the controller is now available for reading.
3	LIM	The laser current has reached its maximum upper limit (this occurs in the APC mode if the set power exceeds the tunable laser's capability at the wavelength of operation).
2	ERRV	The last value received from the controller is incorrectly formatted or is outside the accepted range.

**Table D-2: Status word (Cont.)**

Bit number	Code name	Significance when bit = 1
1	ERRC	The last command received from the controller is invalid.
0	OPC	The tunable laser has executed all received instructions, and the motor is at rest.



# Index

## Numbers

2ND key, 1–9

## A

accessories, standard, 1–2, 2–22  
advanced functions  
    accessing, 1–9  
    detailed, 1–15  
APC key, 1–8  
arrow keys, 1–8, 1–9

## B

backlash suppression, 1–17

## C

calibration, 2–18  
certifications, 1–38  
cleaning  
    exterior, 2–19  
    optical connectors, 2–17  
commands  
    GPIB, D–1  
    RS-232-C, C–1  
compliances, 1–38  
connectors  
    auxiliary, 1–18  
    cleaning and caring for, 2–17  
    laser output, 1–9, 1–38, 2–17  
    monitor, 1–18  
contacting Tektronix, vii  
controls  
    arrow keys, 1–11  
    backlash suppression, 1–11  
    control knob, 1–10, 1–11  
    keypad, 1–10  
    parameters, A–1  
current  
    monitor output, 1–13  
    selection, 1–8

## D

data  
    display, 1–7

    display selection, 1–8  
data entry, 1–10  
dimensions, 1–38

## E

editing data, 1–10  
ENABLE key, 1–8  
ENTER key, 1–9  
entering data, 1–10  
error messages, B–1

## F

f key, 1–8  
front panel, overview, 1–7  
FSC, input, 1–13  
FSC key, 1–8  
fuse  
    part number, 2–22  
    rating, 1–38  
    replacing, 2–19

## G

GPIB, 1–27  
    changing the address, 1–35  
    commands, D–1  
    conditions of use, 1–31  
    errors, 1–32  
    IEEE-488.1 standard, 1–31  
    lockout, 1–36  
    message synchronization, 1–31  
    operating commands, 1–28  
    operating mode commands, 1–30  
    parameters, 1–28  
    protocol, 1–28  
    queries, 1–28, 1–30  
    SRQ, 1–34  
    status word, 1–32  
        bits, 1–32  
        reading, 1–34

## H

HF modulation, input, 1–13  
humidity, specified, 1–38

**I**

- I key, 1–8
- IEEE-488.1. *See* GPIB
- IEEE-488.1 connector, 1–12
- index, modulation, 1–12
- inputs, 1–13
  - FSC, 1–12
- installation, 1–4
- instrument care
  - handling, 1–2
  - maintenance, 2–17
  - packaging for shipment, 2–20
  - unpacking, 1–2
- interface connection, RS-232-C, 1–21
- interface connector
  - GPIB, 1–12
  - RS-232-C, 1–12

**L**

- laser
  - connecting output, 1–4
  - enabling output, 1–8
  - enabling the output, 1–5, 1–9
  - features, 1–1
  - front panel location, 1–7
  - initializing, 1–5
  - shutting down, 1–5
- LF modulation, input, 1–13
- line frequency range, 1–38
- line fuse, 2–19
- linewidth, 1–37

**M**

- maintenance, 2–17
- mode, front panel selection, 1–7
- mode hop, spacing, 1–37
- mode keys, 1–8
- mode lock frequency, 1–38
- modulation
  - high frequency, 1–38
  - low frequency, 1–38
  - optical wavelength, 1–37
  - power, 1–20
  - tuning range, 1–37
- monitor outputs, 1–12
  - current, 1–18
  - power, 1–18
  - sync, 1–18
  - voltage scaling, 1–18

- wavelength, 1–18
- mW/dBm key, 1–8

**N**

- nm/GHz key, 1–8

**O**

- operation
  - APC, 1–11
  - backlash suppression, 1–17
  - entering numerical values, 1–10
  - first time, 1–4
  - front panel, 1–7
  - GPIB, 1–27
  - overview, 1–7
  - rear panel, 1–12
  - remote, 1–8, 1–21
  - RS-232-C, 1–21
  - setup for, 1–4
- options, 1–3
- output fiber, specified, 1–38
- output power, 1–37
- outputs
  - analog, 1–12
  - coherence control, 1–12
  - motor sync, 1–12
  - TTL, 1–12

**P**

- P key, 1–8
- parts
  - replaceable, 2–21
  - standard accessories, 2–22
- performance verification, 2–1
  - absolute wavelength accuracy, 2–3
  - equipment required, 2–1
  - output power, 2–4
  - preparation, 2–2
  - wavelength range, 2–4
- power
  - APC, 1–11
  - calibration, 1–17
  - front panel key, 1–7
  - monitor output, 1–13
  - output, 2–4
  - selection, 1–8
- power cord options, 2–22
- power stability, 1–37

## R

- rear panel, overview, 1–12
- remote control, specified, 1–38
- Remote interlock, 1–13
- remote interlock, 1–19
- REMOTE key, 1–8
- return loss, 1–37
- RIN, 1–37
- RS-232-C, 1–21
  - command parameters, 1–24
  - command responses, 1–25
  - commands, C–1
  - connector, 1–12
  - example commands, 1–22
  - format of numerics, 1–23
  - message format, 1–22
  - operating mode, 1–25
  - queries, 1–26
  - response messages, 1–23
  - system commands, 1–27

## S

- safety
  - first time operation, 1–4
  - general summary, v
  - handling, 1–2
  - symbols and terms, vi
- scroll message, 1–9
- setup, front panel entry, 1–7
- setup keys, 1–8
- SMSR, 1–37

- specifications, 1–37
- STEP key, 1–9
- sync
  - monitor output, 1–12
  - motor, 1–12

## T

- Tektronix, how to contact, vii
- temperature, specified, 1–38
- tuning
  - repeatability, 1–37
  - speed, 1–37
  - wavelength modulation range, 1–37

## V

- voltage and power consumption, 1–38

## W

- wavelength
  - absolute accuracy, 1–37, 2–3
  - calibration, 1–16
  - coherence control, 1–19
  - fine tuning, 1–19
  - monitor output, 1–12
  - range, 1–37, 2–4
  - scanning, 1–15
  - selection, 1–8
  - setting resolution, 1–37
- weight, 1–38







