

**PRELIMINARY**  
 Notice: This is not a final specification.  
 Some parametric limits are subject to  
 change.

# MITSUBISHI MICROCOMPUTERS 4513/4514 Group

SINGLE-CHIP 4-BIT CMOS MICROCOMPUTER

## DESCRIPTION

The 4513/4514 Group is a 4-bit single-chip microcomputer designed with CMOS technology. Its CPU is that of the 4500 series using a simple, high-speed instruction set. The computer is equipped with serial I/O, four 8-bit timers (each timer has a reload register), and 10-bit A-D converter.

The various microcomputers in the 4513/4514 Group include variations of the built-in memory type and package as shown in the table below.

## FEATURES

- Minimum instruction execution time ..... 0.75  $\mu$ s  
 (at 4.0 MHz oscillation frequency, in high-speed mode, V<sub>DD</sub> = 4.0 V to 5.5 V)
- Supply voltage
  - Middle-speed mode
    - ..... 2.5 V to 5.5 V (at 4.2 MHz oscillation frequency, for Mask ROM version and One Time PROM version)
    - ..... 2.0 V to 5.5 V (at 3.0 MHz oscillation frequency, for Mask ROM version)
    - (Operation voltage of A-D conversion: 2.7 V to 5.5 V)
  - High-speed mode
    - ..... 4.0 V to 5.5 V (at 4.2 MHz oscillation frequency, for Mask ROM version and One Time PROM version)
    - ..... 2.5 V to 5.5 V (at 2.0 MHz oscillation frequency, for Mask ROM version and One Time PROM version)
    - ..... 2.0 V to 5.5 V (at 1.5 MHz oscillation frequency, for Mask ROM version)
    - (Operation voltage of A-D conversion: 2.7 V to 5.5 V)

- Timers
  - Timer 1 ..... 8-bit timer with a reload register
  - Timer 2 ..... 8-bit timer with a reload register
  - Timer 3 ..... 8-bit timer with a reload register
  - Timer 4 ..... 8-bit timer with a reload register
- Interrupt ..... 8 sources
- Serial I/O ..... 8 bit-wide
- A-D converter ..... 10-bit successive comparison method
- Voltage comparator ..... 2 circuits
- Watchdog timer ..... 16 bits
- Voltage drop detection circuit
- Clock generating circuit (ceramic resonator)
- LED drive directly enabled (port D)

## APPLICATION

Microwave oven, rice cooker, audio, telephone, office equipment

Product	ROM (PROM) size (X 10 bits)	RAM size (X 4 bits)	Package	ROM type
M34513M2-XXXSP/FP *	2048 words	128 words	SP: 32P4B FP: 32P6B-A	Mask ROM
M34513M4-XXXSP/FP *	4096 words	256 words	SP: 32P4B FP: 32P6B-A	Mask ROM
M34513E4SP/FP * (Note)	4096 words	256 words	SP: 32P4B FP: 32P6B-A	One Time PROM
M34513M6-XXXFP **	6144 words	384 words	32P6B-A	Mask ROM
M34513M8-XXXFP **	8192 words	384 words	32P6B-A	Mask ROM
M34513E8FP ** (Note)	8192 words	384 words	32P6B-A	One Time PROM
M34514M6-XXXFP *	6144 words	384 words	42P2R-A	Mask ROM
M34514M8-XXXFP *	8192 words	384 words	42P2R-A	Mask ROM
M34514E8FP * (Note)	8192 words	384 words	42P2R-A	One Time PROM

Note: shipped in blank  
 \*: Under development  
 \*\*: Under planning

**PIN CONFIGURATION (TOP VIEW) 4513 Group**

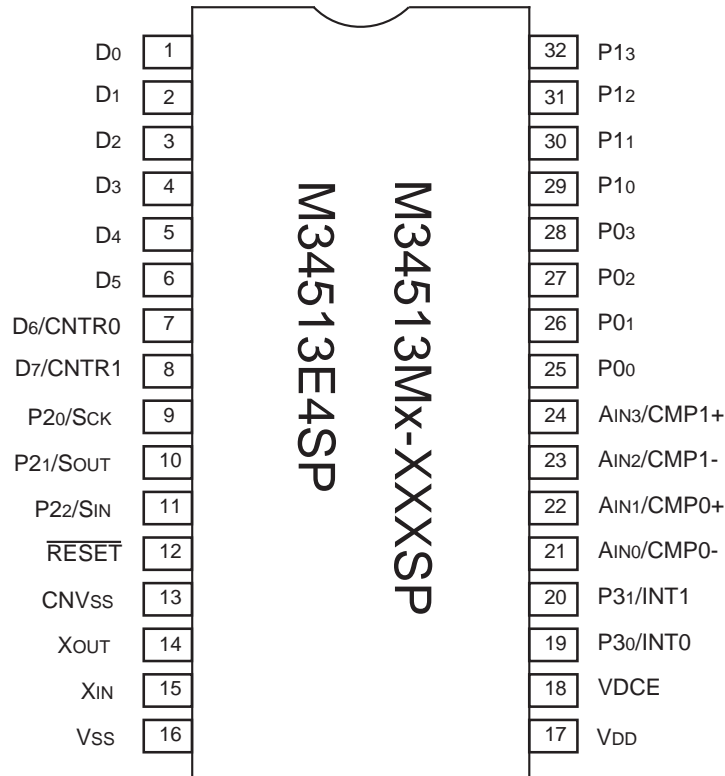

Outline 32P4B

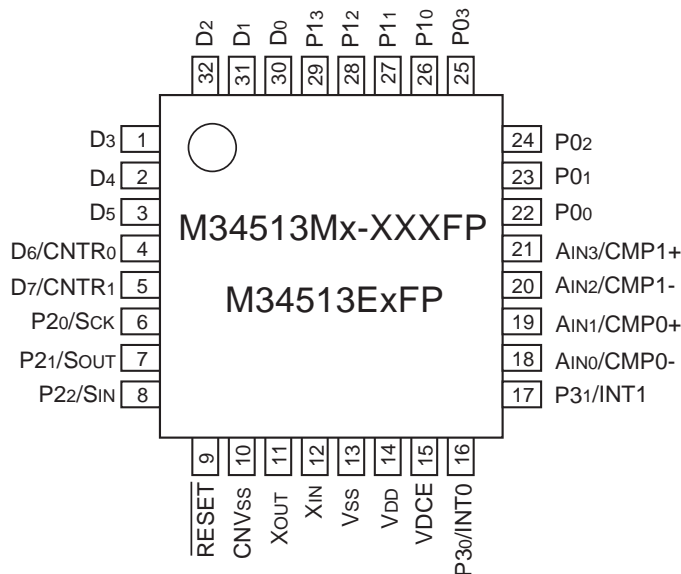

Outline 32P6B-A

**PRELIMINARY**  
 Notice: This is not a final specification.  
 Some parametric limits are subject to  
 change.

**PIN CONFIGURATION (TOP VIEW) 4514 Group**

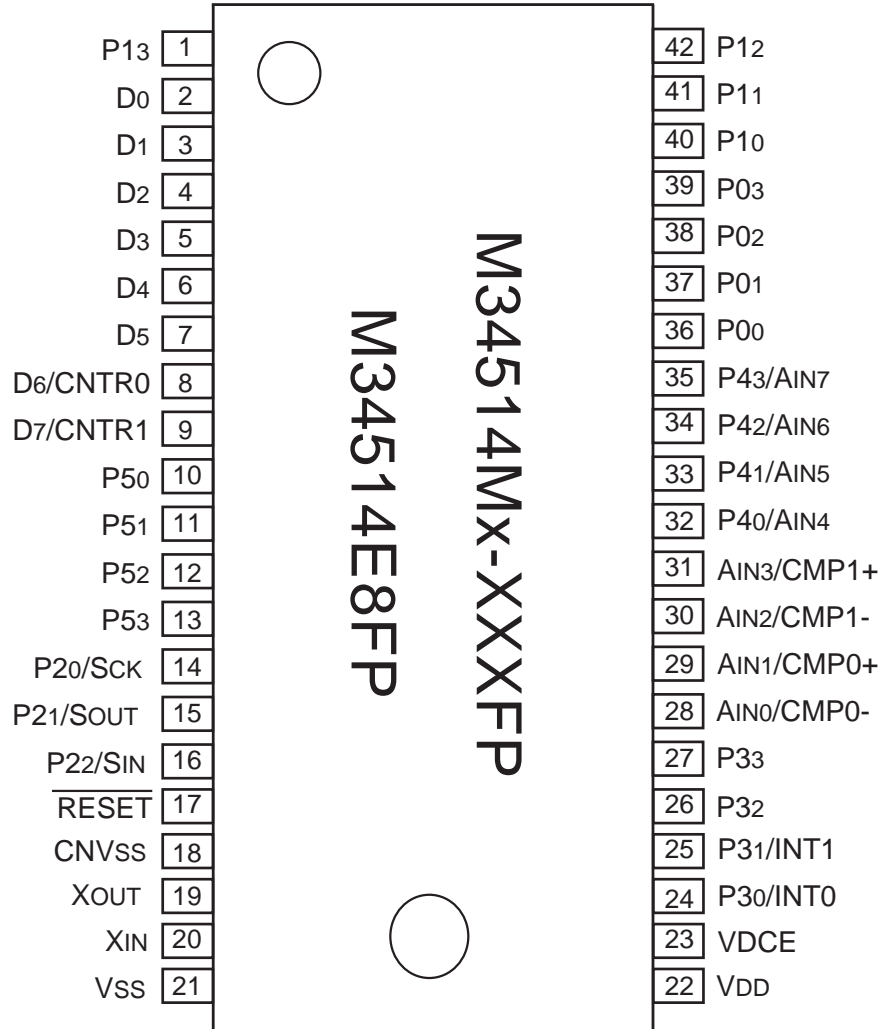

Outline 42P2R-A

**BLOCK DIAGRAM (4513 Group)**

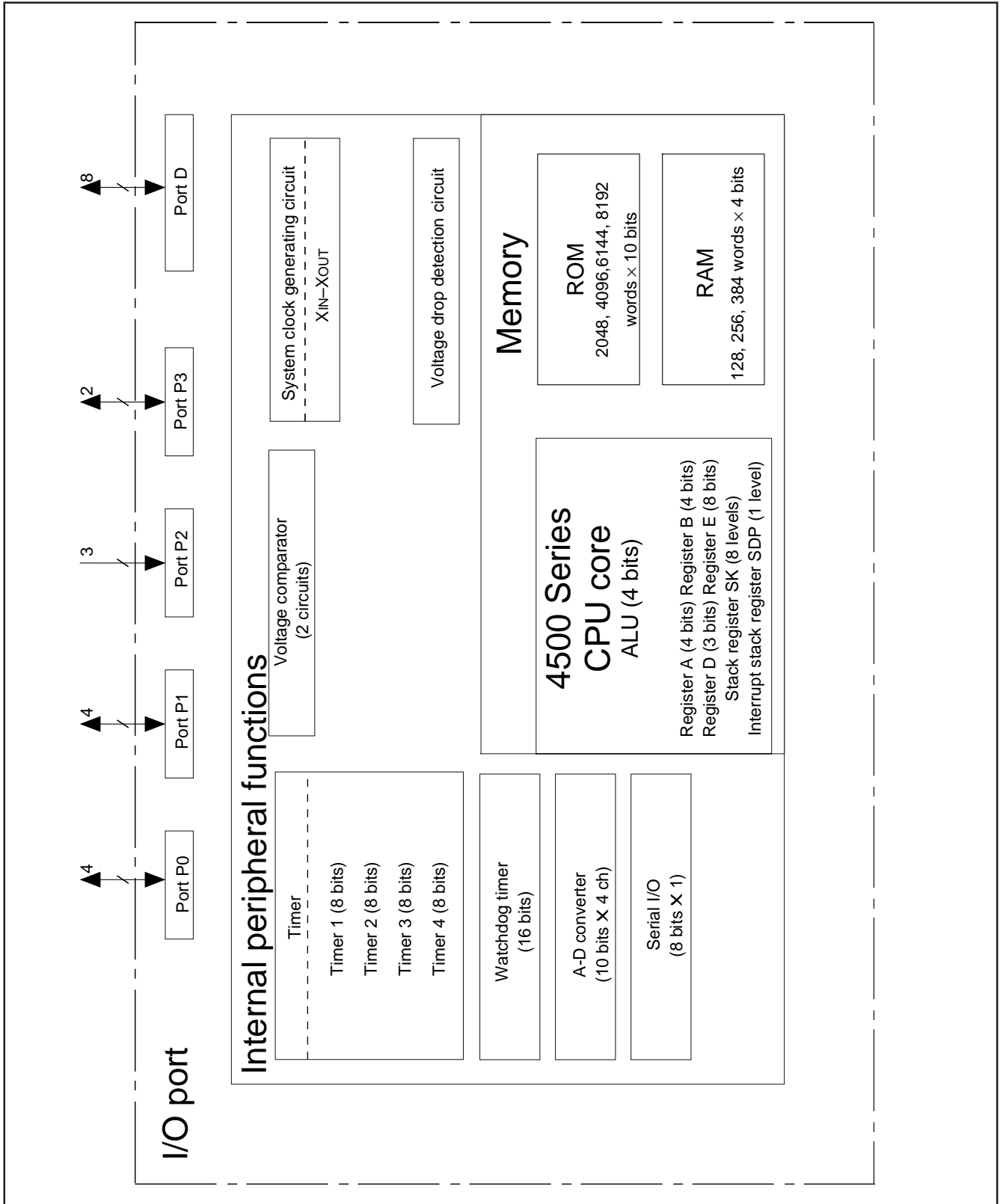

**PRELIMINARY**  
 Notice: This is not a final specification.  
 Some parametric limits are subject to  
 change.

**BLOCK DIAGRAM (4514 Group)**

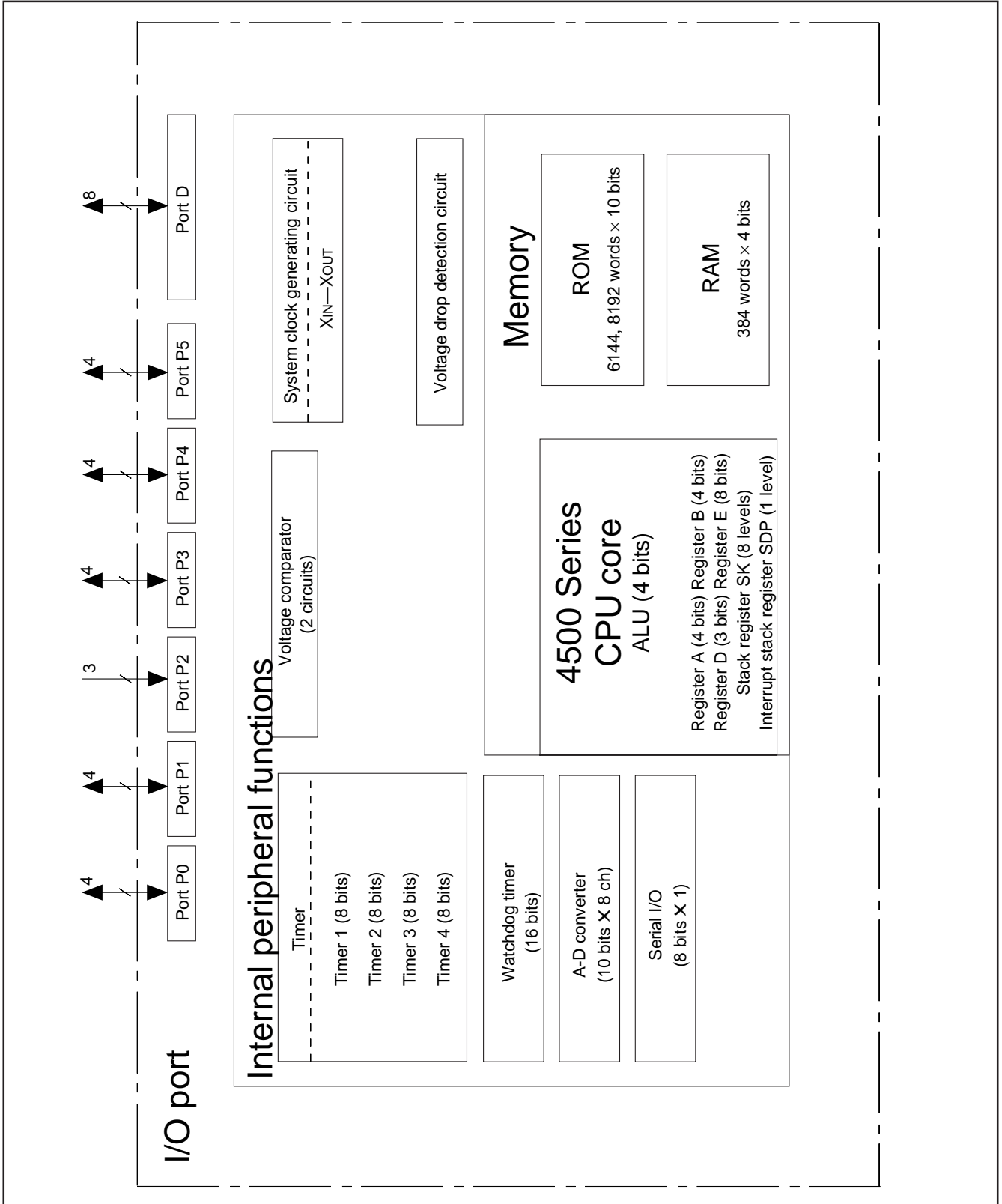

**PRELIMINARY**  
 Notice: This is not a final specification.  
 Some parametric limits are subject to  
 change.

## PERFORMANCE OVERVIEW

Parameter		Function	
Number of basic instructions	4513 Group	123	
	4514 Group	128	
Minimum instruction execution time		0.75 $\mu$ s (at 4.0 MHz oscillation frequency, in high-speed mode)	
Memory sizes	ROM	M34513M2	2048 words $\times$ 10 bits
		M34513M4/E4	4096 words $\times$ 10 bits
		M34513M6	6144 words $\times$ 10 bits
		M34513M8/E8	8192 words $\times$ 10 bits
		M34514M6	6144 words $\times$ 10 bits
		M34514M8/E8	8192 words $\times$ 10 bits
	RAM	M34513M2	128 words $\times$ 4 bits
		M34513M4/E4	256 words $\times$ 4 bits
		M34513M6	384 words $\times$ 4 bits
		M34513M8/E8	384 words $\times$ 4 bits
		M34514M6	384 words $\times$ 4 bits
		M34514M8/E8	384 words $\times$ 4 bits
Input/Output ports	D0–D7	I/O (Input is examined by skip decision)	Eight independent I/O ports; ports D6 and D7 are also used as CNTR0 and CNTR1, respectively.
	P00–P03	I/O	4-bit I/O port; each pin is equipped with a pull-up function and a key-on wakeup function. Both functions can be switched by software.
	P10–P13	I/O	4-bit I/O port; each pin is equipped with a pull-up function and a key-on wakeup function. Both functions can be switched by software.
	P20–P22	Input	3-bit input port; ports P20, P21 and P22 are also used as SCK, SOUT and SIN, respectively.
	P30–P33	I/O	4-bit I/O port (2-bit I/O port for the 4513 Group); ports P30 and P31 are also used as INT0 and INT1, respectively. The 4513 Group does not have ports P32, P33.
	P40–P43	I/O	4-bit I/O port; The 4513 Group does not have this port.
	P50–P53	I/O	4-bit I/O port with a direction register; The 4513 Group does not have this port.
	CNTR0	I/O	1-bit I/O; CNTR0 pin is also used as port D6.
	CNTR1	I/O	1-bit I/O; CNTR1 pin is also used as port D7.
	INT0	Input	1-bit input; INT0 pin is also used as port P30 and equipped with a key-on wakeup function.
	INT1	Input	1-bit input; INT1 pin is also used as port P31 and equipped with a key-on wakeup function.
Timers	Timer 1		8-bit programmable timer with a reload register.
	Timer 2		8-bit programmable timer with a reload register is also used as an event counter.
	Timer 3		8-bit programmable timer with a reload register.
	Timer 4		8-bit programmable timer with a reload register is also used as an event counter.
A-D converter		10-bit wide, This is equipped with an 8-bit comparator function.	
Voltage comparator		2 circuits (CMP0, CMP1)	
Serial I/O		8-bit $\times$ 1	
Interrupt	Sources		8 (two for external, four for timer, one for A-D, and one for serial I/O)
	Nesting		1 level
Subroutine nesting			8 levels
Device structure			CMOS silicon gate
Package	4513 Group		32-pin plastic molded SDIP (32P4B)/LQFP(32P6B-A)
	4514 Group		42-pin plastic molded SSOP (42P2R-A)
Operating temperature range			–20 °C to 85 °C
Supply voltage			2.0 V to 5.5 V for Mask ROM version, 2.5 V to 5.5 V for One Time PROM version (Refer to the electrical characteristics because the supply voltage depends on the oscillation frequency.)
Power dissipation (typical value)	Active mode		1.8 mA (at V <sub>DD</sub> = 5.0 V, 4.0 MHz oscillation frequency, in middle-speed mode, output transistors in the cut-off state)
			3.0 mA (at V <sub>DD</sub> = 5.0 V, 4.0 MHz oscillation frequency, in high-speed mode, output transistors in the cut-off state)
	RAM back-up mode		0.1 $\mu$ A (at room temperature, V <sub>DD</sub> = 5 V, output transistors in the cut-off state)

**PRELIMINARY**  
 Notice: This is not a final specification.  
 Some parametric limits are subject to  
 change.

## PIN DESCRIPTION

Pin	Name	Input/Output	Function
VDD	Power supply	—	Connected to a plus power supply.
VSS	Ground	—	Connected to a 0 V power supply.
VDCE	Voltage drop detection circuit enable	Input	VDCE pin is used to control the operation/stop of the voltage drop detection circuit. When "H" level is input to this pin, the circuit is operating. When "L" level is input to this pin, the circuit is stopped.
CNVSS	CNVSS	—	Connect CNVSS to VSS and apply "L" (0V) to CNVSS certainly.
RESET	Reset input	I/O	An N-channel open-drain I/O pin for a system reset. When the watchdog timer causes the system to be reset or system reset is performed by the voltage drop detection circuit, the RESET pin outputs "L" level.
XIN	System clock input	Input	I/O pins of the system clock generating circuit. XIN and XOUT can be connected to ceramic resonator. A feedback resistor is built-in between them.
XOUT	System clock output	Output	
D0–D7	I/O port D (Input is examined by skip decision.)	I/O	Each pin of port D has an independent 1-bit wide I/O function. Each pin has an output latch. For input use, set the latch of the specified bit to "1." The output structure is N-channel open-drain. Ports D6 and D7 are also used as CNTR0 and CNTR1, respectively.
P00–P03	I/O port P0	I/O	Each of ports P0 and P1 serves as a 4-bit I/O port, and it can be used as inputs when the output latch is set to "1." The output structure is N-channel open-drain. Every pin of the ports has a key-on wakeup function and a pull-up function. Both functions can be switched by software.
P10–P13	I/O port P1	I/O	
P20–P22	Input port P2	Input	3-bit input port. Ports P20, P21 and P22 are also used as SCK, SOUT and SIN, respectively.
P30–P33	I/O port P3	I/O	4-bit I/O port (2-bit I/O port for the 4513 Group). For input use, set the latch of the specified bit to "1." The output structure is N-channel open-drain. Ports P30 and P31 are also used as INT0 and INT1, respectively. The 4513 Group does not have ports P32, P33.
P40–P43	I/O port P4	I/O	4-bit I/O port. For input use, set the latch of the specified bit to "1." The output structure is N-channel open-drain. Ports P40–P43 are also used as analog input pins AIN4–AIN7, respectively. The 4513 Group does not have port P4.
P50–P53	I/O port P5	I/O	4-bit I/O port. Each pin has a direction register and an independent 1-bit wide I/O function. For input use, set the direction register to "0." For output use, set the direction register to "1." The output structure is CMOS. The 4513 Group does not have port P5.
AIN0–AIN7	Analog input	Input	Analog input pins for A-D converter. AIN0–AIN3 are also used as comparator input pins and AIN4–AIN7 are also used as port P4. The 4513 Group does not have AIN4–AIN7.
CNTR0	Timer input/output	I/O	CNTR0 pin has the function to input the clock for the timer 2 event counter, and to output the timer 1 underflow signal divided by 2. CNTR0 pin is also used as port D6.
CNTR1	Timer input/output	I/O	CNTR1 pin has the function to input the clock for the timer 4 event counter, and to output the timer 3 underflow signal divided by 2. CNTR1 pin is also used as port D7.
INT0, INT1	Interrupt input	Input	INT0, INT1 pins accept external interrupts. They also accept the input signal to return the system from the RAM back-up state. INT0, INT1 pins are also used as ports P30 and P31, respectively.
SIN	Serial data input	Input	SIN pin is used to input serial data signals by software. SIN pin is also used as port P22.
SOUT	Serial data output	Output	SOUT pin is used to output serial data signals by software. SOUT pin is also used as port P21.
SCK	Serial I/O clock input/output	I/O	SCK pin is used to input and output synchronous clock signals for serial data transfer by software. SCK pin is also used as port P20.
CMP0- CMP0+	Voltage comparator input	Input	CMP0-, CMP0+ pins are used as the voltage comparator input pin when the voltage comparator function is selected by software. CMP0-, CMP0+ pins are also used as AIN0 and AIN1.
CMP1- CMP1+	Voltage comparator input	Input	CMP1-, CMP1+ pins are used as the voltage comparator input pin when the voltage comparator function is selected by software. CMP1-, CMP1+ pins are also used as AIN2 and AIN3.

**PRELIMINARY**  
 Notice: This is not a final specification.  
 Some parametric limits are subject to change.

**MULTIFUNCTION**

Pin	Multifunction	Pin	Multifunction	Pin	Multifunction	Pin	Multifunction
D6	CNTR0	CNTR0	D6	AIN0	CMP0-	CMP0-	AIN0
D7	CNTR1	CNTR1	D7	AIN1	CMP0+	CMP0+	AIN1
P20	SCK	SCK	P20	AIN2	CMP1-	CMP1-	AIN2
P21	SOUT	SOUT	P21	AIN3	CMP1+	CMP1+	AIN3
P22	SIN	SIN	P22	P40	AIN4	AIN4	P40
P30	INT0	INT0	P30	P41	AIN5	AIN5	P41
P31	INT1	INT1	P31	P42	AIN6	AIN6	P42
				P43	AIN7	AIN7	P43

- Notes 1: Pins except above have just single function.  
 2: The input of D6, D7, P20–P22, CMP0-, CMP0+, CMP1-, CMP1+ and the input/output of P30, P31, P40–P43 can be used even when CNTR0, CNTR1, SCK, SOUT, SIN, INT0, INT1, and AIN0–AIN7 are selected.  
 3: The 4513 Group does not have P40/AIN4–P43/AIN7.

**CONNECTIONS OF UNUSED PINS**

Pin	Connection
XOUT	Open (when using an external clock).
VDCE	Connect to Vss.
D0–D5 D6/CNTR0 D7/CNTR1	Connect to Vss, or set the output latch to "0" and open.
P20/SCK P21/SOUT P22/SIN	Connect to Vss.
P30/INT0 P31/INT1 P32, P33	Connect to Vss, or set the output latch to "0" and open.
P40/AIN4–P43/AIN7	Connect to Vss, or set the output latch to "0" and open.
P50–P53 (Note 1)	When the input mode is selected by software, pull-up to VDD through a resistor or pull-down to VDD. When selecting the output mode, open.
AIN0/CMP0- AIN1/CMP0+ AIN2/CMP1- AIN3/CMP1+	Connect to Vss.
P00–P03	Open or connect to Vss (Note 2)
P10–P13	Open or connect to Vss (Note 2)

- Notes 1: After system is released from reset, port P5 is in a input mode (direction register FR0 = 00002)  
 2: When the P00–P03 and P10–P13 are connected to Vss, turn off their pull-up transistors (register PU0i="0") and also invalidate the key-on wakeup functions (register K0i="0") by software. When these pins are connected to Vss while the key-on wakeup functions are left valid, the system fails to return from RAM back-up state. When these pins are open, turn on their pull-up transistors (register PU0i="1") by software, or set the output latch to "0." Be sure to select the key-on wakeup functions and the pull-up functions with every two pins. If only one of the two pins for the key-on wakeup function is used, turn on their pull-up transistors by software and also disconnect the other pin. (i = 0, 1, 2, or 3.)
- (Note when the output latch is set to "0" and pins are open)  
 ● After system is released from reset, port is in a high-impedance state until it is set the output latch to "0" by software. Accordingly, the voltage level of pins is undefined and the excess of the supply current may occur while the port is in a high-impedance state.  
 ● To set the output latch periodically by software is recommended because value of output latch may change by noise or a program run away (caused by noise).
- (Note when connecting to Vss and VDD)  
 ● Connect the unused pins to Vss and VDD using the thickest wire at the shortest distance against noise.



**PRELIMINARY**  
 Notice: This is not a final specification.  
 Some parametric limits are subject to  
 change.

**PORT FUNCTION**

Port	Pin	Input Output	Output structure	I/O unit	Control instructions	Control registers	Remark
Port D	D0–D5	I/O (8)	N-channel open-drain	1	SD, RD SZD CLD	W6	
	D6/CNTR0						
	D7/CNTR1						
Port P0	P00–P03	I/O (4)	N-channel open-drain	4	OP0A IAP0	PU0, K0	Built-in programmable pull-up functions Key-on wakeup functions (programmable)
Port P1	P10–P13	I/O (4)	N-channel open-drain	4	OP1A IAP1	PU0, K0	Built-in programmable pull-up functions Key-on wakeup functions (programmable)
Port P2	P20/SCK P21/SOUT P22/SIN	Input (3)		3	IAP2	J1	
Port P3 (Note 1)	P30/INT0 P31/INT1 P32, P33	I/O (4)	N-channel open-drain	4	OP3A IAP3	I1, I2	Built-in key-on wakeup function (P30/INT0, P31/INT1)
Port P4 (Note 2)	P40/AIN4 –P43/AIN7	I/O (4)	N-channel open-drain	4	OP4A IAP4	Q2	
Port P5 (Note 2)	P50–P53	I/O (4)	CMOS	4	OP5A IAP5	FR0	

Notes 1: The 4513 Group does not have P32 and P33.  
 2: The 4513 Group does not have these ports.

**DEFINITION OF CLOCK AND CYCLE**

- System clock  
 The system clock is the basic clock for controlling this product.  
 The system clock is selected by the bit 3 of the clock control register MR.

**Table Selection of system clock**

Register MR MR3	System clock
0	f(XIN)
1	f(XIN)/2

Note: f(XIN)/2 is selected after system is released from reset.

- Instruction clock  
 The instruction clock is a signal derived by dividing the system clock by 3. The one instruction clock cycle generates the one machine cycle.
- Machine cycle  
 The machine cycle is the standard cycle required to execute the instruction.

**PRELIMINARY**  
 Notice: This is not a final specification.  
 Some parametric limits are subject to  
 change.

**PORT BLOCK DIAGRAMS**

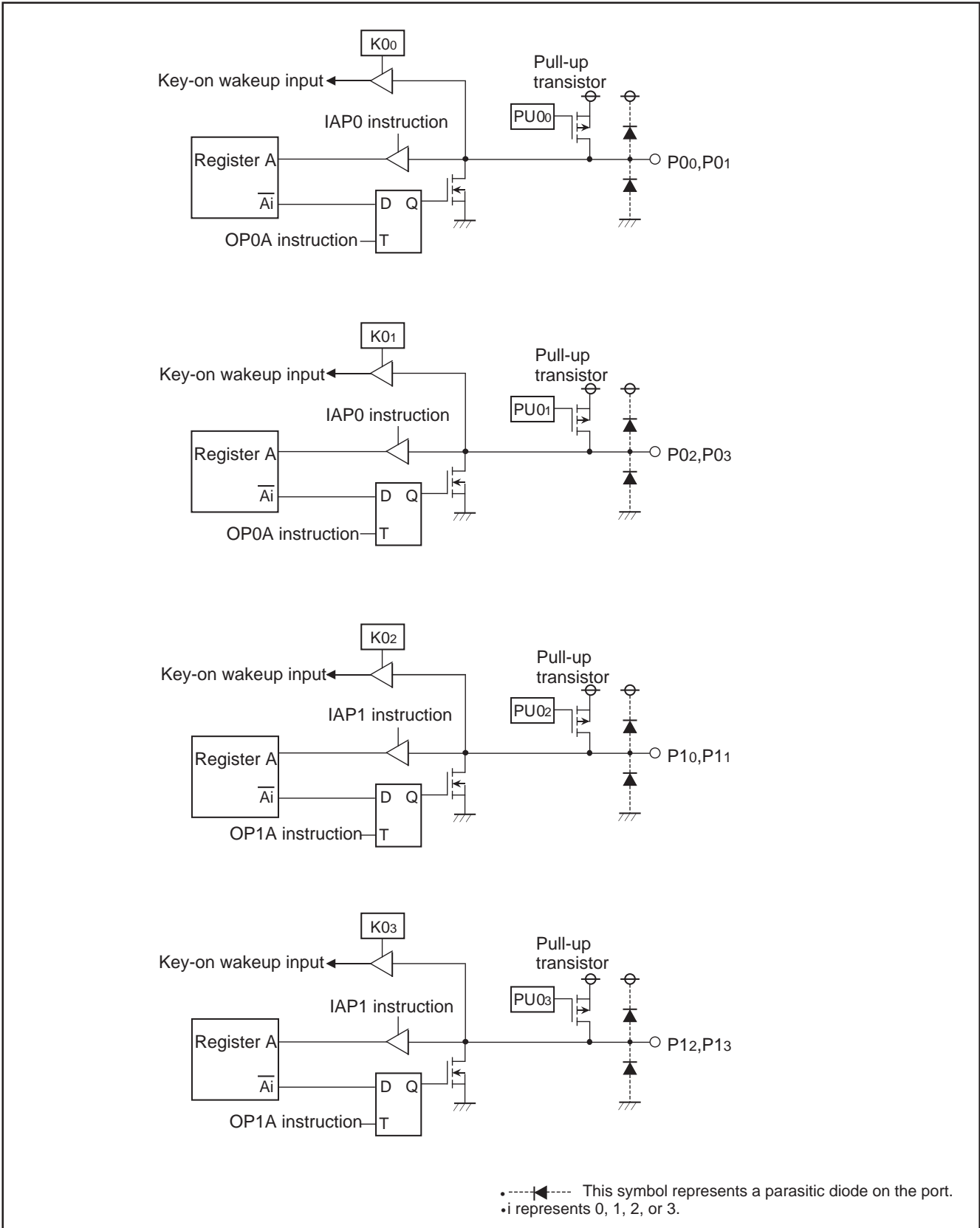

**PORT BLOCK DIAGRAMS (continued)**

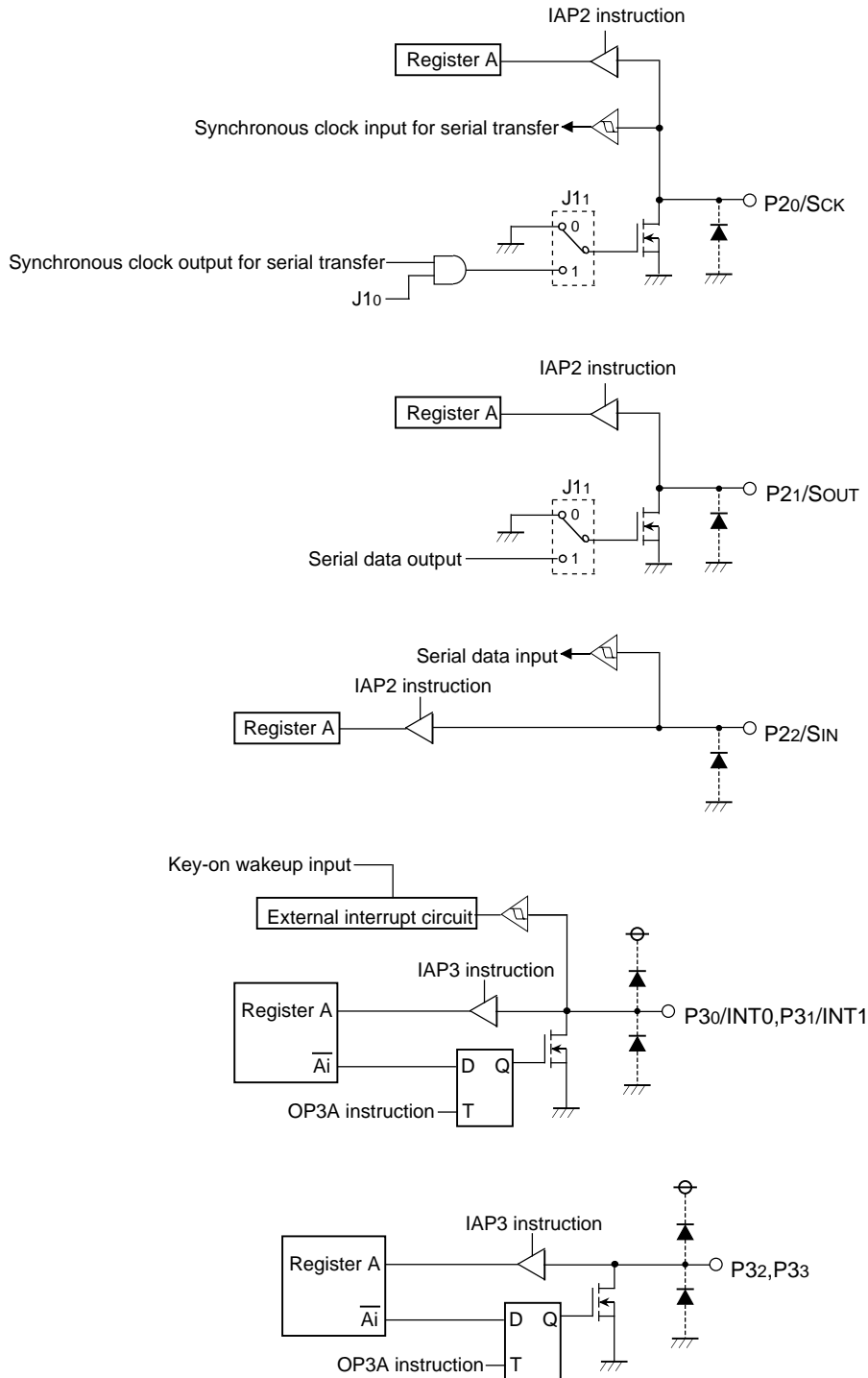

- This symbol represents a parasitic diode on the port.
- Applied potential to ports P20—P22 must be V<sub>DD</sub>.
- i represents 0, 1, 2, or 3.
- The 4513 Group does not have ports P32, P33.

**PORT BLOCK DIAGRAMS (continued)**

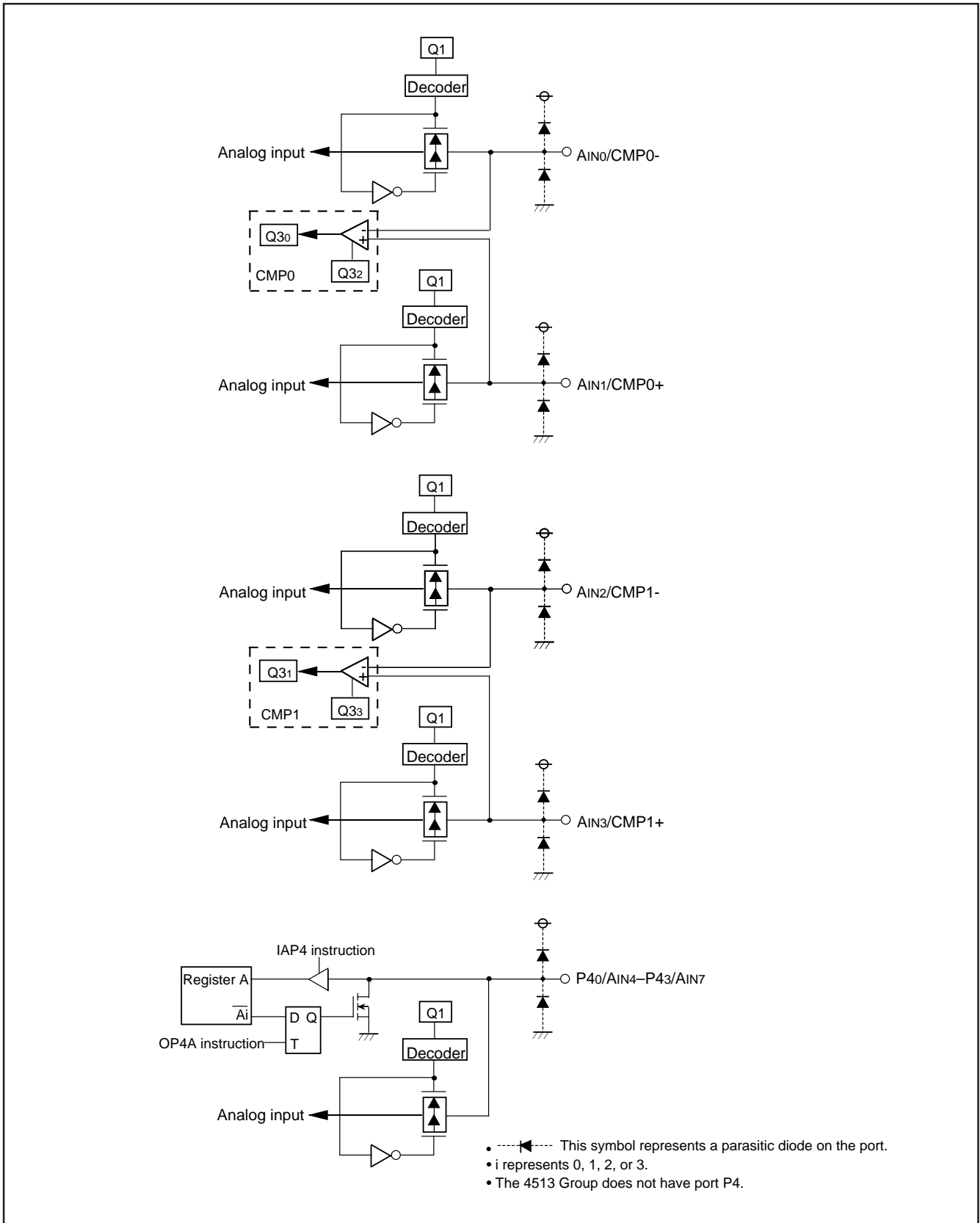

**PORT BLOCK DIAGRAMS (continued)**

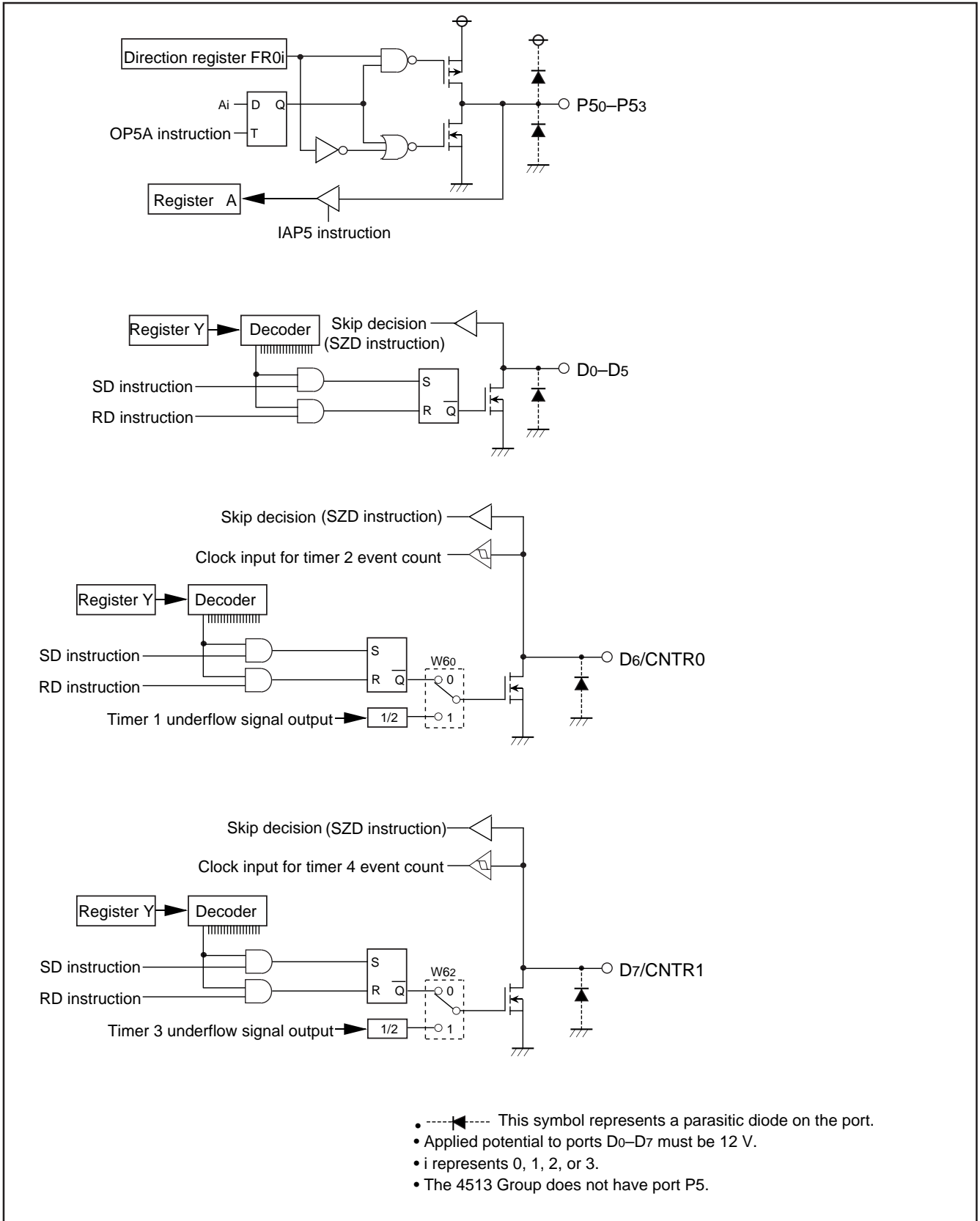

**PRELIMINARY**  
Notice: This is not a final specification.  
Some parametric limits are subject to  
change.

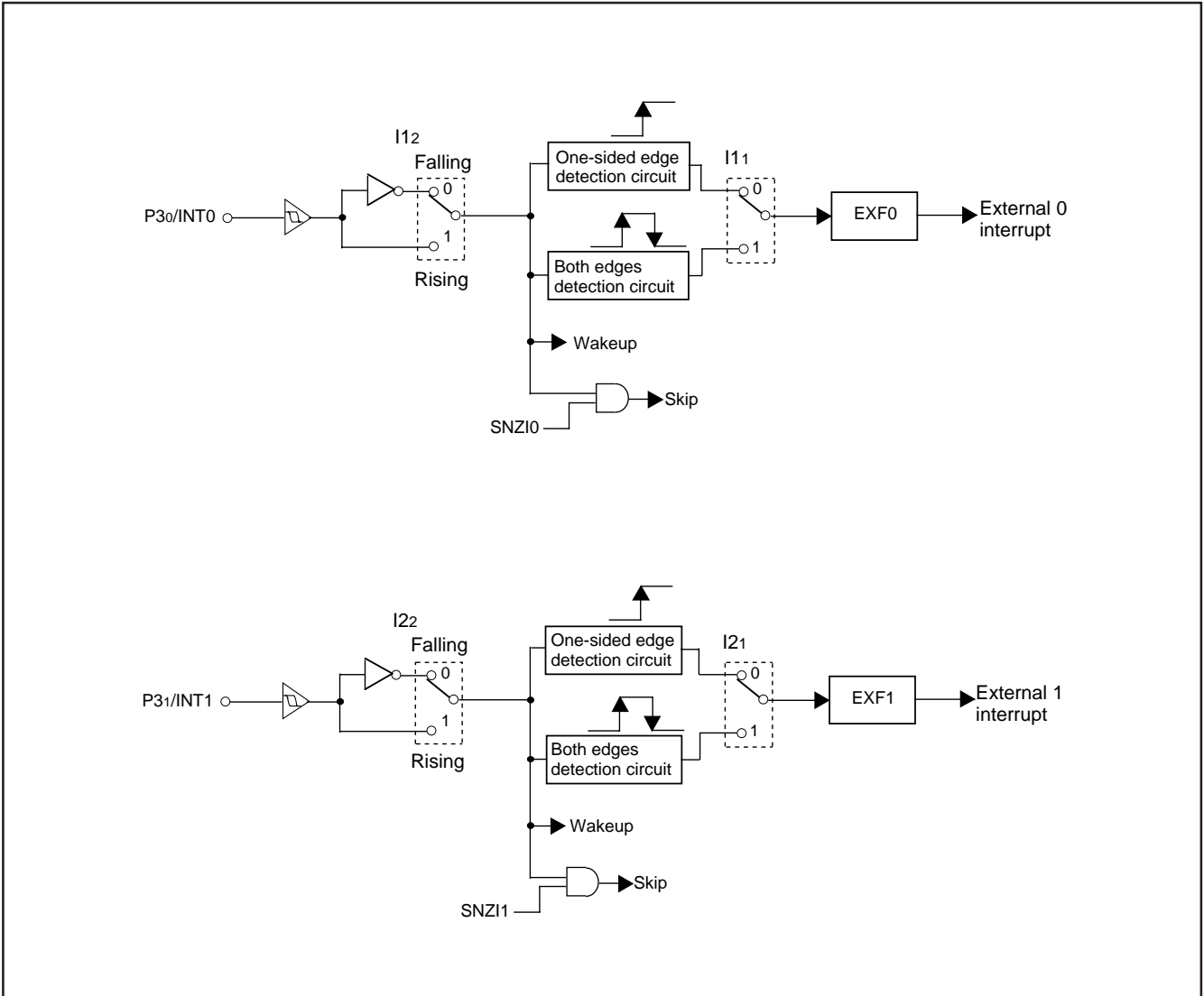

External interrupt circuit structure

**PRELIMINARY**  
 Notice: This is not a final specification.  
 Some parametric limits are subject to  
 change.

**FUNCTION BLOCK OPERATIONS  
 CPU**

**(1) Arithmetic logic unit (ALU)**

The arithmetic logic unit ALU performs 4-bit arithmetic such as 4-bit data addition, comparison, AND operation, OR operation, and bit manipulation.

**(2) Register A and carry flag**

Register A is a 4-bit register used for arithmetic, transfer, exchange, and I/O operation.

Carry flag CY is a 1-bit flag that is set to "1" when there is a carry with the AMC instruction (Figure 1).

It is unchanged with both A n instruction and AM instruction. The value of A0 is stored in carry flag CY with the RAR instruction (Figure 2).

Carry flag CY can be set to "1" with the SC instruction and cleared to "0" with the RC instruction.

**(3) Registers B and E**

Register B is a 4-bit register used for temporary storage of 4-bit data, and for 8-bit data transfer together with register A.

Register E is an 8-bit register. It can be used for 8-bit data transfer with register B used as the high-order 4 bits and register A as the low-order 4 bits (Figure 3).

**(4) Register D**

Register D is a 3-bit register.

It is used to store a 7-bit ROM address together with register A and is used as a pointer within the specified page when the TABP p, BLA p, or BMLA p instruction is executed (Figure 4).

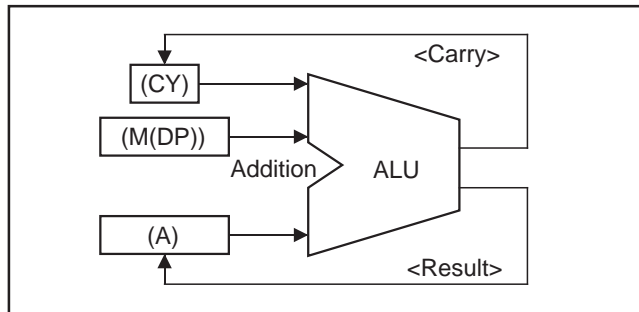

Fig. 1 AMC instruction execution example

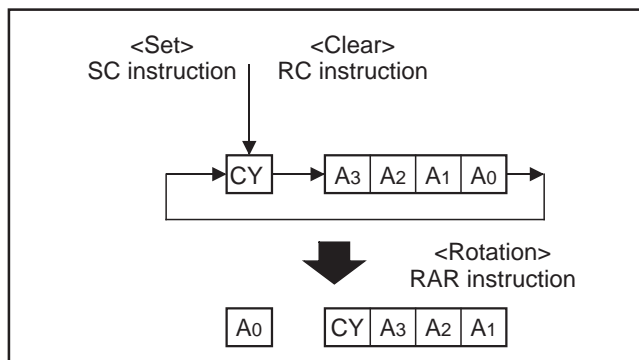

Fig. 2 RAR instruction execution example

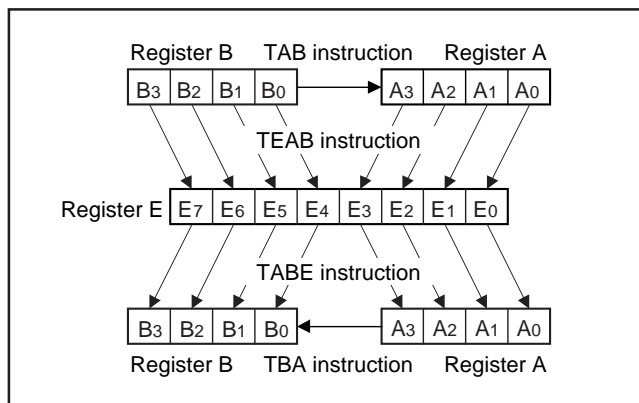

Fig. 3 Registers A, B and register E

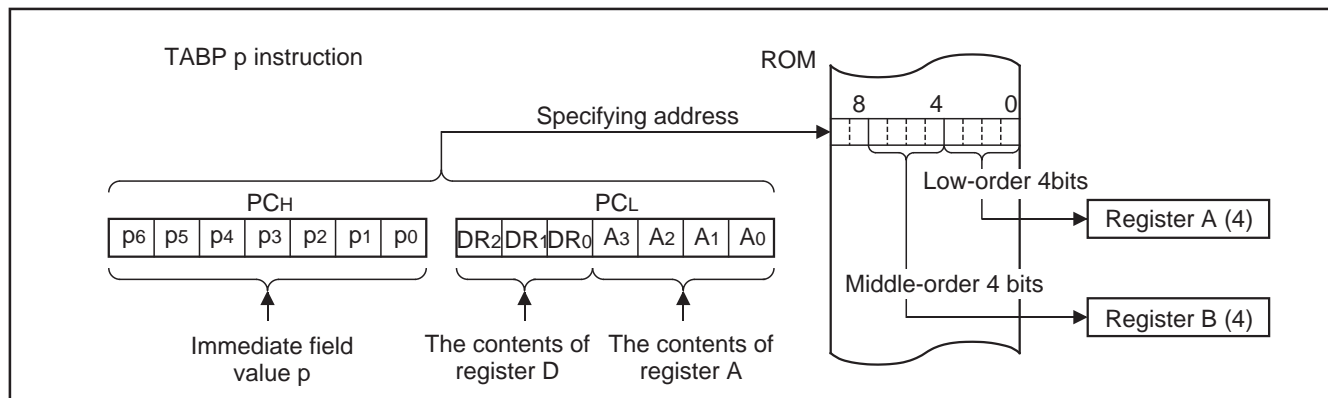

Fig. 4 TABP p instruction execution example

**PRELIMINARY**  
 Notice: This is not a final specification.  
 Some parametric limits are subject to change.

**(5) Stack registers (SKs) and stack pointer (SP)**

Stack registers (SKs) are used to temporarily store the contents of program counter (PC) just before branching until returning to the original routine when;

- branching to an interrupt service routine (referred to as an interrupt service routine),
- performing a subroutine call, or
- executing the table reference instruction (TABP).

Stack registers (SKs) are eight identical registers, so that subroutines can be nested up to 8 levels. However, one of stack registers is used respectively when using an interrupt service routine and when executing a table reference instruction. Accordingly, be careful not to over the stack when performing these operations together. The contents of registers SKs are destroyed when 8 levels are exceeded.

The register SK nesting level is pointed automatically by 3-bit stack pointer (SP). The contents of the stack pointer (SP) can be transferred to register A with the TASP instruction.

Figure 5 shows the stack registers (SKs) structure.

Figure 6 shows the example of operation at subroutine call.

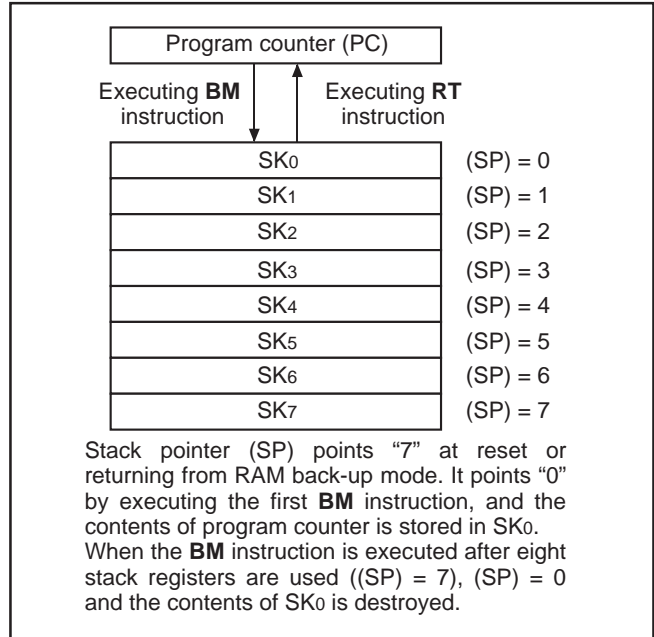

Fig. 5 Stack registers (SKs) structure

**(6) Interrupt stack register (SDP)**

Interrupt stack register (SDP) is a 1-stage register. When an interrupt occurs, this register (SDP) is used to temporarily store the contents of data pointer, carry flag, skip flag, register A, and register B just before an interrupt until returning to the original routine.

Unlike the stack registers (SKs), this register (SDP) is not used when executing the subroutine call instruction and the table reference instruction.

**(7) Skip flag**

Skip flag controls skip decision for the conditional skip instructions and continuous described skip instructions. When an interrupt occurs, the contents of skip flag is stored automatically in the interrupt stack register (SDP) and the skip condition is retained.

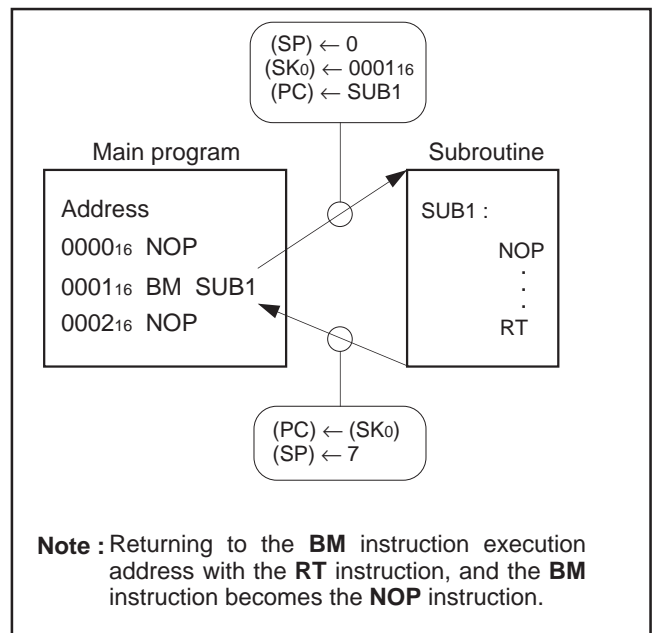

Fig. 6 Example of operation at subroutine call



**PRELIMINARY**  
 Notice: This is not a final specification.  
 Some parametric limits are subject to change.

**(8) Program counter (PC)**

Program counter (PC) is used to specify a ROM address (page and address). It determines a sequence in which instructions stored in ROM are read. It is a binary counter that increments the number of instruction bytes each time an instruction is executed. However, the value changes to a specified address when branch instructions, subroutine call instructions, return instructions, or the table reference instruction (TABP p) is executed.

Program counter consists of PCH (most significant bit to bit 7) which specifies to a ROM page and PCL (bits 6 to 0) which specifies an address within a page. After it reaches the last address (address 127) of a page, it specifies address 0 of the next page (Figure 7).

Make sure that the PCH does not specify after the last page of the built-in ROM.

**(9) Data pointer (DP)**

Data pointer (DP) is used to specify a RAM address and consists of registers Z, X, and Y. Register Z specifies a RAM file group, register X specifies a file, and register Y specifies a RAM digit (Figure 8).

Register Y is also used to specify the port D bit position. When using port D, set the port D bit position to register Y certainly and execute the SD, RD, or SZD instruction (Figure 9).

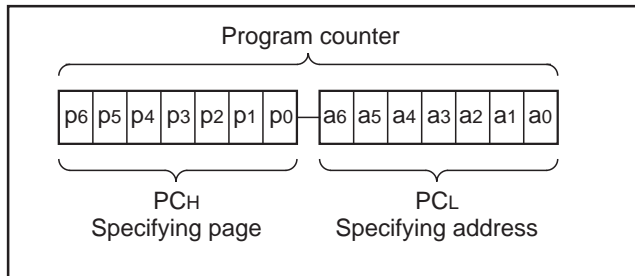

Fig. 7 Program counter (PC) structure

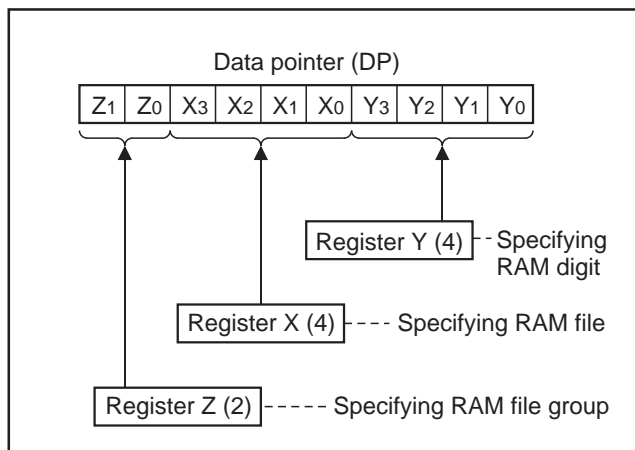

Fig. 8 Data pointer (DP) structure

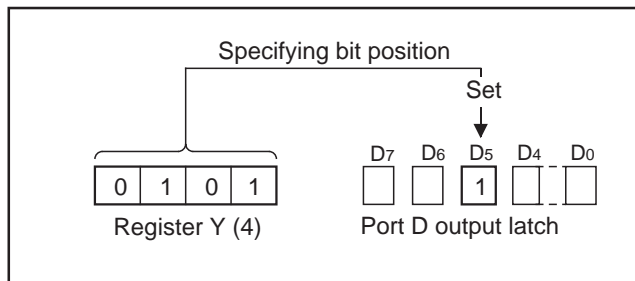

Fig. 9 SD instruction execution example

**PRELIMINARY**  
 Notice: This is not a final specification.  
 Some parametric limits are subject to change.

**PROGRAM MEMORY (ROM)**

The program memory is a mask ROM. 1 word of ROM is composed of 10 bits. ROM is separated every 128 words by the unit of page (addresses 0 to 127). Table 1 shows the ROM size and pages. Figure 10 shows the ROM map of M34514M8/E8.

**Table 1 ROM size and pages**

Product	ROM size (X 10 bits)	Pages
M34513M2	2048 words	16 (0 to 15)
M34513M4/E4	4096 words	32 (0 to 31)
M34513M6	6144 words	48 (0 to 47)
M34513M8/E8	8192 words	64 (0 to 63)
M34514M6	6144 words	48 (0 to 47)
M34514M8/E8	8192 words	64 (0 to 63)

A part of page 1 (addresses 0080<sub>16</sub> to 00FF<sub>16</sub>) is reserved for interrupt addresses (Figure 11). When an interrupt occurs, the address (interrupt address) corresponding to each interrupt is set in the program counter, and the instruction at the interrupt address is executed. When using an interrupt service routine, write the instruction generating the branch to that routine at an interrupt address.

Page 2 (addresses 0100<sub>16</sub> to 017F<sub>16</sub>) is the special page for subroutine calls. Subroutines written in this page can be called from any page with the 1-word instruction (BM). Subroutines extending from page 2 to another page can also be called with the BM instruction when it starts on page 2.

ROM pattern (bits 7 to 0) of all addresses can be used as data areas with the TABP p instruction.

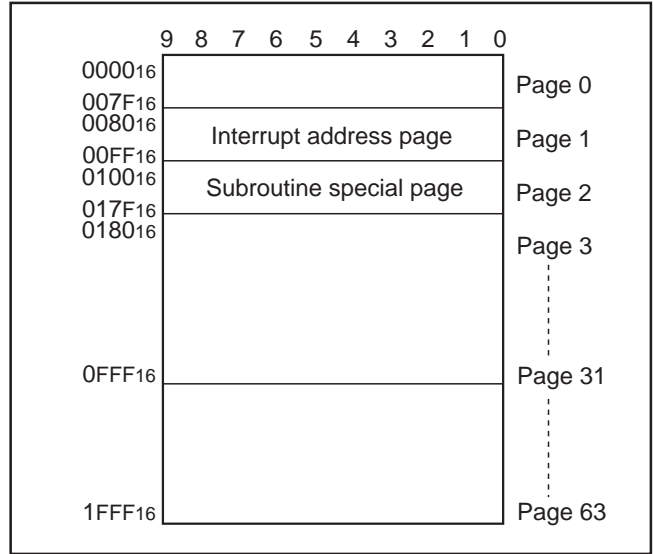

**Fig. 10 ROM map of M34514M8/E8**

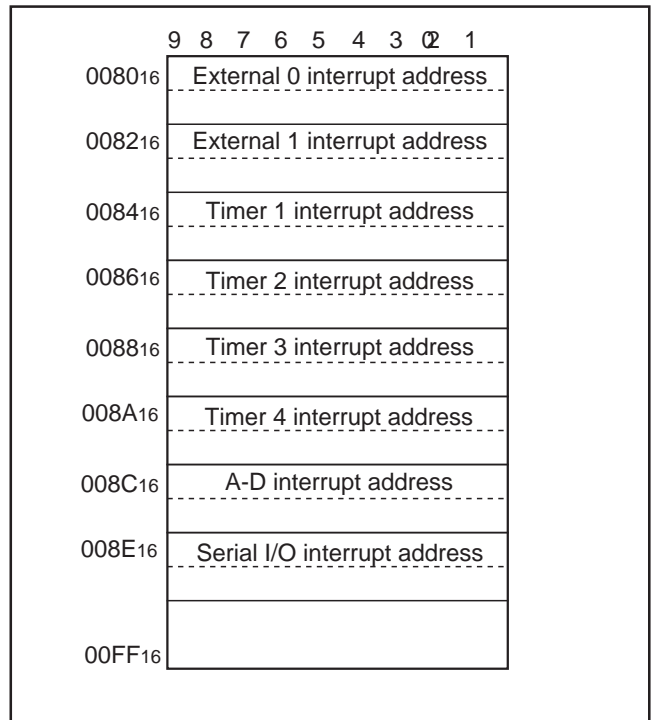

**Fig. 11 Page 1 (addresses 0080<sub>16</sub> to 00FF<sub>16</sub>) structure**

**PRELIMINARY**  
 Notice: This is not a final specification.  
 Some parametric limits are subject to change.

**DATA MEMORY (RAM)**

1 word of RAM is composed of 4 bits, but 1-bit manipulation (with the SB j, RB j, and SZB j instructions) is enabled for the entire memory area. A RAM address is specified by a data pointer. The data pointer consists of registers Z, X, and Y. Set a value to the data pointer certainly when executing an instruction to access RAM.

Table 2 shows the RAM size. Figure 12 shows the RAM map.

**Table 2 RAM size**

Product	RAM size
M34513M2	128 words X 4 bits (512 bits)
M34513M4/E4	256 words X 4 bits (1024 bits)
M34513M6	384 words X 4 bits (1536 bits)
M34513M8/E8	384 words X 4 bits (1536 bits)
M34514M6	384 words X 4 bits (1536 bits)
M34514M8/E8	384 words X 4 bits (1536 bits)

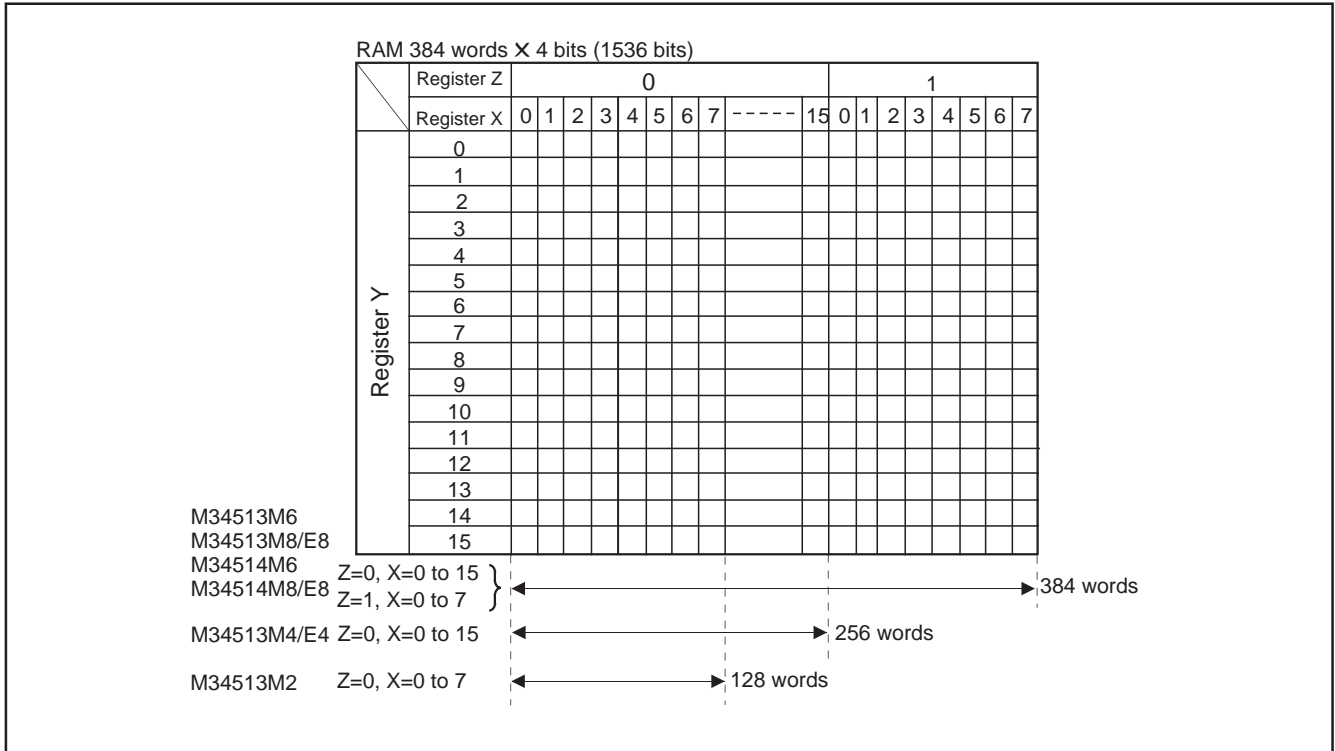

Fig. 12 RAM map

**PRELIMINARY**  
 Notice: This is not a final specification.  
 Some parametric limits are subject to  
 change.

**INTERRUPT FUNCTION**

The interrupt type is a vectored interrupt branching to an individual address (interrupt address) according to each interrupt source. An interrupt occurs when the following 3 conditions are satisfied.

- An interrupt activated condition is satisfied (request flag = "1")
- Interrupt enable bit is enabled ("1")
- Interrupt enable flag is enabled (INTE = "1")

Table 3 shows interrupt sources. (Refer to each interrupt request flag for details of activated conditions.)

**(1) Interrupt enable flag (INTE)**

The interrupt enable flag (INTE) controls whether the every interrupt enable/disable. Interrupts are enabled when INTE flag is set to "1" with the EI instruction and disabled when INTE flag is cleared to "0" with the DI instruction. When any interrupt occurs, the INTE flag is automatically cleared to "0," so that other interrupts are disabled until the EI instruction is executed.

**(2) Interrupt enable bit**

Use an interrupt enable bit of interrupt control registers V1 and V2 to select the corresponding interrupt or skip instruction.

Table 4 shows the interrupt request flag, interrupt enable bit and skip instruction.

Table 5 shows the interrupt enable bit function.

**(3) Interrupt request flag**

When the activated condition for each interrupt is satisfied, the corresponding interrupt request flag is set to "1." Each interrupt request flag is cleared to "0" when either;

- an interrupt occurs, or
- the next instruction is skipped with a skip instruction.

Each interrupt request flag is set when the activated condition is satisfied even if the interrupt is disabled by the INTE flag or its interrupt enable bit. Once set, the interrupt request flag retains set until a clear condition is satisfied.

Accordingly, an interrupt occurs when the interrupt disable state is released while the interrupt request flag is set.

If more than one interrupt request flag is set when the interrupt disable state is released, the interrupt priority level is as follows shown in Table 3.

**Table 3 Interrupt sources**

Priority level	Interrupt name	Activated condition	Interrupt address
1	External 0 interrupt	Level change of INT0 pin	Address 0 in page 1
2	External 1 interrupt	Level change of INT1 pin	Address 2 in page 1
3	Timer 1 interrupt	Timer 1 underflow	Address 4 in page 1
4	Timer 2 interrupt	Timer 2 underflow	Address 6 in page 1
5	Timer 3 interrupt	Timer 3 underflow	Address 8 in page 1
6	Timer 4 interrupt	Timer 4 underflow	Address A in page 1
7	A-D interrupt	Completion of A-D conversion	Address C in page 1
8	Serial I/O interrupt	Completion of serial I/O transfer	Address E in page 1

**Table 4 Interrupt request flag, interrupt enable bit and skip instruction**

Interrupt name	Request flag	Skip instruction	Enable bit
External 0 interrupt	EXF0	SNZ0	V10
External 1 interrupt	EXF1	SNZ1	V11
Timer 1 interrupt	T1F	SNZT1	V12
Timer 2 interrupt	T2F	SNZT2	V13
Timer 3 interrupt	T3F	SNZT3	V20
Timer 4 interrupt	T4F	SNZT4	V21
A-D interrupt	ADF	SNZAD	V22
Serial I/O interrupt	SIOF	SNZSI	V23

**Table 5 Interrupt enable bit function**

Interrupt enable bit	Occurrence of interrupt	Skip instruction
1	Enabled	Invalid
0	Disabled	Valid

**(4) Internal state during an interrupt**

The internal state of the microcomputer during an interrupt is as follows (Figure 14).

- Program counter (PC)  
 An interrupt address is set in program counter. The address to be executed when returning to the main routine is automatically stored in the stack register (SK).
- Interrupt enable flag (INTE)  
 INTE flag is cleared to "0" so that interrupts are disabled.
- Interrupt request flag  
 Only the request flag for the current interrupt source is cleared to "0."
- Data pointer, carry flag, skip flag, registers A and B  
 The contents of these registers and flags are stored automatically in the interrupt stack register (SDP).

**(5) Interrupt processing**

When an interrupt occurs, a program at an interrupt address is executed after branching a data store sequence to stack register. Write the branch instruction to an interrupt service routine at an interrupt address.

Use the RTI instruction to return from an interrupt service routine. Interrupt enabled by executing the EI instruction is performed after executing 1 instruction (just after the next instruction is executed). Accordingly, when the EI instruction is executed just before the RTI instruction, interrupts are enabled after returning the main routine. (Refer to Figure 13)

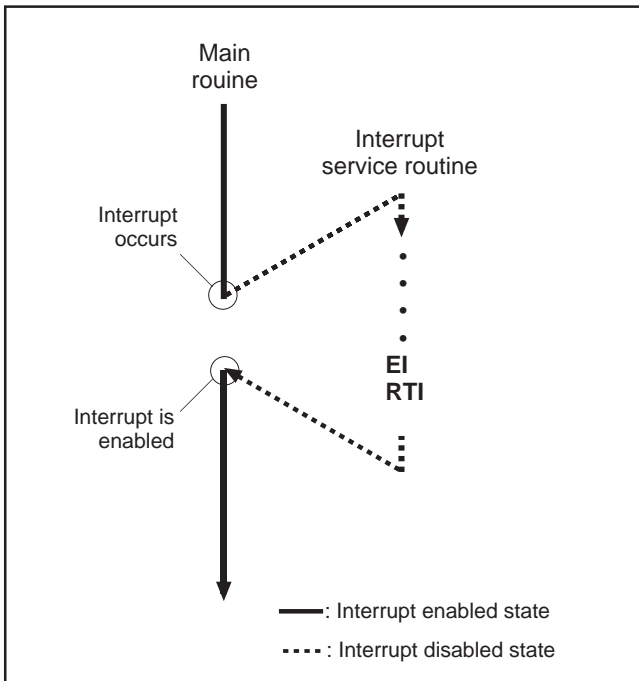

Fig. 13 Program example of interrupt processing

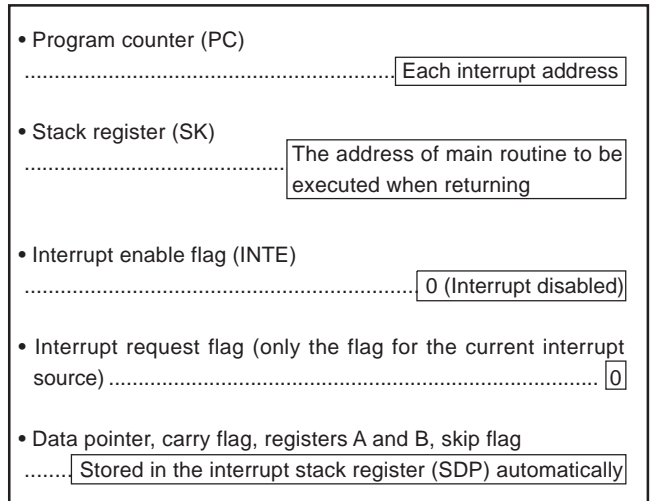

Fig. 14 Internal state when interrupt occurs

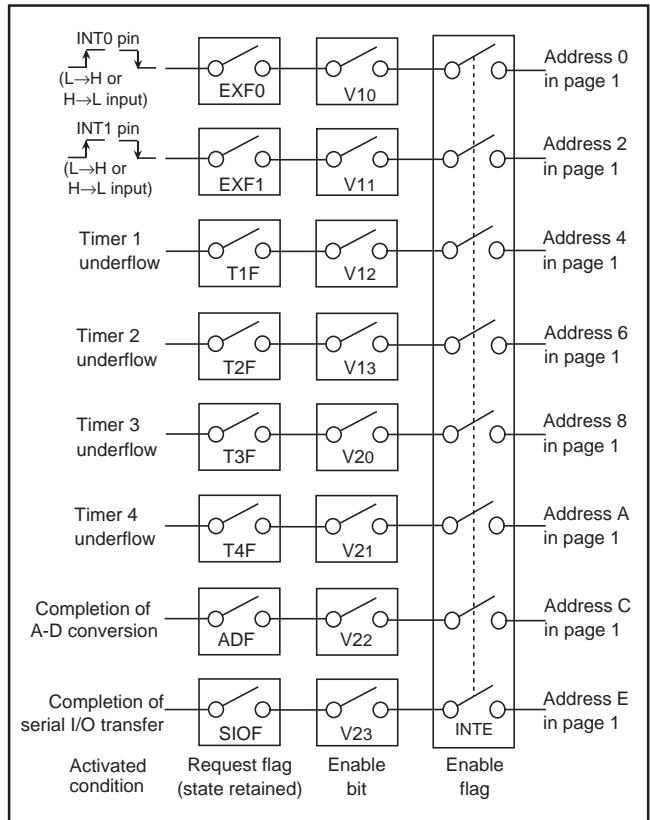

Fig. 15 Interrupt system diagram

**PRELIMINARY**  
 Notice: This is not a final specification.  
 Some parametric limits are subject to  
 change.

**(6) Interrupt control registers**

- Interrupt control register V1

Interrupt enable bits of external 0, external 1, timer 1 and timer 2 are assigned to register V1. Set the contents of this register through register A with the TV1A instruction. The TAV1 instruction can be used to transfer the contents of register V1 to register A.

- Interrupt control register V2

Interrupt enable bits of timer 3, timer 4, A-D and serial I/O are assigned to register V2. Set the contents of this register through register A with the TV2A instruction. The TAV2 instruction can be used to transfer the contents of register V2 to register A.

**Table 6 Interrupt control registers**

Interrupt control register V1		at reset : 00002		at RAM back-up : 00002		R/W
V13	Timer 2 interrupt enable bit	0	Interrupt disabled (SNZT2 instruction is valid)			
		1	Interrupt enabled (SNZT2 instruction is invalid)			
V12	Timer 1 interrupt enable bit	0	Interrupt disabled (SNZT1 instruction is valid)			
		1	Interrupt enabled (SNZT1 instruction is invalid)			
V11	External 1 interrupt enable bit	0	Interrupt disabled (SNZ1 instruction is valid)			
		1	Interrupt enabled (SNZ1 instruction is invalid)			
V10	External 0 interrupt enable bit	0	Interrupt disabled (SNZ0 instruction is valid)			
		1	Interrupt enabled (SNZ0 instruction is invalid)			
Interrupt control register V2		at reset : 00002		at RAM back-up : 00002		R/W
V23	Serial I/O interrupt enable bit	0	Interrupt disabled (SNZSI instruction is valid)			
		1	Interrupt enabled (SNZSI instruction is invalid)			
V22	A-D interrupt enable bit	0	Interrupt disabled (SNZAD instruction is valid)			
		1	Interrupt enabled (SNZAD instruction is invalid)			
V21	Timer 4 interrupt enable bit	0	Interrupt disabled (SNZT4 instruction is valid)			
		1	Interrupt enabled (SNZT4 instruction is invalid)			
V20	Timer 3 interrupt enable bit	0	Interrupt disabled (SNZT3 instruction is valid)			
		1	Interrupt enabled (SNZT3 instruction is invalid)			

Note: "R" represents read enabled, and "W" represents write enabled.

**(7) Interrupt sequence**

Interrupts only occur when the respective INTE flag, interrupt enable bits (V10–V13 and V20–V23), and interrupt request flag are "1." The interrupt actually occurs 2 to 3 machine cycles after the cycle in which all three conditions are satisfied. The interrupt oc-

curs after 3 machine cycles only when the three interrupt conditions are satisfied on execution of other than one-cycle instructions (Refer to Figure 16).

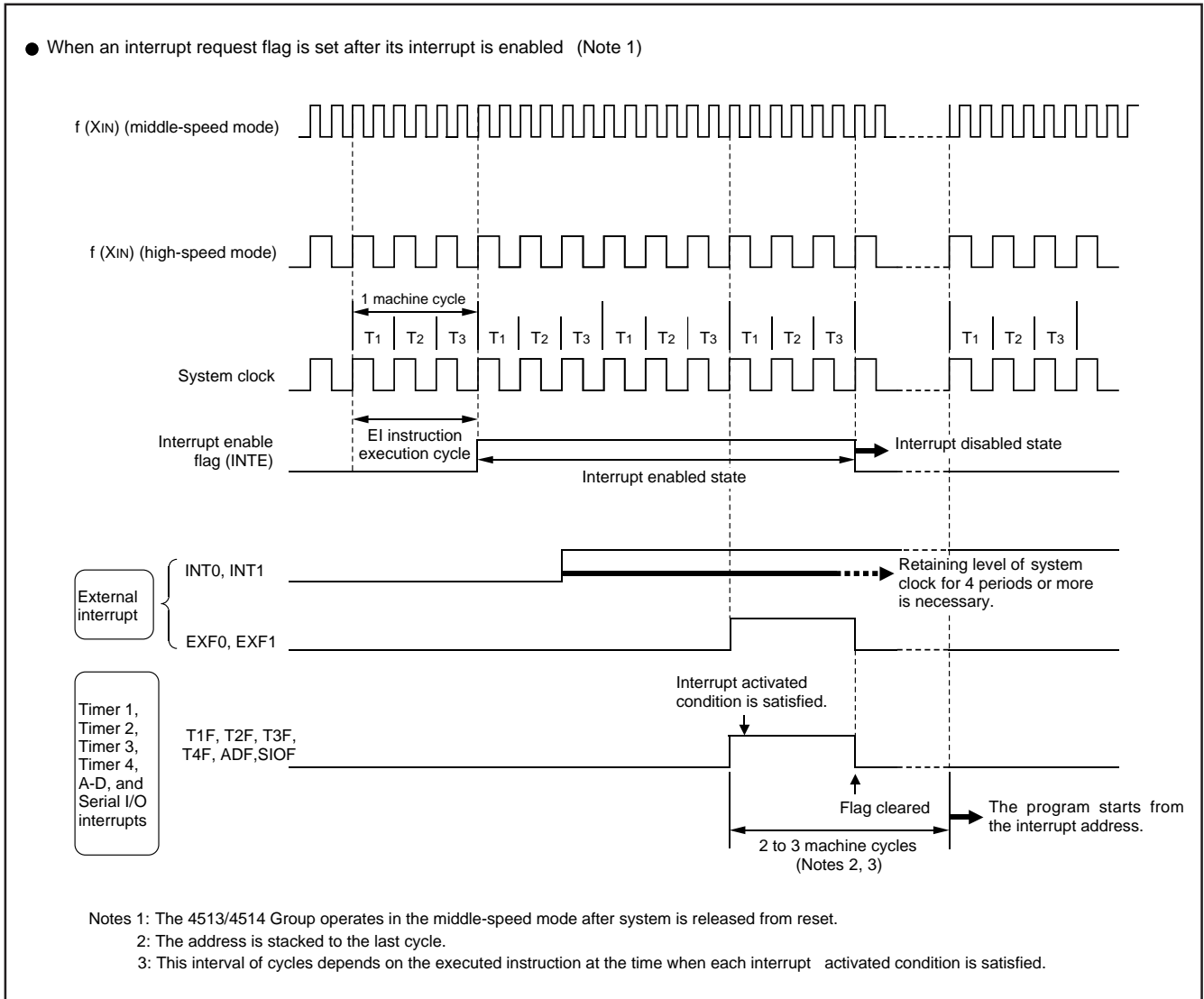

Fig. 16 Interrupt sequence

**EXTERNAL INTERRUPTS**

The 4513/4514 Group has two external interrupts (external 0 and external 1). An external interrupt request occurs when a valid waveform is input to an interrupt input pin (edge detection). The external interrupts can be controlled with the interrupt control registers I1 and I2.

**Table 7 External interrupt activated conditions**

Name	Input pin	Activated condition	Valid waveform selection bit
External 0 interrupt	P30/INT0	When the next waveform is input to P30/INT0 pin <ul style="list-style-type: none"> <li>• Falling waveform ("H"→"L")</li> <li>• Rising waveform ("L"→"H")</li> <li>• Both rising and falling waveforms</li> </ul>	I11 I12
External 1 interrupt	P31/INT1	When the next waveform is input to P31/INT1 pin <ul style="list-style-type: none"> <li>• Falling waveform ("H"→"L")</li> <li>• Rising waveform ("L"→"H")</li> <li>• Both rising and falling waveforms</li> </ul>	I21 I22

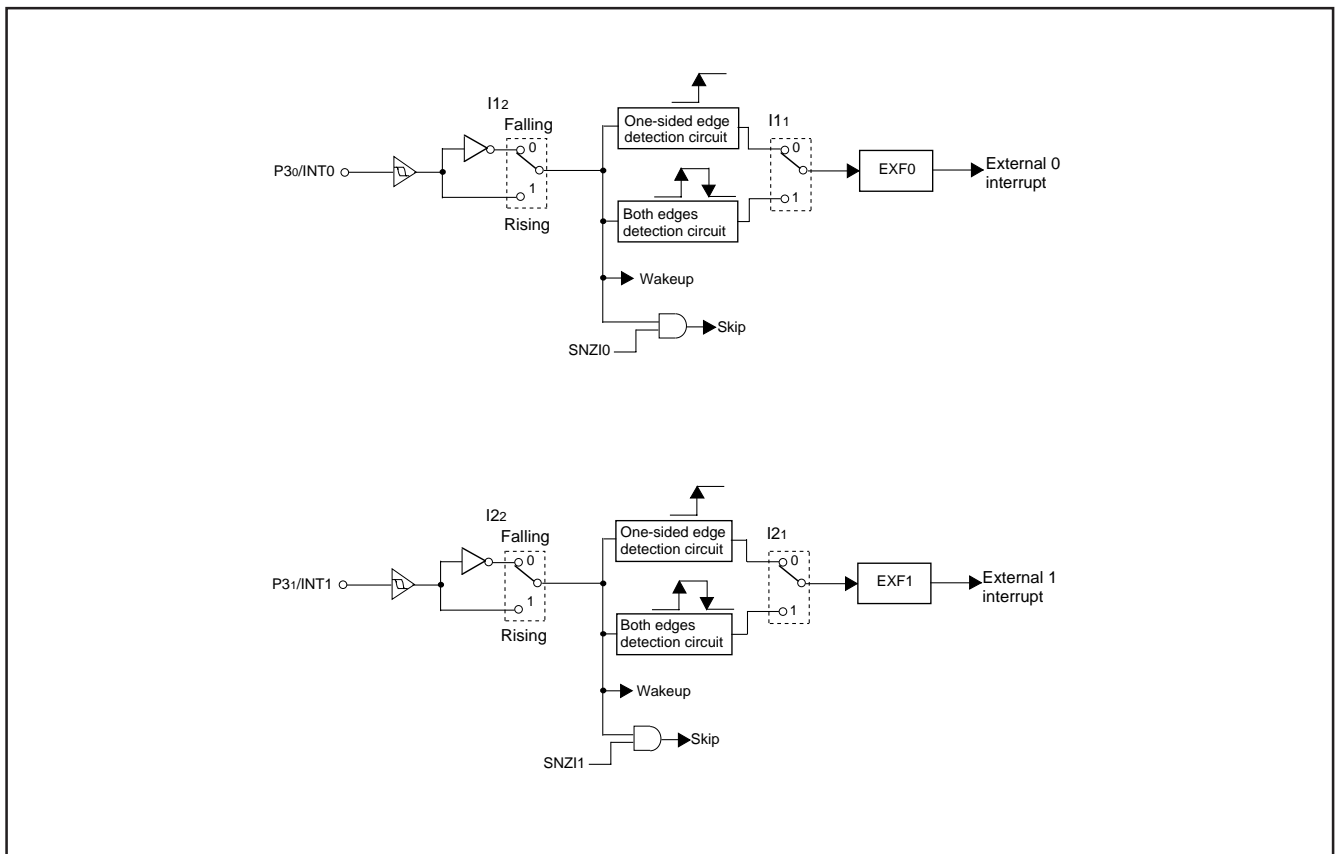

**Fig. 17 External interrupt circuit structure**



**PRELIMINARY**  
 Notice: This is not a final specification.  
 Some parametric limits are subject to  
 change.

### (1) External 0 interrupt request flag (EXF0)

External 0 interrupt request flag (EXF0) is set to "1" when a valid waveform is input to P30/INT0 pin.

The valid waveforms causing the interrupt must be retained at their level for 4 clock cycles or more of the system clock (Refer to Figure 16).

The state of EXF0 flag can be examined with the skip instruction (SNZ0). Use the interrupt control register V1 to select the interrupt or the skip instruction. The EXF0 flag is cleared to "0" when an interrupt occurs or when the next instruction is skipped with the skip instruction.

The P30/INT0 pin need not be selected the external interrupt input INT0 function or the normal I/O port P30 function. However, the EXF0 flag is set to "1" when a valid waveform is input even if it is used as an I/O port P30.

- External 0 interrupt activated condition

External 0 interrupt activated condition is satisfied when a valid waveform is input to P30/INT0 pin.

The valid waveform can be selected from rising waveform, falling waveform or both rising and falling waveforms. An example of how to use the external 0 interrupt is as follows.

- ① Select the valid waveform with the bits 1 and 2 of register I1.
- ② Clear the EXF0 flag to "0" with the SNZ0 instruction.
- ③ Set the NOP instruction for the case when a skip is performed with the SNZ0 instruction.
- ④ Set both the external 0 interrupt enable bit (V10) and the INTE flag to "1."

The external 0 interrupt is now enabled. Now when a valid waveform is input to the P30/INT0 pin, the EXF0 flag is set to "1" and the external 0 interrupt occurs.

### (2) External 1 interrupt request flag (EXF1)

External 1 interrupt request flag (EXF1) is set to "1" when a valid waveform is input to P31/INT1 pin.

The valid waveforms causing the interrupt must be retained at their level for 4 clock cycles or more of the system clock (Refer to Figure 16).

The state of EXF1 flag can be examined with the skip instruction (SNZ1). Use the interrupt control register V1 to select the interrupt or the skip instruction. The EXF1 flag is cleared to "0" when an interrupt occurs or when the next instruction is skipped with the skip instruction.

The P31/INT1 pin need not be selected the external interrupt input INT1 function or the normal I/O port P31 function. However, the EXF1 flag is set to "1" when a valid waveform is input even if it is used as an I/O port P31.

- External 1 interrupt activated condition

External 1 interrupt activated condition is satisfied when a valid waveform is input to P31/INT1 pin.

The valid waveform can be selected from rising waveform, falling waveform or both rising and falling waveforms. An example of how to use the external 1 interrupt is as follows.

- ① Select the valid waveform with the bits 1 and 2 of register I2.
- ② Clear the EXF1 flag to "0" with the SNZ1 instruction.
- ③ Set the NOP instruction for the case when a skip is performed with the SNZ1 instruction.
- ④ Set both the external 1 interrupt enable bit (V11) and the INTE flag to "1."

The external 1 interrupt is now enabled. Now when a valid waveform is input to the P31/INT1 pin, the EXF1 flag is set to "1" and the external 1 interrupt occurs.

**PRELIMINARY**  
 Notice: This is not a final specification.  
 Some parametric limits are subject to  
 change.

**(3) External interrupt control registers**

• Interrupt control register I1

Register I1 controls the valid waveform for the external 0 interrupt. Set the contents of this register through register A with the TI1A instruction. The TAI1 instruction can be used to transfer the contents of register I1 to register A.

• Interrupt control register I2

Register I2 controls the valid waveform for the external 1 interrupt. Set the contents of this register through register A with the TI2A instruction. The TAI2 instruction can be used to transfer the contents of register I2 to register A.

**Table 8 External interrupt control registers**

Interrupt control register I1		at reset : 00002	at RAM back-up : state retained	R/W
I13	Not used	0	This bit has no function, but read/write is enabled.	
		1		
I12	Interrupt valid waveform for INT0 pin/ return level selection bit (Note 2)	0	Falling waveform ("L" level of INT0 pin is recognized with the SNZI0 instruction)/"L" level	
		1	Rising waveform ("H" level of INT0 pin is recognized with the SNZI0 instruction)/"H" level	
I11	INT0 pin edge detection circuit control bit	0	One-sided edge detected	
		1	Both edges detected	
I10	INT0 pin timer 1 control enable bit	0	Disabled	
		1	Enabled	
Interrupt control register I2		at reset : 00002	at RAM back-up : state retained	R/W
I23	Not used	0	This bit has no function, but read/write is enabled.	
		1		
I22	Interrupt valid waveform for INT1 pin/ return level selection bit (Note 3)	0	Falling waveform ("L" level of INT1 pin is recognized with the SNZI1 instruction)/"L" level	
		1	Rising waveform ("H" level of INT1 pin is recognized with the SNZI1 instruction)/"H" level	
I21	INT1 pin edge detection circuit control bit	0	One-sided edge detected	
		1	Both edges detected	
I20	INT1 pin timer 3 control enable bit	0	Disabled	
		1	Enabled	

Notes 1: "R" represents read enabled, and "W" represents write enabled.

2: When the contents of I12 is changed, the external interrupt request flag EXF0 may be set. Accordingly, clear EXF0 flag with the SNZ0 instruction.

3: When the contents of I22 is changed, the external interrupt request flag EXF1 may be set. Accordingly, clear EXF1 flag with the SNZ1 instruction.

**PRELIMINARY**  
 Notice: This is not a final specification.  
 Some parametric limits are subject to change.

**TIMERS**

The 4513/4514 Group has the programmable timers.

- Programmable timer

The programmable timer has a reload register and enables the frequency dividing ratio to be set. It is decremented from a setting value  $n$ . When it underflows (count to  $n + 1$ ), a timer interrupt request flag is set to "1," new data is loaded from the reload register, and count continues (auto-reload function).

- Fixed dividing frequency timer

The fixed dividing frequency timer has the fixed frequency dividing ratio ( $n$ ). An interrupt request flag is set to "1" after every  $n$  count of a count pulse.

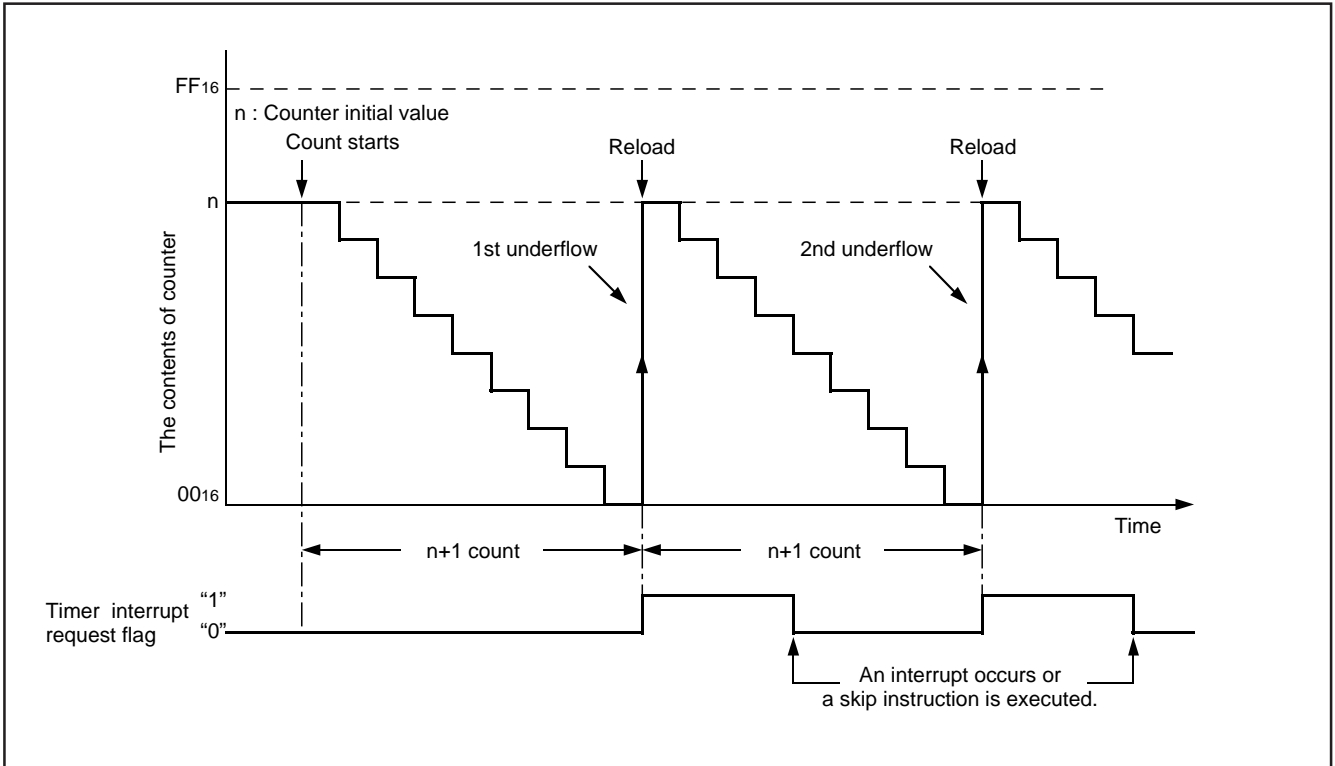

Fig. 18 Auto-reload function

**PRELIMINARY**  
 Notice: This is not a final specification.  
 Some parametric limits are subject to  
 change.

The 4513/4514 Group timer consists of the following circuits.

- Prescaler : frequency divider
- Timer 1 : 8-bit programmable timer
- Timer 2 : 8-bit programmable timer
- Timer 3 : 8-bit programmable timer
- Timer 4 : 8-bit programmable timer
- (Timers 1 to 4 have the interrupt function, respectively)
- 16-bit timer

Prescaler and timers 1 to 4 can be controlled with the timer control registers W1 to W6. The 16-bit timer is a free counter which is not controlled with the control register.

Each function is described below.

**Table 9 Function related timers**

Circuit	Structure	Count source	Frequency dividing ratio	Use of output signal	Control register
Prescaler	Frequency divider	• Instruction clock	4, 16	• Timer 1, 2, 3 and 4 count sources	W1
Timer 1	8-bit programmable binary down counter (link to EXF0)	• Prescaler output (ORCLK)	1 to 256	• Timer 2 count source • CNTR0 output • Timer 1 interrupt	W1 W6
Timer 2	8-bit programmable binary down counter	• Timer 1 underflow • Prescaler output (ORCLK) • CNTR0 input • 16-bit counter underflow	1 to 256	• Timer 3 count source • Timer 2 interrupt • CNTR0 output	W2 W6
Timer 3	8-bit programmable binary down counter (link to EXF1)	• Timer 2 underflow • Prescaler output (ORCLK)	1 to 256	• Timer 4 count source • Timer 3 interrupt • CNTR1 output	W3 W6
Timer 4	8-bit programmable binary down counter	• Timer 3 underflow • Prescaler output (ORCLK) • CNTR1 input	1 to 256	• Timer 4 interrupt • CNTR1 output	W4 W6
16-bit timer	16-bit fixed dividing frequency	• Instruction clock	65536	• Watchdog timer (The 15th bit is counted twice) • Timer 2 count source (16-bit counter underflow)	

**PRELIMINARY**  
 Notice: This is not a final specification.  
 Some parametric limits are subject to  
 change.

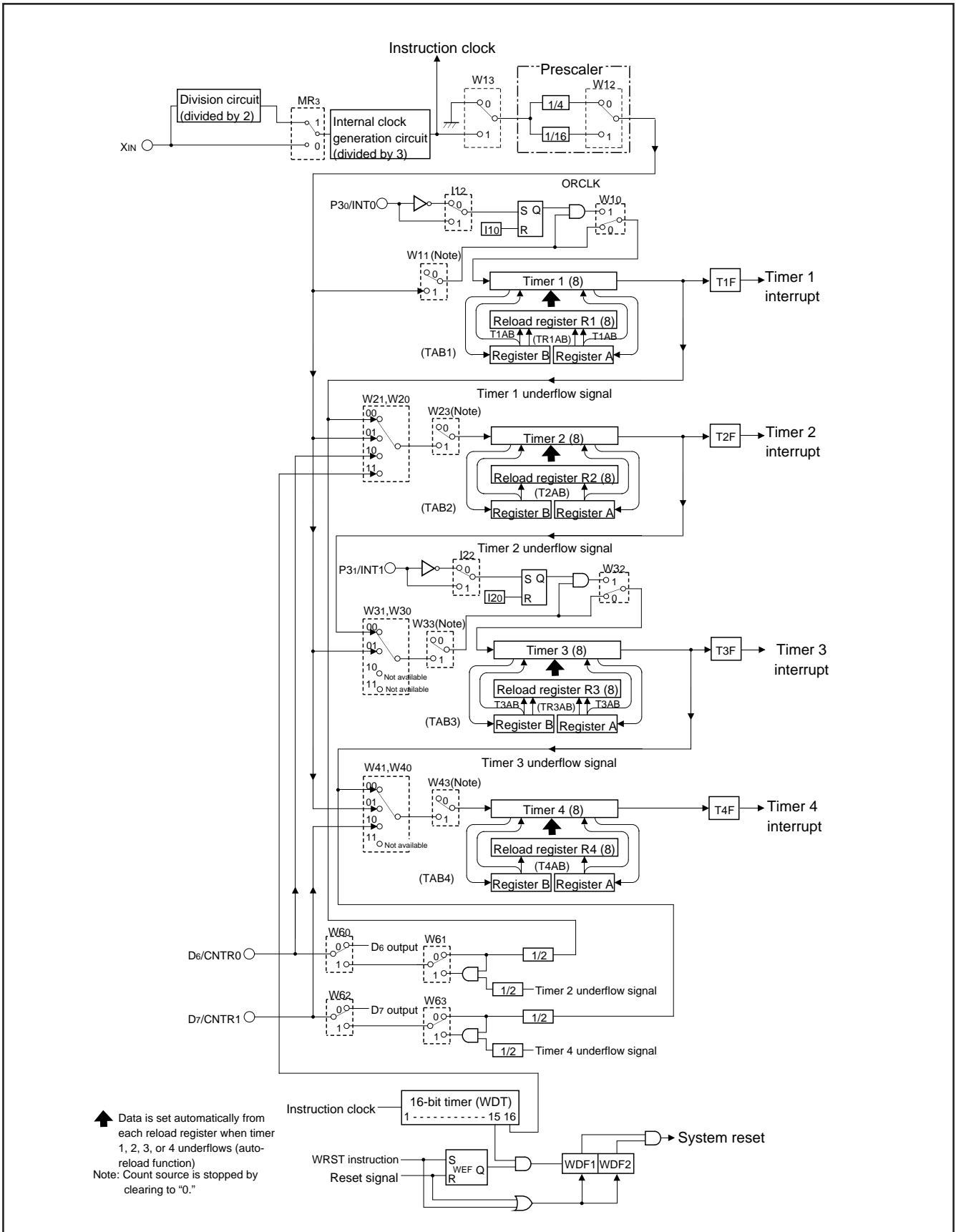

Fig. 19 Timers structure

**PRELIMINARY**  
 Notice: This is not a final specification.  
 Some parametric limits are subject to  
 change.

**Table 10 Timer control registers**

Timer control register W1		at reset : 0000 <sub>2</sub>		at RAM back-up : 0000 <sub>2</sub>		R/W
W13	Prescaler control bit	0	Stop (state initialized)			
		1	Operating			
W12	Prescaler dividing ratio selection bit	0	Instruction clock divided by 4			
		1	Instruction clock divided by 16			
W11	Timer 1 control bit	0	Stop (state retained)			
		1	Operating			
W10	Timer 1 count start synchronous circuit control bit	0	Count start synchronous circuit not selected			
		1	Count start synchronous circuit selected			
Timer control register W2		at reset : 0000 <sub>2</sub>		at RAM back-up : state retained		R/W
W23	Timer 2 control bit	0	Stop (state retained)			
		1	Operating			
W22	Not used	0	This bit has no function, but read/write is enabled.			
		1				
W21	Timer 2 count source selection bits	W21 W20		Count source		
		0	0	Timer 1 underflow signal		
W20		0	1	Prescaler output		
		1	0	CNTR0 input		
		1	1	16 bit timer (WDT) underflow signal		
Timer control register W3		at reset : 0000 <sub>2</sub>		at RAM back-up : state retained		R/W
W33	Timer 3 control bit	0	Stop (state retained)			
		1	Operating			
W32	Timer 3 count start synchronous circuit control bit	0	Count start synchronous circuit not selected			
		1	Count start synchronous circuit selected			
W31	Timer 3 count source selection bits	W31 W30		Count source		
		0	0	Timer 2 underflow signal		
W30		0	1	Prescaler output		
		1	0	Not available		
		1	1	Not available		
Timer control register W4		at reset : 0000 <sub>2</sub>		at RAM back-up : state retained		R/W
W43	Timer 4 control bit	0	Stop (state retained)			
		1	Operating			
W42	Not used	0	This bit has no function, but read/write is enabled.			
		1				
W41	Timer 4 count source selection bits	W41 W40		Count source		
		0	0	Timer 3 underflow signal		
W40		0	1	Prescaler output		
		1	0	CNTR1 input		
		1	1	Not available		
Timer control register W6		at reset : 0000 <sub>2</sub>		at RAM back-up : state retained		R/W
W63	CNTR1 output control bit	0	Timer 3 underflow signal output divided by 2			
		1	CNTR1 output control by timer 4 underflow signal divided by 2			
W62	D7/CNTR1 function selection bit	0	D7(I/O)/CNTR1 input			
		1	CNTR1 (I/O)/D7(input)			
W61	CNTR0 output control bit	0	Timer 1 underflow signal output divided by 2			
		1	CNTR0 output control by timer 2 underflow signal divided by 2			
W60	D6/CNTR0 output control bit	0	D6(I/O)/CNTR0 input			
		1	CNTR0 (I/O)/D6(input)			

Note: "R" represents read enabled, and "W" represents write enabled.

**PRELIMINARY**  
 Notice: This is not a final specification.  
 Some parametric limits are subject to  
 change.

## (1) Timer control registers

- **Timer control register W1**  
 Register W1 controls the count operation of timer 1, the selection of count start synchronous circuit, and the frequency dividing ratio and count operation of prescaler. Set the contents of this register through register A with the TW1A instruction. The TAW1 instruction can be used to transfer the contents of register W1 to register A.
- **Timer control register W2**  
 Register W2 controls the count operation and count source of timer 2. Set the contents of this register through register A with the TW2A instruction. The TAW2 instruction can be used to transfer the contents of register W2 to register A.
- **Timer control register W3**  
 Register W3 controls the count operation and count source of timer 3 and the selection of count start synchronous circuit. Set the contents of this register through register A with the TW3A instruction. The TAW3 instruction can be used to transfer the contents of register W3 to register A.
- **Timer control register W4**  
 Register W4 controls the count operation and count source of timer 4. Set the contents of this register through register A with the TW4A instruction. The TAW4 instruction can be used to transfer the contents of register W4 to register A.
- **Timer control register W6**  
 Register W6 controls the D6/CNTR0 pin and D7/CNTR1 functions, the selection and operation of the CNTR0 and CNTR1 output. Set the contents of this register through register A with the TW6A instruction. The TAW6 instruction can be used to transfer the contents of register W6 to register A.

## (2) Precautions

Note the following for the use of timers.

- **Prescaler**  
 Stop the prescaler operation to change its frequency dividing ratio.
- **Count source**  
 Stop timer 1, 2, 3, or 4 counting to change its count source.
- **Reading the count value**  
 Stop timer 1, 2, 3, or 4 counting and then execute the TAB1, TAB2, TAB3, or TAB4 instruction to read its data.
- **Writing to reload registers R1 and R3**  
 When writing data to reload registers R1 or R3 while timer 1 or timer 3 is operating, avoid a timing when timer 1 or timer 3 underflows.

## (3) Prescaler

Prescaler is a frequency divider. Its frequency dividing ratio can be selected. The count source of prescaler is the instruction clock.

Use the bit 2 of register W1 to select the prescaler dividing ratio and the bit 3 to start and stop its operation. Prescaler is initialized, and the output signal (ORCLK) stops when the bit 3 of register W1 is cleared to "0."

## (4) Timer 1 (interrupt function)

Timer 1 is an 8-bit binary down counter with the timer 1 reload register (R1). Data can be set simultaneously in timer 1 and the reload register (R1) with the T1AB instruction. Data can be written to reload register (R1) with the TR1AB instruction.

When writing data to reload register R1 with the TR1AB instruction, the downcount after the underflow is started from the setting value of reload register R1.

Timer 1 starts counting after the following process;

- ① set data in timer 1, and
- ② set the bit 1 of register W1 to "1."

However, P30/INT0 pin input can be used as the start trigger for timer 1 count operation by setting the bit 0 of register W1 to "1."

Once count is started, when timer 1 underflows (the next count pulse is input after the contents of timer 1 becomes "0"), the timer 1 interrupt request flag (T1F) is set to "1," new data is loaded from reload register R1, and count continues (auto-reload function).

When a value set in reload register R1 is  $n$ , timer 1 divides the count source signal by  $n + 1$  ( $n = 0$  to 255).

Data can be read from timer 1 with the TAB1 instruction. When reading the data, stop the counter and then execute the TAB1 instruction. Timer 1 underflow signal divided by 2 can be output from D6/CNTR0 pin.

## (5) Timer 2 (interrupt function)

Timer 2 is an 8-bit binary down counter with the timer 2 reload register (R2). Data can be set simultaneously in timer 2 and the reload register (R2) with the T2AB instruction.

Timer 2 starts counting after the following process;

- ① set data in timer 2,
- ② select the count source with the bits 0 and 1 of register W2, and
- ③ set the bit 3 of register W2 to "1."

Once count is started, when timer 2 underflows (the next count pulse is input after the contents of timer 2 becomes "0"), the timer 2 interrupt request flag (T2F) is set to "1," new data is loaded from reload register R2, and count continues (auto-reload function).

When a value set in reload register R2 is  $n$ , timer 2 divides the count source signal by  $n + 1$  ( $n = 0$  to 255).

Data can be read from timer 2 with the TAB2 instruction. When reading the data, stop the counter and then execute the TAB2 instruction. The output from D6/CNTR0 pin by timer 2 underflow signal divided by 2 can be controlled.

**PRELIMINARY**  
 Notice: This is not a final specification.  
 Some parametric limits are subject to  
 change.

### (6) Timer 3 (interrupt function)

Timer 3 is an 8-bit binary down counter with the timer 3 reload register (R3). Data can be set simultaneously in timer 3 and the reload register (R3) with the T3AB instruction. Data can be written to reload register (R3) with the TR3AB instruction.

When writing data to reload register R3 with the TR3AB instruction, the downcount after the underflow is started from the setting value of reload register R3.

Timer 3 starts counting after the following process;

- ① set data in timer 3,
- ② select the count source with the bits 0 and 1 of register W3, and
- ③ set the bit 3 of register W3 to "1."

However, P31/INT1 pin input can be used as the start trigger for timer 3 count operation by setting the bit 2 of register W3 to "1."

Once count is started, when timer 3 underflows (the next count pulse is input after the contents of timer 3 becomes "0"), the timer 3 interrupt request flag (T3F) is set to "1," new data is loaded from reload register R3, and count continues (auto-reload function).

When a value set in reload register R3 is  $n$ , timer 3 divides the count source signal by  $n + 1$  ( $n = 0$  to 255).

Data can be read from timer 3 with the TAB3 instruction. When reading the data, stop the counter and then execute the TAB3 instruction. Timer 3 underflow signal divided by 2 can be output from D7/CNTR1 pin.

### (7) Timer 4 (interrupt function)

Timer 4 is an 8-bit binary down counter with the timer 4 reload register (R4). Data can be set simultaneously in timer 4 and the reload register (R4) with the T4AB instruction.

Timer 4 starts counting after the following process;

- ① set data in timer 4,
- ② select the count source with the bits 0 and 1 of register W4, and
- ③ set the bit 3 of register W4 to "1."

Once count is started, when timer 4 underflows (the next count pulse is input after the contents of timer 4 becomes "0"), the timer 4 interrupt request flag (T4F) is set to "1," new data is loaded from reload register R4, and count continues (auto-reload function).

When a value set in reload register R4 is  $n$ , timer 4 divides the count source signal by  $n + 1$  ( $n = 0$  to 255).

Data can be read from timer 4 with the TAB4 instruction. When reading the data, stop the counter and then execute the TAB4 instruction. The output from D7/CNTR1 pin by timer 4 underflow signal divided by 2 can be controlled.

### (8) Timer I/O pin (D6/CNTR0, D7/CNTR1)

D6/CNTR0 pin has functions to input the timer 2 count source, and to output the timer 1 and timer 2 underflow signals divided by 2.

D7/CNTR1 pin has functions to input the timer 4 count source, and to output the timer 3 and timer 4 underflow signals divided by 2.

The selection of D6/CNTR0 pin function can be controlled with the bit 0 of register W6. The selection of D7/CNTR1 pin function can be controlled with the bit 2 of register W6.

The following signals can be selected for the CNTR0 output signal with the bit 1 of register W6.

- timer 1 underflow signal divided by 2
- the signal of AND operation between timer 1 underflow signal divided by 2 and timer 2 underflow signal divide by 2

The following signals can be selected for the CNTR1 output signal with the bit 3 of register W6.

- timer 3 underflow signal divided by 2
- the signal of AND operation between timer 3 underflow signal divided by 2 and timer 4 underflow signal divide by 2

Timer 2 counts the rising waveform of CNTR0 input when the CNTR0 input is selected as the count source.

Timer 4 counts the rising waveform of CNTR1 input when the CNTR1 input is selected as the count source.

### (9) Timer interrupt request flags (T1F, T2F, T3F, and T4F)

Each timer interrupt request flag is set to "1" when each timer underflows. The state of these flags can be examined with the skip instructions (SNZT1, SNZT2, SNZT3, and SNZT4).

Use the interrupt control registers V1, V2 to select an interrupt or a skip instruction.

An interrupt request flag is cleared to "0" when an interrupt occurs or when the next instruction is skipped with a skip instruction.

### (10) Count start synchronization circuit (timer 1, timer 3)

Each timer 1 and timer 3 has the count start synchronization circuit which synchronize P30/INT0 pin and P31/INT1 pin, respectively, and can start the timer count operation.

Timer 1 count start synchronization circuit function is selected by setting the bit 0 of register W1 to "1." The control by P30/INT0 pin input can be performed by setting the bit 0 of register I1 to "1."

P30/INT0 pin input level can be selected by the bit 2 of register I1 as follows;

- I12 = "0": The count start synchronizes the "L" level of P30/INT0 pin
- I12 = "1": The count start synchronizes the "H" level of P30/INT0 pin

Timer 3 count start synchronization circuit function is selected by setting the bit 2 of register W3 to "1." The control by P31/INT1 pin input can be performed by setting the bit 0 of register I2 to "1."

P31/INT1 pin input level can be selected by the bit 2 of register I2 as follows;

- I22 = "0": The count start synchronizes the "L" level of P31/INT1 pin
- I22 = "1": The count start synchronizes the "H" level of P31/INT1 pin

When timer 1 and timer 3 count start synchronization circuits are used, the count start synchronization circuits are set, the count source is input to each timer by inputting valid levels to P30/INT0 pin and P31/INT1 pin. Once set, the count start synchronization circuit is cleared by clearing the bit I10 or I20 to "0" or reset.



**PRELIMINARY**  
 Notice: This is not a final specification.  
 Some parametric limits are subject to change.

**WATCHDOG TIMER**

Watchdog timer provides a method to reset the system when a program runs wild. Watchdog timer consists of a 16-bit timer (WDT), watchdog timer enable flag (WEF), and watchdog timer flags (WDF1, WDF2).

The timer WDT downcounts the instruction clocks as the count source. The underflow signal is generated when the count value reaches "0000<sub>16</sub>." This underflow signal can be used as the timer 2 count source.

When the WRST instruction is executed after system is released from reset, the WEF flag is set to "1". At this time, the watchdog timer starts operating.

When the count value of timer WDT reaches "BFFF<sub>16</sub>" or "3FFF<sub>16</sub>," the WDF1 flag is set to "1." If the WRST instruction is never executed while timer WDT counts 32767, WDF2 flag is set to "1," and the RESET pin outputs "L" level to reset the microcomputer. Execute the WRST instruction at each period of 32766 machine cycle or less by software when using watchdog timer to keep the microcomputer operating normally.

To prevent the WDT stopping in the event of misoperation, WEF flag is designed not to initialize once the WRST instruction has been executed. Note also that, if the WRST instruction is never executed, the watchdog timer does not start.

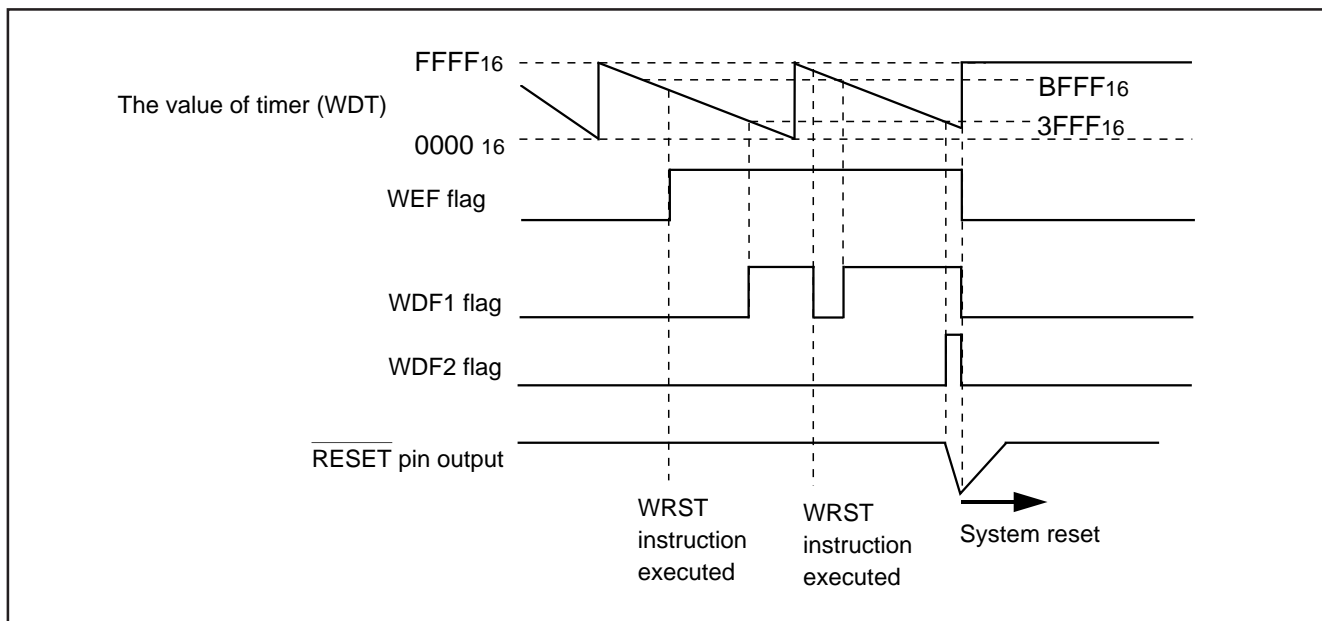
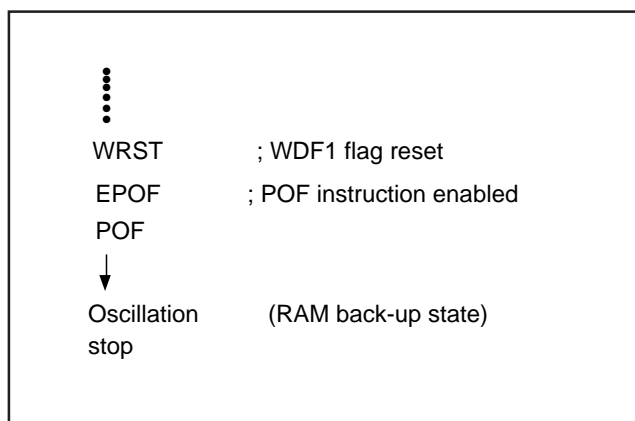

**Fig. 20 Watchdog timer function**

The contents of WEF, WDF1 and WDF2 flags and timer WDT are initialized at the RAM back-up mode.

If WDF2 flag is set to "1" at the same time that the microcomputer enters the RAM back-up state, system reset may be performed.

When using the watchdog timer and the RAM back-up mode, initialize the WDF1 flag with the WRST instruction just before the microcomputer enters the RAM back-up state (refer to Figure 21)



**Fig. 21 Program example to enter the RAM back-up mode when using the watchdog timer**

**PRELIMINARY**  
 Notice: This is not a final specification.  
 Some parametric limits are subject to change.

**SERIAL I/O**

The 4513/4514 Group has a built-in clock synchronous serial I/O which can serially transmit or receive 8-bit data.

Serial I/O consists of;

- serial I/O register SI
- serial I/O mode register J1
- serial I/O transmission/reception completion flag (SIOF)
- serial I/O counter

Registers A and B are used to perform data transfer with internal CPU, and the serial I/O pins are used for external data transfer.

The pin functions of the serial I/O pins can be set with the register J1.

**Table 11 Serial I/O pins**

Pin	Pin function when selecting serial I/O
P20/SCK	Clock I/O (SCK)
P21/SOUT	Serial data output (SOUT)
P22/SIN	Serial data input (SIN)

Note: Input ports P20–P22 can be used regardless of register J1.

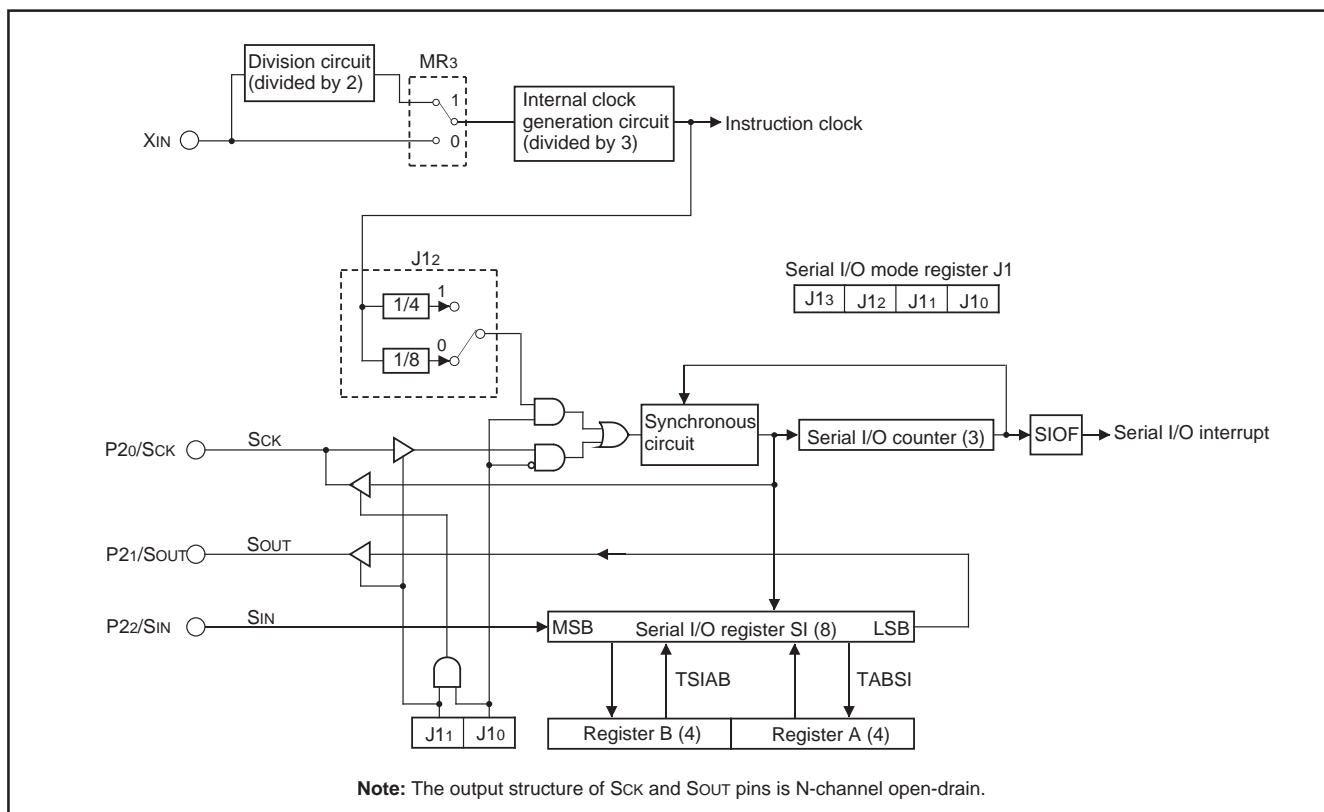

**Fig. 22 Serial I/O structure**

**Table 12 Serial I/O mode register**

Serial I/O mode register J1		at reset : 00002	at RAM back-up : state retained	R/W
J13	Not used	0 1	This bit has no function, but read/write is enabled.	
J12	Serial I/O internal clock dividing ratio selection bit	0 1		
J11	Serial I/O port selection bit	0 1	Input ports P20, P21, P22 selected Serial I/O ports SCK, SOUT, SIN/input ports P20, P21, P22 selected	
J10	Serial I/O synchronous clock selection bit	0 1	External clock Internal clock (instruction clock divided by 4 or 8)	

Note: "R" represents read enabled, and "W" represents write enabled.

**PRELIMINARY**  
 Notice: This is not a final specification.  
 Some parametric limits are subject to  
 change.

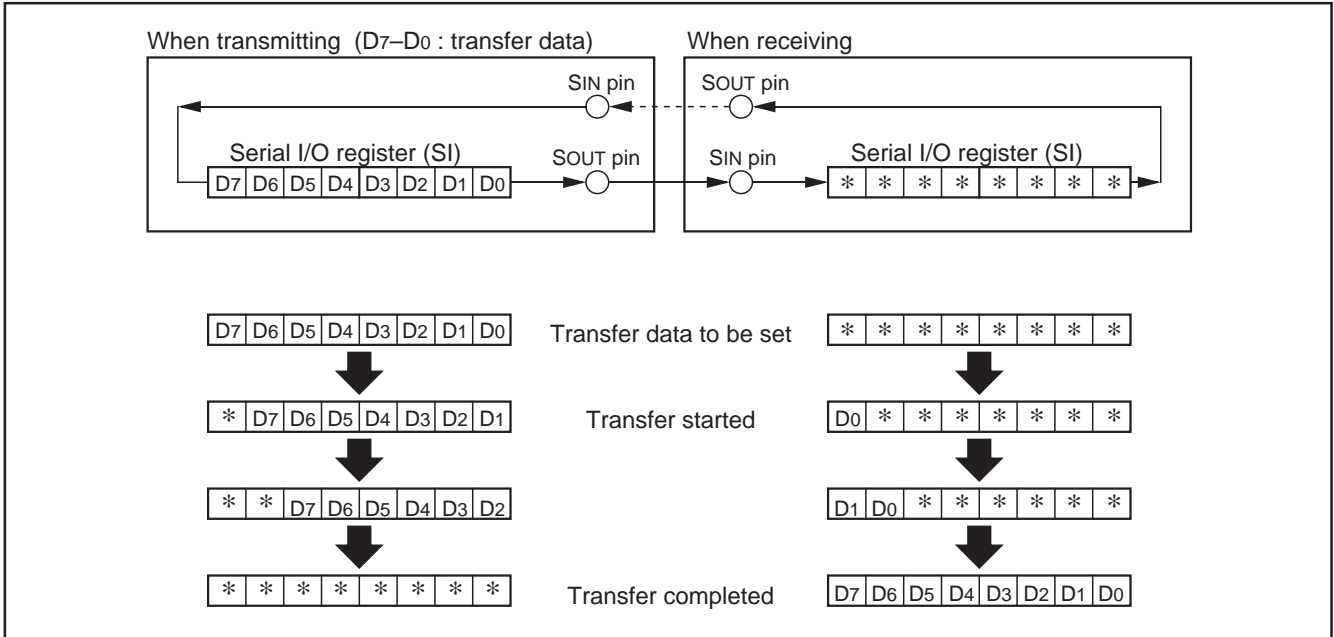

Fig. 23 Serial I/O register state when transferring

**(1) Serial I/O register SI**

Serial I/O register SI is the 8-bit data transfer serial/parallel conversion register. Data can be set to register SI through registers A and B with the TSIAB instruction. The contents of register A is transmitted to the low-order 4 bits of register SI, and the contents of register B is transmitted to the high-order 4 bits of register SI. During transmission, each bit data is transmitted LSB first from the lowermost bit (bit 0) of register SI, and during reception, each bit data is received LSB first to register SI starting from the topmost bit (bit 7).

When register SI is used as a work register without using serial I/O, pull up the Sck pin or set the pin function to an input port P20.

**(2) Serial I/O transmission/reception completion flag (SIOF)**

Serial I/O transmission/reception completion flag (SIOF) is set to "1" when serial data transmission or reception completes. The state of SIOF flag can be examined with the skip instruction (SNZSI). Use the interrupt control register V2 to select the interrupt or the skip instruction.

The SIOF flag is cleared to "0" when the interrupt occurs or when the next instruction is skipped with the skip instruction.

**(3) Serial I/O start instruction (SST)**

When the SST instruction is executed, the SIOF flag is cleared to "0" and then serial I/O transmission/reception is started.

**(4) Serial I/O mode register J1**

Register J1 controls the synchronous clock, P20/Sck, P21/Sout and P22/Sin pin function. Set the contents of this register through register A with the TJ1A instruction. The TAJ1 instruction can be used to transfer the contents of register J1 to register A.

**(5) How to use serial I/O**

Figure 24 shows the serial I/O connection example. Serial I/O interrupt is not used in this example. In the actual wiring, pull up the

wiring between each pin with a resistor. Figure 25 shows the data transfer timing and Table 13 shows the data transfer sequence.

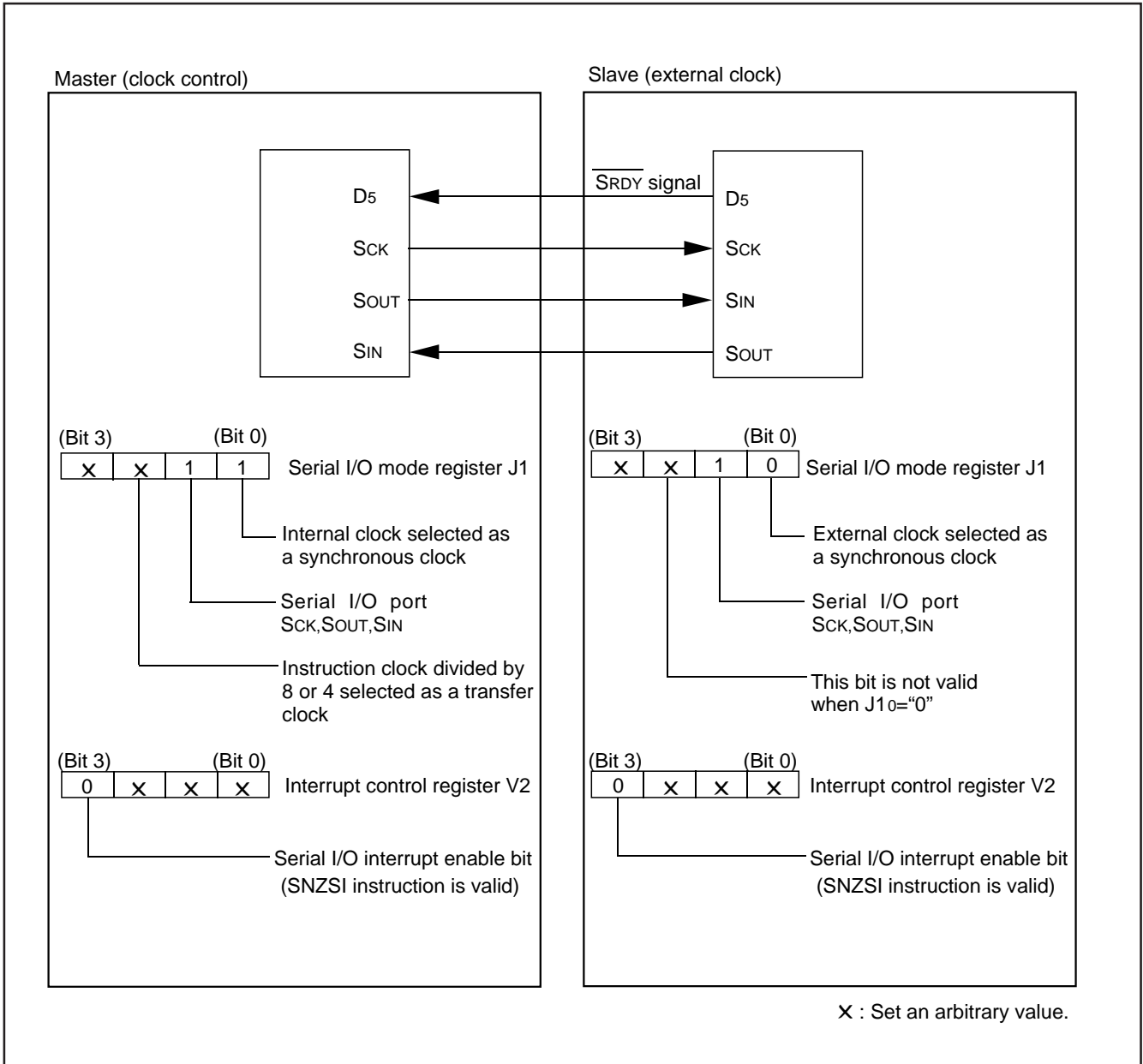

Fig. 24 Serial I/O connection example

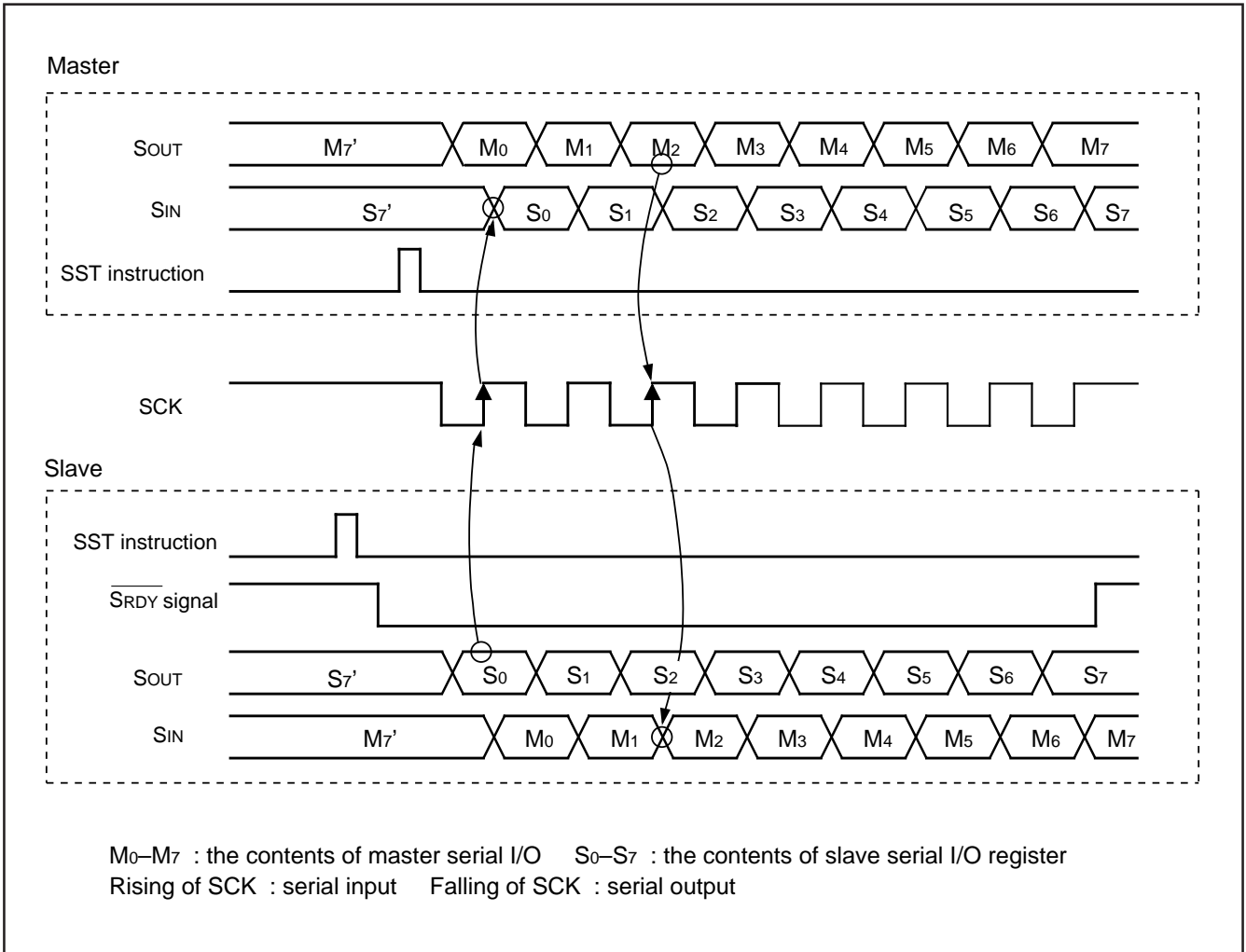

Fig. 25 Timing of serial I/O data transfer

**PRELIMINARY**  
 Notice: This is not a final specification.  
 Some parametric limits are subject to  
 change.

**Table 13 Processing sequence of data transfer from master to slave**

Master (transmission)	Slave (reception)
[Initial setting] • Setting the serial I/O mode register J1 and interrupt control register V2 shown in Figure 24.	[Initial setting] • Setting serial I/O mode register J1, and interrupt control register V2 shown in Figure 24.
TJ1A and TV2A instructions	TJ1A and TV2A instructions
• Setting the port received the reception enable signal (SRDY) to the input mode. (Port D5 is used in this example)	• Setting the port received the reception enable signal (SRDY) and outputting "H" level (reception impossible). (Port D5 is used in this example)
SD instruction	SD instruction
* [Transmission enable state] • Storing transmission data to serial I/O register SI.	*[Reception enable state] • The SIOF flag is cleared to "0."
TSIAB instruction	SST instruction
	• "L" level (reception possible) is output from port D5.
	RD instruction
[Transmission] • Check port D5 is "L" level.	[Reception]
SZD instruction	
• Serial transfer starts.	
SST instruction	
• Check transmission completes.	• Check reception completes.
SNZSI instruction	SNZSI instruction
• Wait (timing when continuously transferring)	• "H" level is output from port D5.
	SD instruction
	[Data processing]

1-byte data is serially transferred on this process. Subsequently, data can be transferred continuously by repeating the process from \*.  
 When an external clock is selected as a synchronous clock, the clock is not controlled internally. Control the clock externally because serial transfer is performed as long as clock is externally input. (Unlike an internal clock, an external clock is not stopped when serial transfer is completed.) However, the SIOF flag is set to "1" when the clock is counted 8 times after executing the SST instruction. Be sure to set the initial level of the external clock to "H."

**PRELIMINARY**  
 Notice: This is not a final specification.  
 Some parametric limits are subject to  
 change.

**A-D CONVERTER**

The 4513/4514 Group has a built-in A-D conversion circuit that performs conversion by 10-bit successive comparison method. Table 14 shows the characteristics of this A-D converter. This A-D converter can also be used as an 8-bit comparator to compare analog voltages input from the analog input pin with preset values.

**Table 14 A-D converter characteristics**

Parameter	Characteristics
Conversion format	Successive comparison method
Resolution	10 bits
Absolute accuracy	Linearity error: $\pm 2\text{LSB}$
	Non-linearity error: $\pm 0.9\text{LSB}$
Conversion speed	46.5 $\mu\text{s}$ (High-speed mode at 4.0 MHz oscillation frequency)
Analog input pin	4 for 4513 Group
	8 for 4514 Group

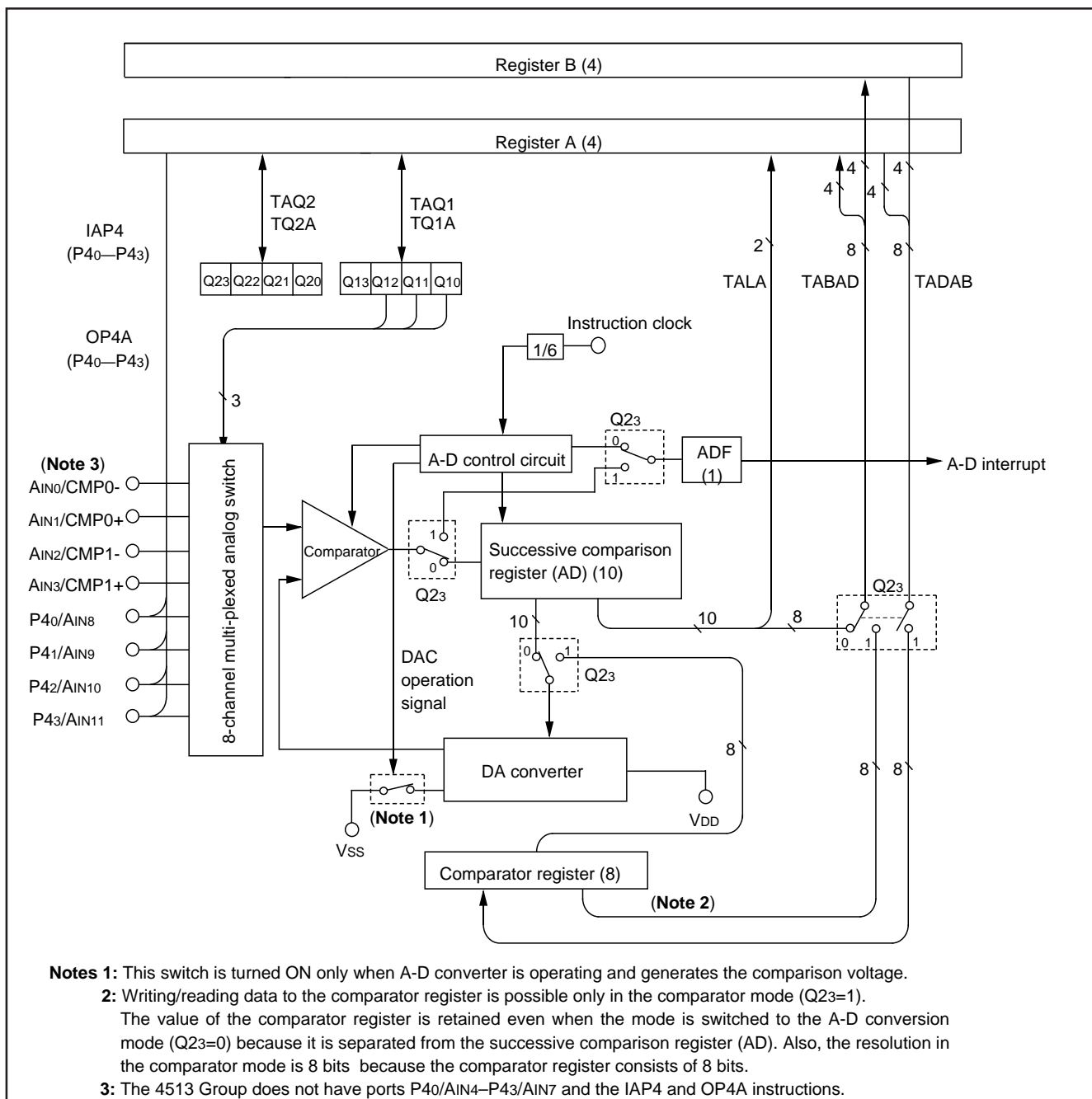

**Fig. 26 A-D conversion circuit structure**

**PRELIMINARY**  
 Notice: This is not a final specification.  
 Some parametric limits are subject to  
 change.

Table 15 A-D control registers

A-D control register Q1		at reset : 00002			at RAM back-up : state retained	R/W
Q13	Not used	0			This bit has no function, but read/write is enabled.	
		1				
Q12	Analog input pin selection bits (Note 2)	Q12	Q11	Q10	Selected pins	
		0	0	0	AIN0	
0		0	1	AIN1		
Q11		0	1	0	AIN2	
		0	1	1	AIN3	
Q10		1	0	0	AIN4 (Not available for the 4513 Group)	
		1	0	1	AIN5 (Not available for the 4513 Group)	
		1	1	0	AIN6 (Not available for the 4513 Group)	
	1	1	1	AIN7 (Not available for the 4513 Group)		
A-D control register Q2		at reset : 00002			at RAM back-up : state retained	R/W
Q23	A-D operation mode selection bit	0			A-D conversion mode	
		1			Comparator mode	
Q22	P43/AIN7 and P42/AIN6 pin function selection bit (Not used for the 4513 Group)	0			P43, P42 (read/write enabled for the 4513 Group)	
		1			AIN7, AIN6/P43, P42 (read/write enabled for the 4513 Group)	
Q21	P41/AIN5 pin function selection bit (Not used for the 4513 Group)	0			P41 (read/write enabled for the 4513 Group)	
		1			AIN5/P41 (read/write enabled for the 4513 Group)	
Q20	P40/AIN4 pin function selection bit (Not used for the 4513 Group)	0			P40 (read/write enabled for the 4513 Group)	
		1			AIN4/P40 (read/write enabled for the 4513 Group)	

Notes 1: "R" represents read enabled, and "W" represents write enabled.

2: Select AIN4–AIN7 with register Q1 after setting register Q2.

### (1) Operating at A-D conversion mode

The A-D conversion mode is set by setting the bit 3 of register Q2 to "0."

### (2) Successive comparison register AD

Register AD stores the A-D conversion result of an analog input in 10-bit digital data format. The contents of the high-order 8 bits of this register can be stored in register B and register A with the TABAD instruction. The contents of the low-order 2 bits of this register can be stored into the high-order 2 bits of register A with the TALA instruction. However, do not execute this instruction during A-D conversion.

When the contents of register AD is  $n$ , the logic value of the comparison voltage  $V_{ref}$  generated from the built-in DA converter can be obtained with the reference voltage  $V_{DD}$  by the following formula:

Logic value of comparison voltage  $V_{ref}$

$$V_{ref} = \frac{V_{DD}}{1024} \times n$$

$n$ : The value of register AD ( $n = 0$  to 1023)

### (3) A-D conversion completion flag (ADF)

A-D conversion completion flag (ADF) is set to "1" when A-D conversion completes. The state of ADF flag can be examined with the skip instruction (SNZAD). Use the interrupt control register V2 to select the interrupt or the skip instruction.

The ADF flag is cleared to "0" when the interrupt occurs or when the next instruction is skipped with the skip instruction.

### (4) A-D conversion start instruction (ADST)

A-D conversion starts when the ADST instruction is executed. The conversion result is automatically stored in the register AD.

### (5) A-D control register Q1

Register Q1 is used to select one of analog input pins. The 4513 Group does not have AIN4–AIN7. Accordingly, do not select these pins with register Q1.

### (6) A-D control register Q2

Register Q2 is used to select the pin function of P40/AIN4, P41/AIN5, P42/AIN6, and P43/AIN7. The A-D conversion mode is selected when the bit 3 of register Q2 is "0," and the comparator mode is selected when the bit 3 of register Q2 is "1." After set this register, select the analog input with register Q1.

Even when register Q2 is used to set the pins for analog input, P40/AIN4–P43/AIN7 continue to function as P40–P43 I/O. Accordingly, when any of them are used as I/O port P4 and others are used as analog input pins, make sure to set the outputs of pins that are set for analog input to "1." Also, for the port input, the port input function of the pin functions as analog input is undefined.



**PRELIMINARY**  
 Notice: This is not a final specification.  
 Some parametric limits are subject to change.

**(7) Operation description**

A-D conversion is started with the A-D conversion start instruction (ADST). The internal operation during A-D conversion is as follows:

- ① When A-D conversion starts, the register AD is cleared to "00016."
- ② Next, the topmost bit of the register AD is set to "1," and the comparison voltage  $V_{ref}$  is compared with the analog input voltage  $V_{IN}$ .
- ③ When the comparison result is  $V_{ref} < V_{IN}$ , the topmost bit of the register AD remains set to "1." When the comparison result is  $V_{ref} > V_{IN}$ , it is cleared to "0."

The 4513/4514 Group repeats this operation to the lowermost bit of the register AD to convert an analog value to a digital value. A-D conversion stops after 62 machine cycles (46.5  $\mu$ s when  $f(X_{IN}) = 4.0$  MHz in high-speed mode) from the start, and the conversion result is stored in the register AD. An A-D interrupt activated condition is satisfied and the ADF flag is set to "1" as soon as A-D conversion completes (Figure 27).

**Table 16 Change of successive comparison register AD during A-D conversion**

At starting conversion	Change of successive comparison register AD							Comparison voltage ( $V_{ref}$ ) value		
1st comparison	1	0	0	----	0	0	0	$\frac{V_{DD}}{2}$		
2nd comparison	*1	1	0	----	0	0	0	$\frac{V_{DD}}{2} \pm \frac{V_{DD}}{4}$		
3rd comparison	*1	*2	1	----	0	0	0	$\frac{V_{DD}}{2} \pm \frac{V_{DD}}{4} \pm \frac{V_{DD}}{8}$		
After 10th comparison completes	A-D conversion result							$\frac{V_{DD}}{2} \pm \dots \pm \frac{V_{DD}}{1024}$		
	*1	*2	*3	----	*8	*9	*A			

- \*1: 1st comparison result
- \*3: 3rd comparison result
- \*9: 9th comparison result

- \*2: 2nd comparison result
- \*8: 8th comparison result
- \*A: Ath comparison result

**PRELIMINARY**  
 Notice: This is not a final specification.  
 Some parametric limits are subject to change.

**(8) A-D conversion timing chart**

Figure 27 shows the A-D conversion timing chart.

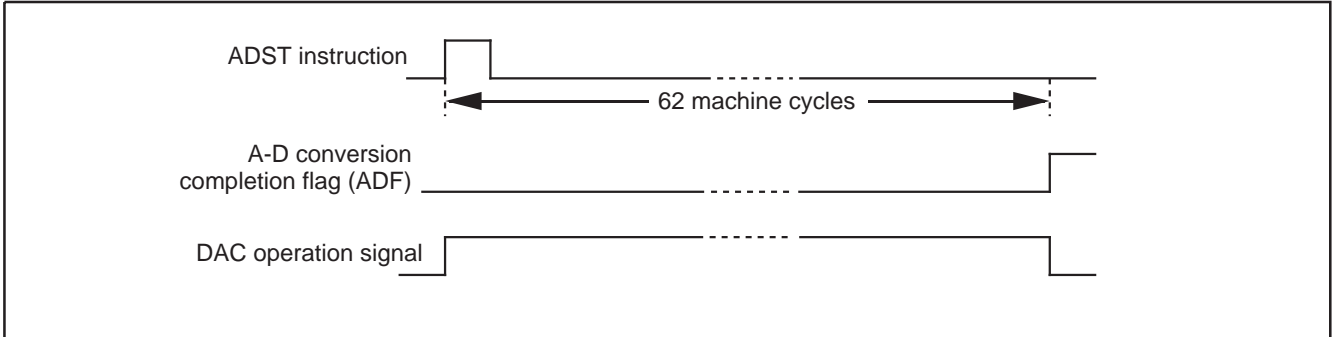

Fig. 27 A-D conversion timing chart

**(9) How to use A-D conversion**

How to use A-D conversion is explained using as example in which the analog input from P40/AIN4 pin is A-D converted, and the high-order 4 bits of the converted data are stored in address M(Z, X, Y) = (0, 0, 0), the middle-order 4 bits in address M(Z, X, Y) = (0, 0, 1), and the low-order 2 bits in address M(Z, X, Y) = (0, 0, 2) of RAM. The A-D interrupt is not used in this example.

- ① After selecting the AIN4 pin function with the bit 0 of the register Q2, select AIN4 pin and A-D conversion mode with the register Q1 (refer to Figure 28).
- ② Execute the ADST instruction and start A-D conversion.
- ③ Examine the state of ADF flag with the SNZAD instruction to determine the end of A-D conversion.
- ④ Transfer the low-order 2 bits of converted data to the high-order 2 bits of register A (TALA instruction).
- ⑤ Transfer the contents of register A to M(Z, X, Y) = (0, 0, 2).
- ⑥ Transfer the high-order 8 bits of converted data to registers A and B (TABAD instruction).
- ⑦ Transfer the contents of register A to M(Z, X, Y) = (0, 0, 1).
- ⑧ Transfer the contents of register B to register A, and then, store into M(Z, X, Y) = (0, 0, 0).

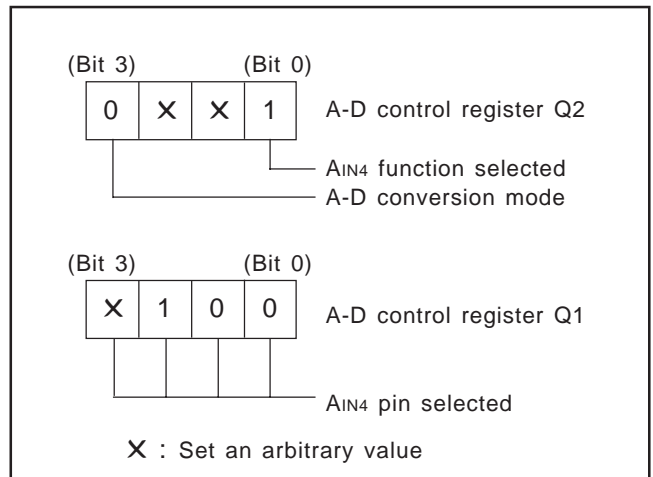

Fig. 28 Setting registers

**PRELIMINARY**  
 Notice: This is not a final specification.  
 Some parametric limits are subject to change.

**(10) Operation at comparator mode**

The A-D converter is set to comparator mode by setting bit 3 of the register Q2 to "1."

Below, the operation at comparator mode is described.

**(11) Comparator register**

In comparator mode, the built-in DA comparator is connected to the comparator register as a register for setting comparison voltages. The contents of register B is stored in the high-order 4 bits of the comparator register and the contents of register A is stored in the low-order 4 bits of the comparator register with the TADAB instruction.

When changing from A-D conversion mode to comparator mode, the result of A-D conversion (register AD) is undefined.

However, because the comparator register is separated from register AD, the value is retained even when changing from comparator mode to A-D conversion mode. Note that the comparator register can be written and read at only comparator mode.

If the value in the comparator register is n, the logic value of comparison voltage  $V_{ref}$  generated by the built-in DA converter can be determined from the following formula:

Logic value of comparison voltage  $V_{ref}$

$$V_{ref} = \frac{V_{DD}}{256} \times n$$

n: The value of register AD (n = 0 to 255)

**(12) Comparison result store flag (ADF)**

In comparator mode, the ADF flag, which shows completion of A-D conversion, stores the results of comparing the analog input voltage with the comparison voltage. When the analog input voltage is lower than the comparison voltage, the ADF flag is set to "1." The state of ADF flag can be examined with the skip instruction (SNZAD). Use the interrupt control register V2 to select the interrupt or the skip instruction.

The ADF flag is cleared to "0" when the interrupt occurs or when the next instruction is skipped with the skip instruction.

**(13) Comparator operation start instruction (ADST instruction)**

In comparator mode, executing ADST starts the comparator operating.

The comparator stops 8 machine cycles after it has started (6  $\mu$ s at  $f(X_{IN}) = 4.0$  MHz in high-speed mode). When the analog input voltage is lower than the comparison voltage, the ADF flag is set to "1."

**(14) Notes for the use of A-D conversion 1**

Note the following when using the analog input pins also for I/O port P4 functions:

- Even when P40/AIN4–P43/AIN7 are set to pins for analog input, they continue to function as P40–P43 I/O. Accordingly, when any of them are used as I/O port P4 and others are used as analog input pins, make sure to set the outputs of pins that are set for analog input to "1." Also, the port input function of the pin functions as an analog input is undefined.
- TALA instruction  
 When the TALA instruction is executed, the low-order 2 bits of register AD is transferred to the high-order 2 bits of register A, simultaneously, the low-order 2 bits of register A is "0."

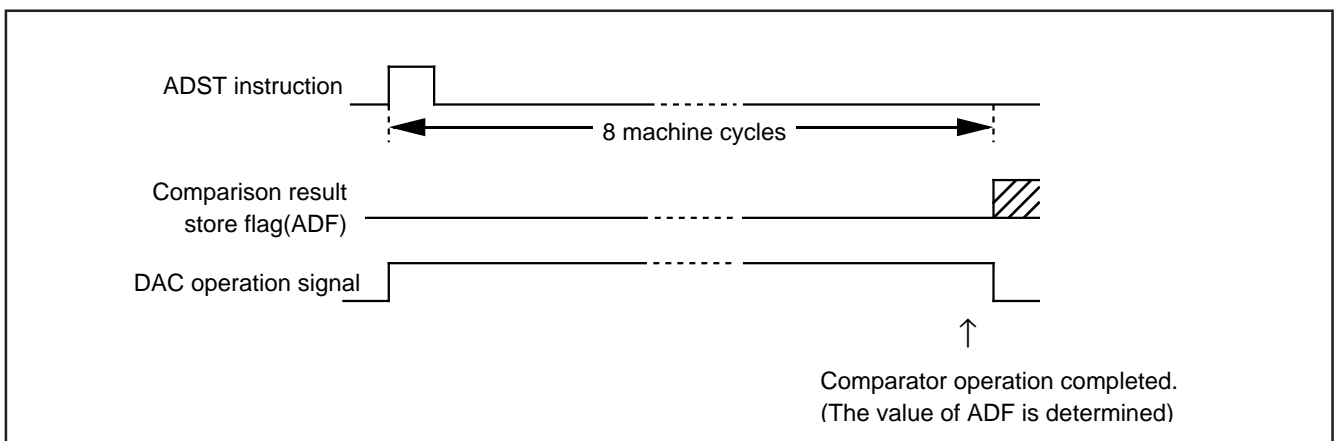

Fig. 29 Comparator operation timing chart

**(15) Notes for the use of A-D conversion 2**

Do not change the operating mode (both A-D conversion mode and comparator mode) of A-D converter with bit 3 of register Q2 while A-D converter is operating.

When the operating mode of A-D converter is changed from the comparator mode to A-D conversion mode with the bit 3 of register Q2, note the following;

- Clear bit 2 of register V2 to "0" to change the operating mode of the A-D converter from the comparator mode to A-D conversion mode with the bit 3 of register Q2.
- The A-D conversion completion flag (ADF) may be set when the operating mode of the A-D converter is changed from the comparator mode to the A-D conversion mode. Accordingly, set a value to register Q2, and execute the SNZAD instruction to clear the ADF flag.

**(16) Definition of A-D converter accuracy**

The A-D conversion accuracy is defined below (refer to Figure 30).

- Relative accuracy
  - ① Zero transition voltage ( $V_{0T}$ )  
 This means an analog input voltage when the actual A-D conversion output data changes from "0" to "1."
  - ② Full-scale transition voltage ( $V_{FST}$ )  
 This means an analog input voltage when the actual A-D conversion output data changes from "1023" to "1022."
  - ③ Linearity error  
 This means a deviation from the line between  $V_{0T}$  and  $V_{FST}$  of a converted value between  $V_{0T}$  and  $V_{FST}$ .
  - ④ Differential non-linearity error  
 This means a deviation from the input potential difference required to change a converter value between  $V_{0T}$  and  $V_{FST}$  by 1 LSB at the relative accuracy.
- Absolute accuracy  
 This means a deviation from the ideal characteristics between 0 to  $V_{DD}$  of actual A-D conversion characteristics.

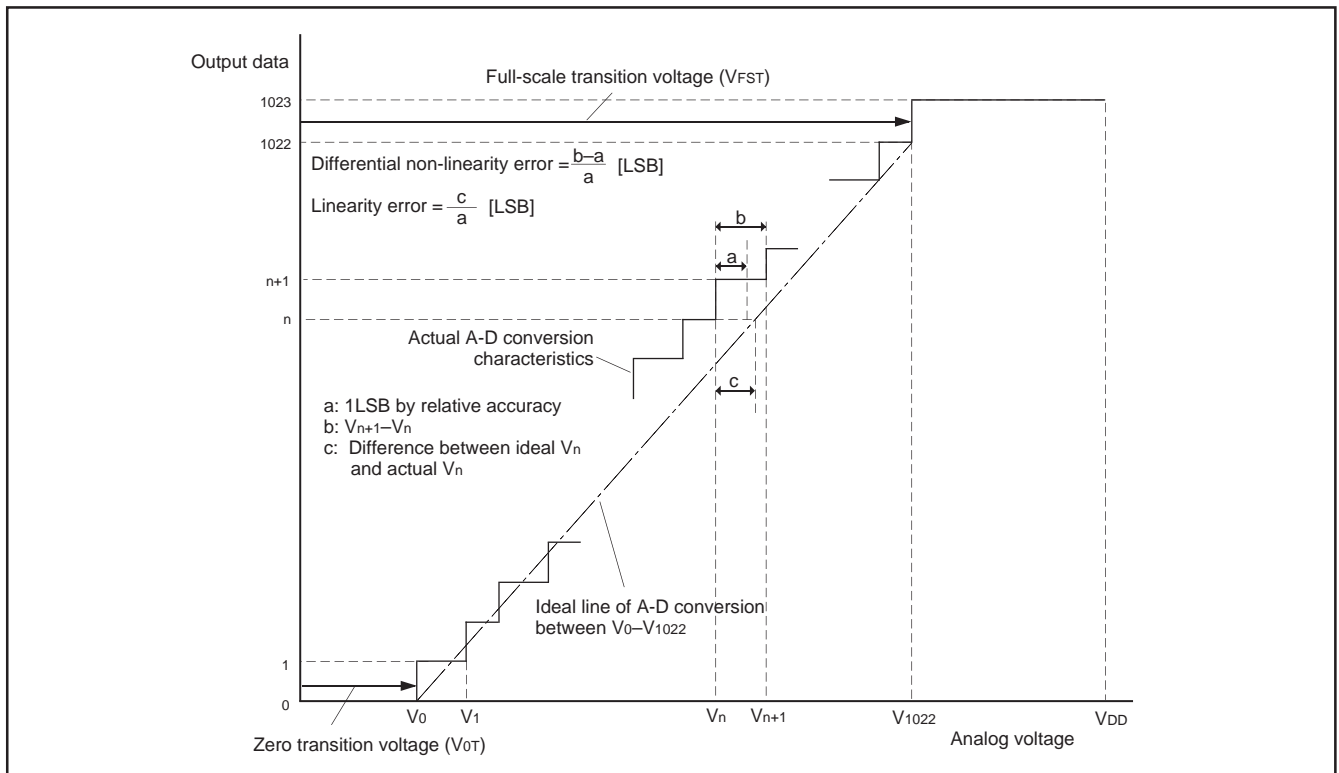

**Fig. 30 Definition of A-D conversion accuracy**

$V_n$ : Analog input voltage when the output data changes from "n" to "n+1" ( $n = 0$  to 1022)

• 1LSB at relative accuracy  $\rightarrow \frac{V_{FST}-V_{0T}}{1022}$  (V)

• 1LSB at absolute accuracy  $\rightarrow \frac{V_{DD}}{1024}$  (V)

**PRELIMINARY**  
 Notice: This is not a final specification.  
 Some parametric limits are subject to change.

**VOLTAGE COMPARATOR**

The 4513/4514 Group has 2 voltage comparator circuits that perform comparison of voltage between 2 pins. Table 17 shows the characteristics of this voltage comparison.

**Table 17 Voltage comparator characteristics**

Parameter	Characteristics
Voltage comparator function	2 circuits (CMP0, CMP1)
Input pin	CMP0-, CMP0+ (also used as AIN0, AIN1)
	CMP1-, CMP1+ (also used as AIN2, AIN3)
Supply voltage	3.0 V to 5.5 V
Input voltage	0.3 V <sub>DD</sub> to 0.7 V <sub>DD</sub>
Comparison check error	Typ. 20 mV, Max. 100 mV
Response time	Max. 20 μs

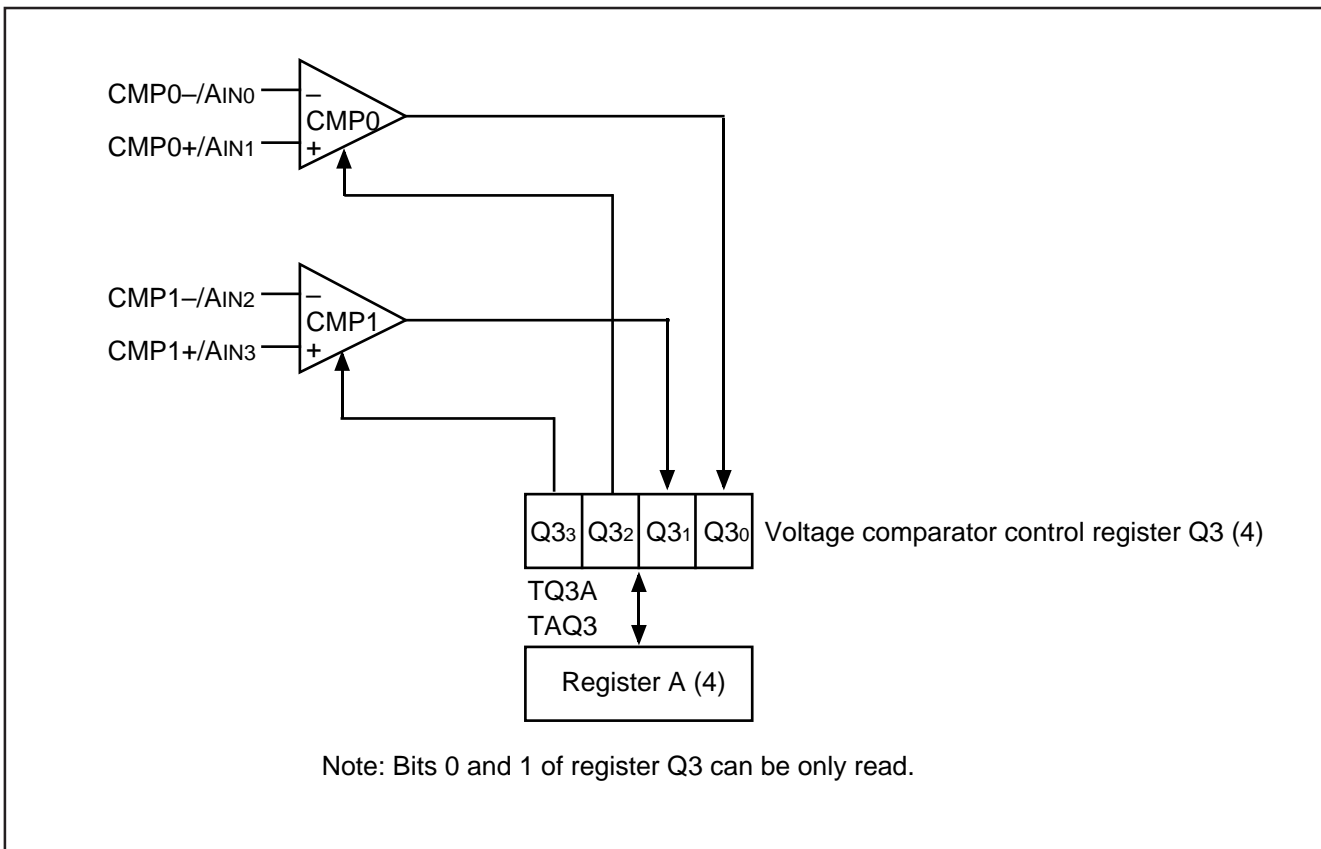

Fig. 31 Voltage comparator structure

**PRELIMINARY**  
 Notice: This is not a final specification.  
 Some parametric limits are subject to  
 change.

**Table 18 Voltage comparator control register Q3**

Voltage comparator control register Q3 (Note 2)		at reset : 00002		at RAM back-up : state retained	R/W
Q33	Voltage comparator (CMP1) control bit	0	Voltage comparator (CMP1) invalid		
		1	Voltage comparator (CMP1) valid		
Q32	Voltage comparator (CMP0) control bit	0	Voltage comparator (CMP0) invalid		
		1	Voltage comparator (CMP0) valid		
Q31	CMP1 comparison result store bit	0	CMP1- > CMP1+		
		1	CMP1- < CMP1+		
Q30	CMP0 comparison result store bit	0	CMP0- > CMP0+		
		1	CMP0- < CMP0+		

Notes 1: "R" represents read enabled, and "W" represents write enabled.  
 2: Bits 0 and 1 of register Q3 can be only read.

**(1) Voltage comparator control register Q3**

Register Q3 controls the function of the voltage comparator.  
 The function of the voltage comparator CMP0 becomes valid by setting bit 2 of register Q3 to "1," and becomes invalid by setting bit 2 of register Q3 to "0." The comparison result of the voltage comparator CMP0 is stored into bit 0 of register Q3.  
 The function of the voltage comparator CMP1 becomes valid by setting bit 3 of register Q3 to "1," and becomes invalid by setting bit 3 of register Q3 to "0." The comparison result of the voltage comparator CMP1 is stored into bit 1 of register Q3.

**(2) Operation description of voltage comparator**

The voltage comparator function becomes valid by setting each control bit of register Q3 to "1" and compares the voltage of the input pin. The comparison result is stored into each comparison result store bit of register Q3.  
 The comparison result is as follows;

- When CMP0- > CMP0+, Q30 = "0"  
 When CMP0- < CMP0+, Q30 = "1"
- When CMP1- > CMP1+, Q31 = "0"  
 When CMP1- < CMP1+, Q31 = "1"

**(3) Precautions**

When the voltage comparator is used, note the following;

- Voltage comparator function  
 When the voltage comparator function is valid with the voltage comparator control register Q3, it is operating even in the RAM back-up mode. Accordingly, be careful about such state because it causes the increase of the operation current in the RAM back-up mode.  
 In order to reduce the operation current in the RAM back-up mode, invalidate (bits 2 and 3 of register Q3 = "0") the voltage comparator function by software before the POF instruction is executed.  
 Also, while the voltage comparator function is valid, current is always consumed by voltage comparator. On the system required for the low-power dissipation, invalidate the voltage comparator by software when it is unused.
- Register Q3  
 Bits 0 and 1 of register Q3 can be only read. Note that they cannot be written.
- Reading the comparison result of voltage comparator  
 Read the voltage comparator comparison result from register Q3 after the voltage comparator response time (max. 20 μs) is passed from the voltage comparator function becomes valid.

**PRELIMINARY**  
 Notice: This is not a final specification.  
 Some parametric limits are subject to  
 change.

**RESET FUNCTION**

System reset is performed by applying "L" level to  $\overline{\text{RESET}}$  pin for 1 machine cycle or more when the following condition is satisfied; the value of supply voltage is the minimum value or more of the recommended operating conditions. Then when "H" level is applied to  $\overline{\text{RESET}}$  pin, software starts from address 0 in page 0.

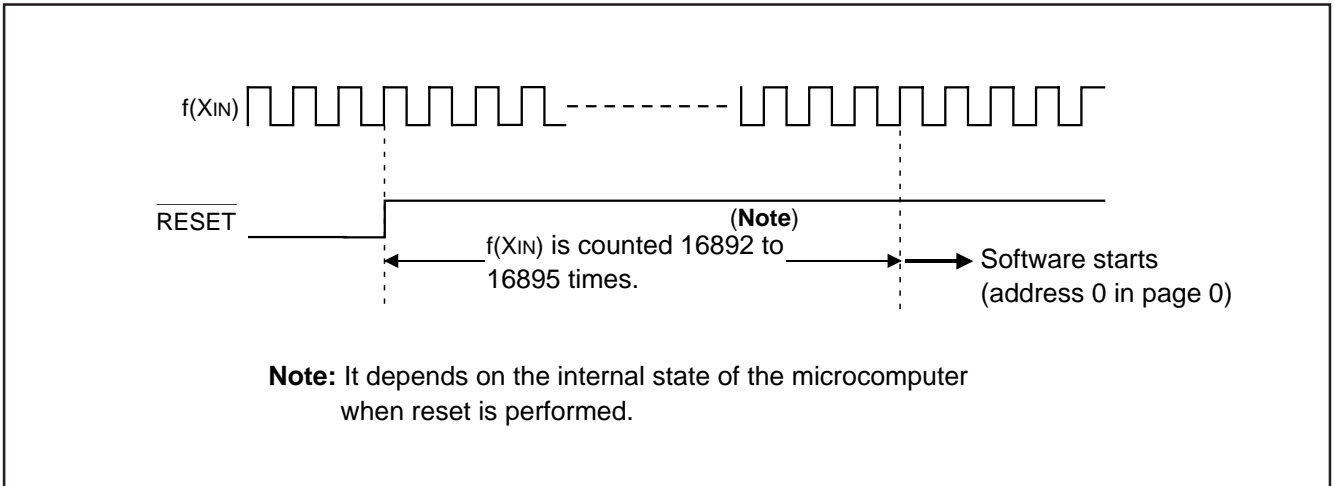

Fig. 32 Reset release timing

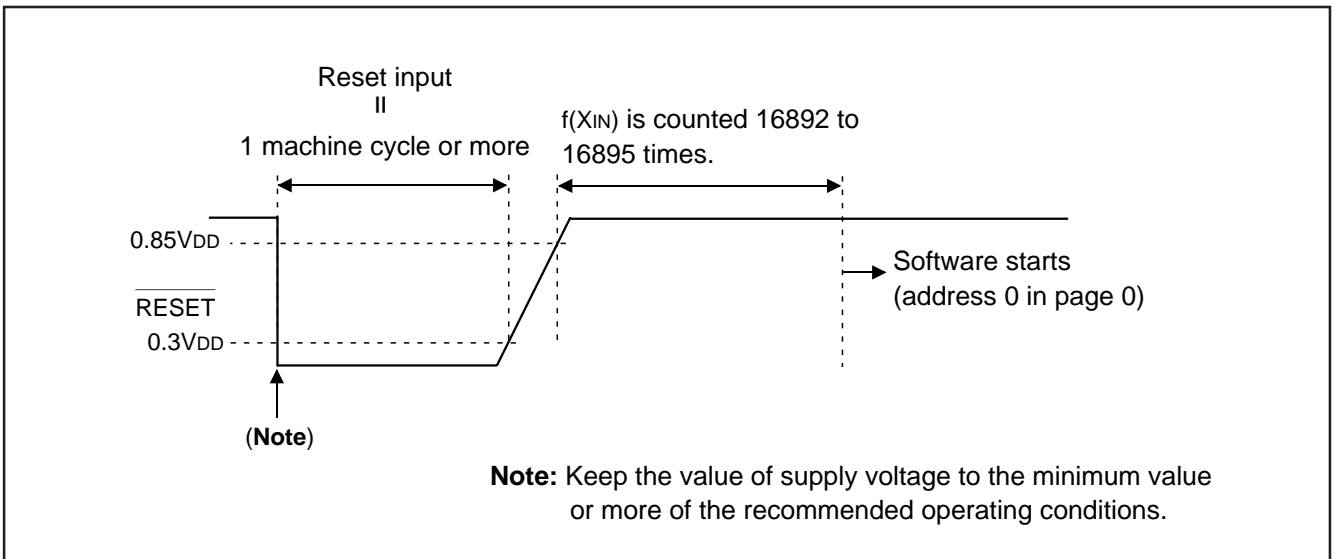

Fig. 33  $\overline{\text{RESET}}$  pin input waveform and reset operation

**PRELIMINARY**  
 Notice: This is not a final specification.  
 Some parametric limits are subject to change.

**(1) Power-on reset**

Reset can be performed automatically at power on (power-on reset) by connecting resistors, a diode, and a capacitor to  $\overline{\text{RESET}}$  pin. Connect  $\overline{\text{RESET}}$  pin and the external circuit at the shortest distance.

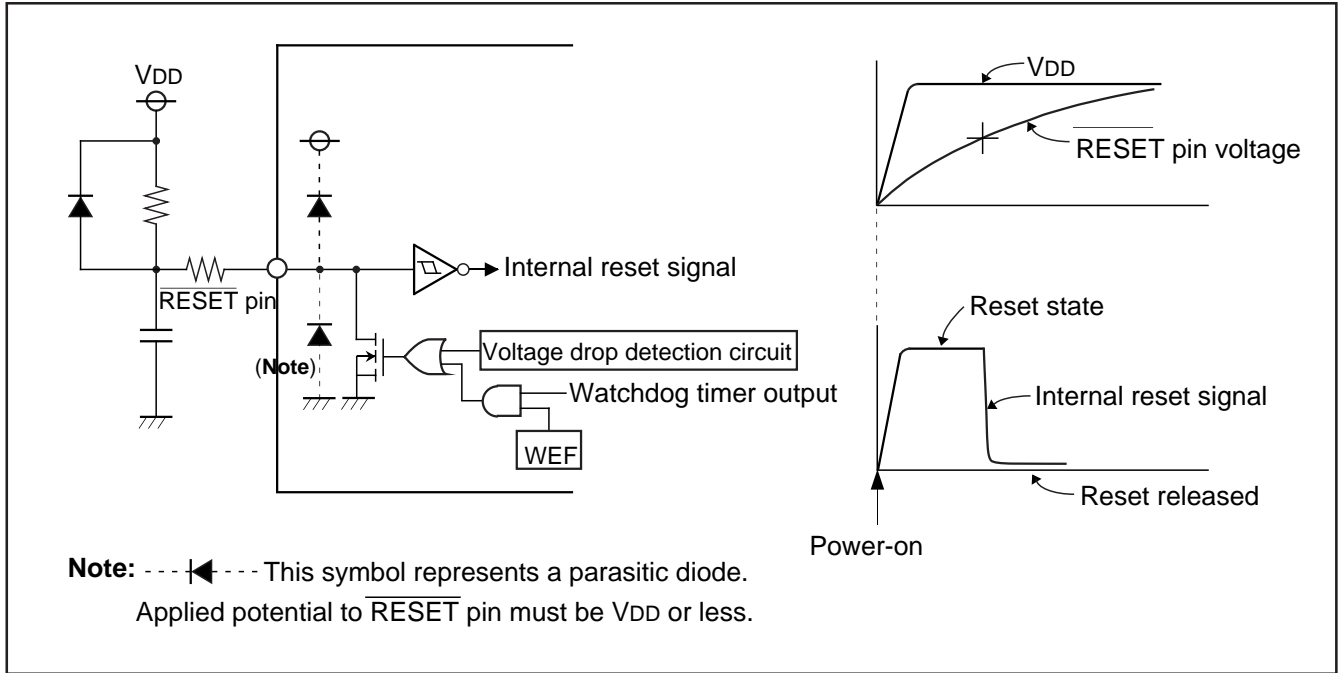

Fig. 34 Power-on reset circuit example

**(2) Internal state at reset**

Table 19 shows port state at reset, and Figure 35 shows internal state at reset (they are the same after system is released from reset). The contents of timers, registers, flags and RAM except shown in Figure 35 are undefined, so set the initial value to them.

Table 19 Port state at reset

Name	Function	State
D0–D5	D0–D5	High impedance (Note)
D6/CNTR0, D7/CNTR1	D6, D7	
P00–P03	P00–P03	High impedance (Notes 1, 2)
P10–P13	P10–P13	
P20/Sck, P21/SOUT, P22/SIN	P20–P22	High impedance
P30/INT0, P31/INT1	P30, P31	High impedance (Note 1)
P32, P33 (Note 4)	P32, P33	
P40/AIN4–P43/AIN7 (Note 4)	P40–P43	High impedance (Note 1)
P50–P53 (Note 4)	P50–P53	High impedance (Note 3)

- Notes 1: Output latch is set to "1."
- 2: Pull-up transistor is turned OFF.
- 3: After system is released from reset, port P5 is in the input mode. (Direction register FR0 = 00002)
- 4: The 4513 Group does not have these ports.



**PRELIMINARY**  
 Notice: This is not a final specification.  
 Some parametric limits are subject to  
 change.

• Program counter (PC) .....	0 0 0 0 0 0 0 0 0 0 0 0 0 0 0	
Address 0 in page 0 is set to program counter.		
• Interrupt enable flag (INTE) .....	0	(Interrupt disabled)
• Power down flag (P) .....	0	
• External 0 interrupt request flag (EXF0) .....	0	
• External 1 interrupt request flag (EXF1) .....	0	
• Interrupt control register V1 .....	0 0 0 0	(Interrupt disabled)
• Interrupt control register V2 .....	0 0 0 0	(Interrupt disabled)
• Interrupt control register I1 .....	0 0 0 0	
• Interrupt control register I2 .....	0 0 0 0	
• Timer 1 interrupt request flag (T1F) .....	0	
• Timer 2 interrupt request flag (T2F) .....	0	
• Timer 3 interrupt request flag (T3F) .....	0	
• Timer 4 interrupt request flag (T4F) .....	0	
• Watchdog timer flags (WDF1, WDF2) .....	0	
• Watchdog timer enable flag (WEF) .....	0	
• Timer control register W1 .....	0 0 0 0	(Prescaler and timer 1 stopped)
• Timer control register W2 .....	0 0 0 0	(Timer 2 stopped)
• Timer control register W3 .....	0 0 0 0	(Timer 3 stopped)
• Timer control register W4 .....	0 0 0 0	(Timer 4 stopped)
• Timer control register W6 .....	0 0 0 0	
• Clock control register MR .....	1 0 0 0	
• Serial I/O transmission/reception completion flag (SIOF) .....	0	
• Serial I/O mode register J1 .....	0 0 0 0	(External clock selected and serial I/O port not selected)
• Serial I/O register SI .....	X X X X X X X X	
• A-D conversion completion flag (ADF) .....	0	
• A-D control register Q1 .....	0 0 0 0	
• A-D control register Q2 .....	0 0 0 0	
• Voltage comparator control register Q3 .....	0 0 0 0	
• Successive comparison register AD .....	X X X X X X X X X X	
• Comparator register .....	X X X X X X X X	
• Key-on wakeup control register K0 .....	0 0 0 0	
• Pull-up control register PU0 .....	0 0 0 0	
• Direction register FR0 .....	0 0 0 0	(Port P5: input mode)
• Carry flag (CY) .....	0	
• Register A .....	0 0 0 0	
• Register B .....	0 0 0 0	
• Register D .....	X X X	
• Register E .....	X X X X X X X X	
• Register X .....	0 0 0 0	
• Register Y .....	0 0 0 0	
• Register Z .....	X X	
• Stack pointer (SP) .....	1 1 1	

“X” represents undefined.

Fig. 35 Internal state at reset

**VOLTAGE DROP DETECTION CIRCUIT**

The built-in voltage drop detection circuit is designed to detect a drop in voltage and to reset the microcomputer if the supply voltage drops below a set value.

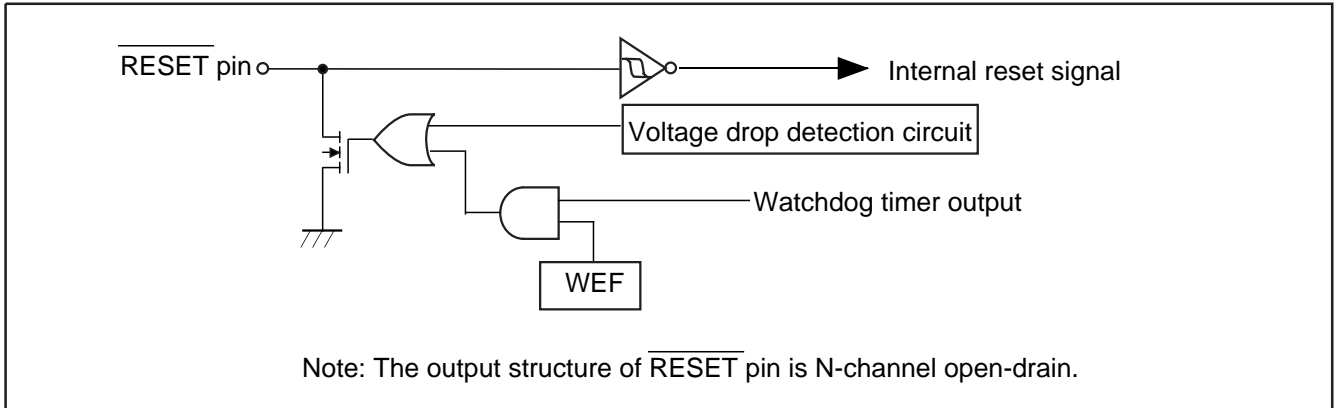

Fig. 36 Voltage drop detection reset circuit

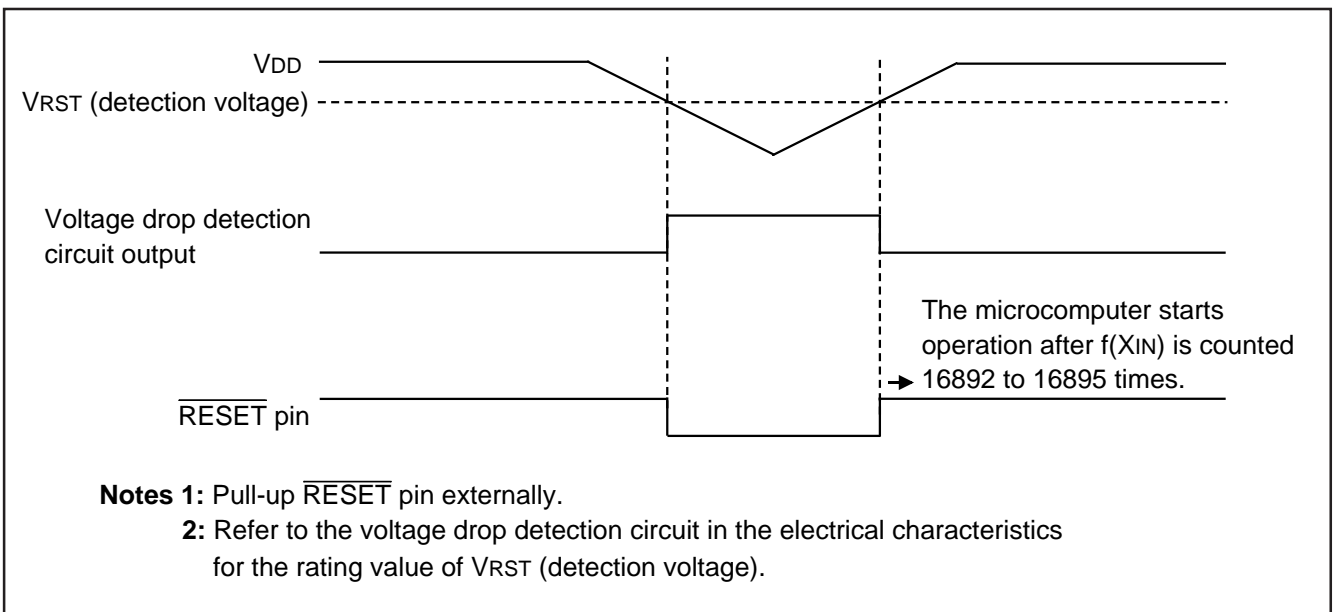

Fig. 37 Voltage drop detection circuit operation waveform

**PRELIMINARY**  
 Notice: This is not a final specification.  
 Some parametric limits are subject to  
 change.

**RAM BACK-UP MODE**

The 4513/4514 Group has the RAM back-up mode.

When the EPOF and POF instructions are executed continuously, system enters the RAM back-up state. The POF instruction is equal to the NOP instruction when the EPOF instruction is not executed before the POF instruction.

As oscillation stops retaining RAM, the function of reset circuit and states at RAM back-up mode, current dissipation can be reduced without losing the contents of RAM. Table 20 shows the function and states retained at RAM back-up. Figure 38 shows the state transition.

**(1) Identification of the start condition**

Warm start (return from the RAM back-up state) or cold start (return from the normal reset state) can be identified by examining the state of the power down flag (P) with the SNZP instruction.

**(2) Warm start condition**

When the external wakeup signal is input after the system enters the RAM back-up state by executing the EPOF and POF instructions continuously, the CPU starts executing the program from address 0 in page 0. In this case, the P flag is "1."

**(3) Cold start condition**

The CPU starts executing the program from address 0 in page 0 when;

- reset pulse is input to  $\overline{\text{RESET}}$  pin, or
- reset by watchdog timer is performed, or
- voltage drop detection circuit detects the voltage drop.

In this case, the P flag is "0."

**Table 20 Functions and states retained at RAM back-up**

Function	RAM back-up
Program counter (PC), registers A, B, carry flag (CY), stack pointer (SP) (Note 2)	X
Contents of RAM	O
Port level	O
Timer control register W1	X
Timer control registers W2 to W4, W6	O
Clock control register MR	X
Interrupt control registers V1, V2	X
Interrupt control registers I1, I2	O
Timer 1 function	X
Timer 2 function	(Note 3)
Timer 3 function	(Note 3)
Timer 4 function	(Note 3)
A-D conversion function	X
A-D control registers Q1, Q2	O
Voltage comparator function	O (Note 5)
Voltage comparator control register Q3	O
Serial I/O function	X
Serial I/O mode register J1	O
Pull-up control register PU0	O
Key-on wakeup control register K0	O
Direction register FR0	O
External 0 interrupt request flag (EXF0)	X
External 1 interrupt request flag (EXF1)	X
Timer 1 interrupt request flag (T1F)	X
Timer 2 interrupt request flag (T2F)	(Note 3)
Timer 3 interrupt request flag (T3F)	(Note 3)
Timer 4 interrupt request flag (T4F)	(Note 3)
Watchdog timer flags (WDF1, WDF2)	X (Note 4)
Watchdog timer enable flag (WEF)	X (Note 4)
16-bit timer (WDT)	X (Note 4)
A-D conversion completion flag (ADF)	X
Serial I/O transmission/reception completion flag (SIOF)	X
Interrupt enable flag (INTE)	X

- Notes 1: "O" represents that the function can be retained, and "X" represents that the function is initialized.  
 Registers and flags other than the above are undefined at RAM back-up, and set an initial value after returning.
- 2: The stack pointer (SP) points the level of the stack register and is initialized to "7" at RAM back-up.
- 3: The state of the timer is undefined.
- 4: Initialize the watchdog timer with the WRST instruction, and then execute the POF instruction.
- 5: The state is retained when the voltage comparator function is selected with the voltage comparator control register Q3.

**PRELIMINARY**  
 Notice: This is not a final specification.  
 Some parametric limits are subject to  
 change.

#### (4) Return signal

An external wakeup signal is used to return from the RAM back-up mode because the oscillation is stopped. Table 21 shows the return condition for each return source.

#### (5) Ports P0 and P1 control registers

- Key-on wakeup control register K0  
 Register K0 controls the ports P0 and P1 key-on wakeup function. Set the contents of this register through register A with the TK0A instruction. In addition, the TAK0 instruction can be used to transfer the contents of register K0 to register A.
- Pull-up control register PU0  
 Register PU0 controls the ON/OFF of the ports P0 and P1 pull-up transistor. Set the contents of this register through register A with the TPU0A instruction. In addition, the TAPU0 instruction can be used to transfer the contents of register PU0 to register A.

**Table 21 Return source and return condition**

	Return source	Return condition	Remarks
External wakeup signal	Ports P0, P1	Return by an external falling edge input ("H"→"L").	Set the port using the key-on wakeup function selected with register K0 to "H" level before going into the RAM back-up state because the port P0 shares the falling edge detection circuit with port P1.
	Port P30/INT0	Return by an external "H" level or "L" level input. The EXF0 flag is not set.	Select the return level ("L" level or "H" level) with the bit 2 of register I1 according to the external state before going into the RAM back-up state.
	Port P31/INT1	Return by an external "H" level or "L" level input. The EXF1 flag is not set.	Select the return level ("L" level or "H" level) with the bit 2 of register I2 according to the external state before going into the RAM back-up state.

**PRELIMINARY**  
 Notice: This is not a final specification.  
 Some parametric limits are subject to change.

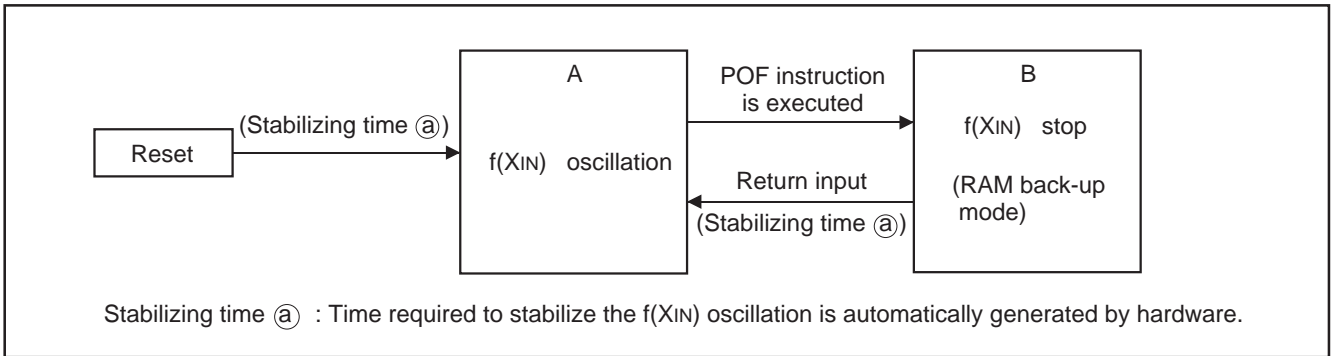

Fig. 38 State transition

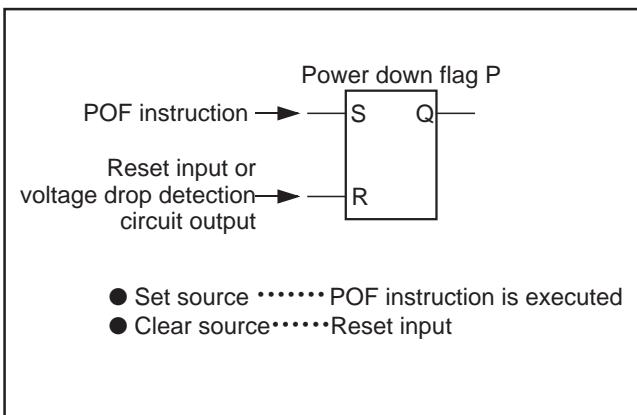

Fig. 39 Set source and clear source of the P flag

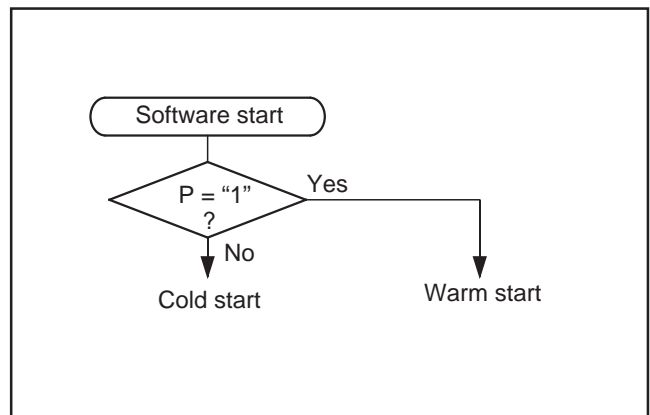

Fig. 40 Start condition identified example using the SNZP instruction

**PRELIMINARY**  
 Notice: This is not a final specification.  
 Some parametric limits are subject to  
 change.

**Table 22 Key-on wakeup control register, pull-up control register, and interrupt control register**

Key-on wakeup control register K0		at reset : 00002	at RAM back-up : state retained	R/W
K03	Pins P12 and P13 key-on wakeup control bit	0	Key-on wakeup not used	
		1	Key-on wakeup used	
K02	Pins P10 and P11 key-on wakeup control bit	0	Key-on wakeup not used	
		1	Key-on wakeup used	
K01	Pins P02 and P03 key-on wakeup control bit	0	Key-on wakeup not used	
		1	Key-on wakeup used	
K00	Pins P00 and P01 key-on wakeup control bit	0	Key-on wakeup not used	
		1	Key-on wakeup used	
Pull-up control register PU0		at reset : 00002	at RAM back-up : state retained	R/W
PU03	Pins P12 and P13 pull-up transistor control bit	0	Pull-up transistor OFF	
		1	Pull-up transistor ON	
PU02	Pins P10 and P11 pull-up transistor control bit	0	Pull-up transistor OFF	
		1	Pull-up transistor ON	
PU01	Pins P02 and P03 pull-up transistor control bit	0	Pull-up transistor OFF	
		1	Pull-up transistor ON	
PU00	Pins P00 and P01 pull-up transistor control bit	0	Pull-up transistor OFF	
		1	Pull-up transistor ON	
Interrupt control register I1		at reset : 00002	at RAM back-up : state retained	R/W
I13	Not used	0	This bit has no function, but read/write is enabled.	
		1		
I12	Interrupt valid waveform for INT0 pin/ return level selection bit (Note 2)	0	Falling waveform ("L" level of INT0 pin is recognized with the SNZI0 instruction)/"L" level	
		1	Rising waveform ("H" level of INT0 pin is recognized with the SNZI0 instruction)/"H" level	
I11	INT0 pin edge detection circuit control bit	0	One-sided edge detected	
		1	Both edges detected	
I10	INT0 pin timer 1 control enable bit	0	Disabled	
		1	Enabled	
Interrupt control register I2		at reset : 00002	at RAM back-up : state retained	R/W
I23	Not used	0	This bit has no function, but read/write is enabled.	
		1		
I22	Interrupt valid waveform for INT1 pin/ return level selection bit (Note 3)	0	Falling waveform ("L" level of INT1 pin is recognized with the SNZI1 instruction)/"L" level	
		1	Rising waveform ("H" level of INT1 pin is recognized with the SNZI1 instruction)/"H" level	
I21	INT1 pin edge detection circuit control bit	0	One-sided edge detected	
		1	Both edges detected	
I20	INT1 pin timer 3 control enable bit	0	Disabled	
		1	Enabled	

Notes 1: "R" represents read enabled, and "W" represents write enabled.

2: When the contents of I12 is changed, the external interrupt request flag EXF0 may be set. Accordingly, clear EXF0 flag with the SNZ0 instruction.

3: When the contents of I22 is changed, the external interrupt request flag EXF1 may be set. Accordingly, clear EXF1 flag with the SNZ1 instruction.

**PRELIMINARY**  
 Notice: This is not a final specification.  
 Some parametric limits are subject to change.

**CLOCK CONTROL**

The clock control circuit consists of the following circuits.

- System clock generating circuit
- Control circuit to stop the clock oscillation
- Control circuit to switch the middle-speed mode and high-speed mode
- Control circuit to return from the RAM back-up state

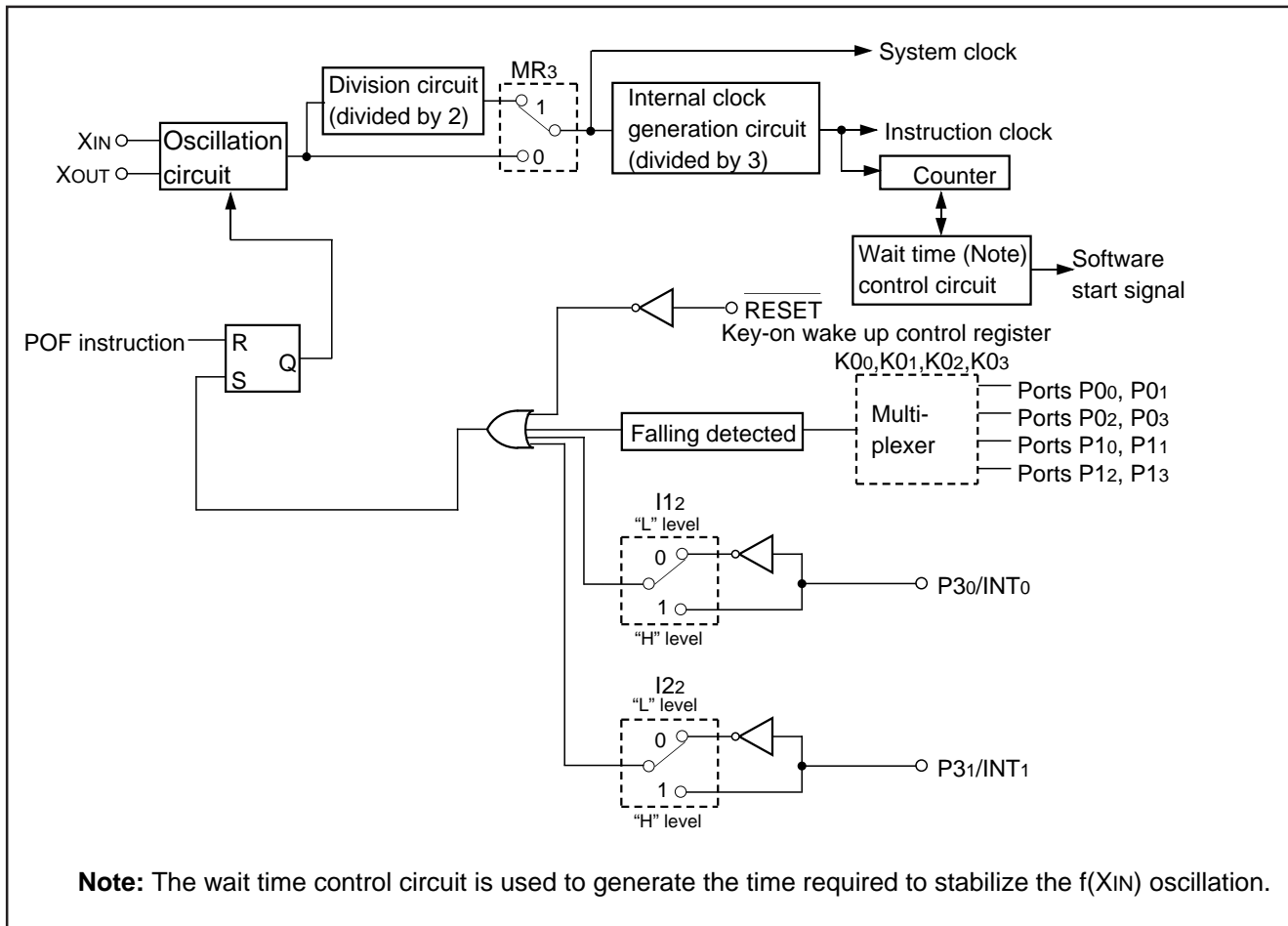

Fig. 41 Clock control circuit structure

Table 23 Clock control register MR

Clock control register MR		at reset : 10002	at RAM back-up : 10002	R/W
MR3	System clock selection bit	0	$f(X_{IN})$ (high-speed mode)	
		1	$f(X_{IN})/2$ (middle-speed mode)	
MR2	Not used	0	This bit has no function, but read/write is enabled.	
		1		
MR1	Not used	0	This bit has no function, but read/write is enabled.	
		1		
MR0	Not used	0	This bit has no function, but read/write is enabled.	
		1		

Note : "R" represents read enabled, and "W" represents write enabled.

**PRELIMINARY**  
 Notice: This is not a final specification.  
 Some parametric limits are subject to change.

Clock signal  $f(X_{IN})$  is obtained by externally connecting a ceramic resonator.

Connect this external circuit to pins  $X_{IN}$  and  $X_{OUT}$  at the shortest distance. A feedback resistor is built in between pins  $X_{IN}$  and  $X_{OUT}$ . When an external clock signal is input, connect the clock source to  $X_{IN}$  and leave  $X_{OUT}$  open. When using an external clock, the maximum value of external clock oscillating frequency is shown in Table 24.

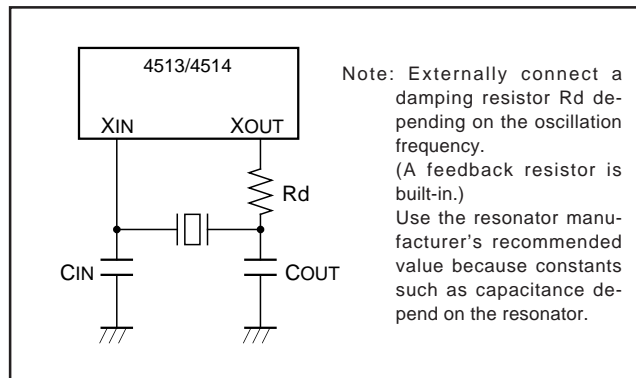

Fig. 42 Ceramic resonator external circuit

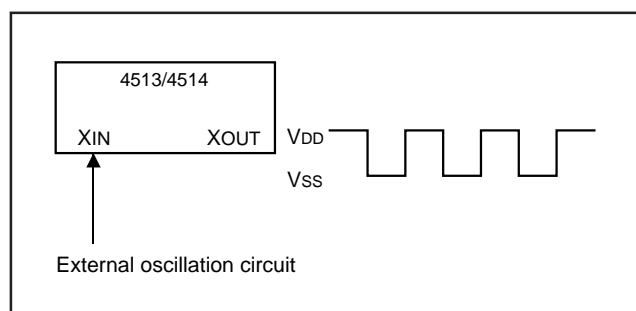

Fig. 43 External clock input circuit

Table 24 Maximum value of external clock oscillation frequency

		Supply voltage	Oscillation frequency (duty ratio)
Mask ROM version	Middle-speed mode	$V_{DD} = 2.0\text{ V to }5.5\text{ V}$	3.0 MHz (40 % to 60 %)
	High-speed mode	$V_{DD} = 4.0\text{ V to }5.5\text{ V}$	3.0 MHz (40 % to 60 %)
		$V_{DD} = 2.5\text{ V to }5.5\text{ V}$	1.0 MHz (40 % to 60 %)
		$V_{DD} = 2.0\text{ V to }5.5\text{ V}$	0.8 MHz (40 % to 60 %)
One Time PROM version	Middle-speed mode	$V_{DD} = 2.5\text{ V to }5.5\text{ V}$	3.0 MHz (40 % to 60 %)
	High-speed mode	$V_{DD} = 4.0\text{ V to }5.5\text{ V}$	3.0 MHz (40 % to 60 %)
		$V_{DD} = 2.5\text{ V to }5.5\text{ V}$	1.0 MHz (40 % to 60 %)

**ROM ORDERING METHOD**

Please submit the information described below when ordering Mask ROM.

- (1) Mask ROM Order Confirmation Form ..... 1
- (2) Data to be written into mask ROM ..... EPROM  
 (three sets containing the identical data)
- (3) Mark Specification Form ..... 1



**PRELIMINARY**  
 Notice: This is not a final specification.  
 Some parametric limits are subject to change.

**LIST OF PRECAUTIONS**

① **Noise and latch-up prevention**

Connect a capacitor on the following condition to prevent noise and latch-up;

- connect a bypass capacitor (approx. 0.1 μF) between pins VDD and VSS at the shortest distance,
- equalize its wiring in width and length, and
- use relatively thick wire.

In the One Time PROM version, CNVSS pin is also used as VPP pin. Accordingly, when using this pin, connect this pin to VSS through a resistor about 5 kΩ in series at the shortest distance.

② **Prescaler**

Stop the prescaler operation to change its frequency dividing ratio.

③ **Timer count source**

Stop timer 1, 2, 3, or 4 counting to change its count source.

④ **Reading the count value**

Stop timer 1, 2, 3, or 4 counting and then execute the TAB1, TAB2, TAB3, or TAB4 instruction to read its data.

⑤ **Writing to reload registers R1 and R3**

When writing data to reload registers R1 or R3 while timer 1 or timer 3 is operating, avoid a timing when timer 1 or timer 3 underflows.

⑥ **P30/INT0 pin**

When the interrupt valid waveform of the P30/INT0 pin is changed with the bit 2 of register I1 in software, be careful about the following notes.

- Clear the bit 0 of register V1 to "0" before the interrupt valid waveform of P30/INT0 pin is changed with the bit 2 of register I1 (refer to Figure 44①).
- Depending on the input state of the P30/INT0 pin, the external 0 interrupt request flag (EXF0) may be set when the interrupt valid waveform is changed. Accordingly, clear bit 2 of register I1, and execute the SNZ0 instruction to clear the EXF0 flag after executing at least one instruction (refer to Figure 44②).

```

:
LA 4 ; (XXX02)
TV1A ; The SNZ0 instruction is valid ..... ①
LA 4 ;
TI1A ; Interrupt valid waveform is changed
NOP ..... ②
SNZ0 ; The SNZ0 instruction is executed
NOP
:
X : this bit is not related to the setting of INT0 pin.
```

**Fig. 44 External 0 interrupt program example**

⑦ **P31/INT1 pin**

When the interrupt valid waveform of P31/INT1 pin is changed with the bit 2 of register I2 in software, be careful about the following notes.

- Clear the bit 1 of register V1 to "0" before the interrupt valid waveform of P31/INT1 pin is changed with the bit 2 of register I2 (refer to Figure 45③).
- Depending on the input state of the P31/INT1 pin, the external 1 interrupt request flag (EXF1) may be set when the interrupt valid waveform is changed. Accordingly, clear bit 2 of register I2 and execute the SNZ1 instruction to clear the EXF1 flag after executing at least one instruction (refer to Figure 45④).

```

:
LA 8 ; (XX0X2)
TV1A ; The SNZ1 instruction is valid ..... ③
LA 8 ;
TI2A ; Change of the interrupt valid waveform
NOP ..... ④
SNZ1 ; The SNZ1 instruction is executed
NOP
:
X : this bit is not related to the setting of INT1.
```

**Fig. 45 External 1 interrupt program example**

⑧ **One Time PROM version**

The operating power voltage of the One Time PROM version is 2.5 V to 5.5 V.

⑨ **Multifunction**

The input of D6, D7, P20–P22, I/O of P30 and P31, input of CMP0-, CMP0+, CMP1-, CMP1+, and I/O of P40–P43 can be used even when CNTR0, CNTR1, SCK, SOUT, SIN, INT0, INT1, AIN0–AIN3 and AIN4–AIN7 are selected.

**PRELIMINARY**  
 Notice: This is not a final specification.  
 Some parametric limits are subject to change.

⑩ A-D converter-1

When the operating mode of the A-D converter is changed from the comparator mode to the A-D conversion mode with the bit 3 of register Q2 in a program, be careful about the following notes.

- Clear the bit 2 of register V2 to "0" to change the operating mode of the A-D converter from the comparator mode to the A-D conversion mode with the bit 3 of register Q2 (refer to Figure 46⑤).
- The A-D conversion completion flag (ADF) may be set when the operating mode of the A-D converter is changed from the comparator mode to the A-D conversion mode. Accordingly, set a value to register Q2, and execute the SNZAD instruction to clear the ADF flag.

Do not change the operating mode (both A-D conversion mode and comparator mode) of A-D converter with the bit 3 of register Q2 during operating the A-D converter.

```

:
LA 8 ; (X0XX2)
TV2A ; The SNZAD instruction is valid .....⑤
LA 0 ; (0XXX2)
TQ2A ; Change of the operating mode of the A-D
      ; converter from the comparator mode to the
      ; A-D conversion mode

SNZAD
NOP
:
X: this bit is not related to the change of the
    operating mode of the A-D conversion.
    
```

Fig. 46 A-D converter operating mode program example

⑪ A-D converter-2

Each analog input pin is equipped with a capacitor which is used to compare the analog voltage. Accordingly, when the analog voltage is input from the circuit with high-impedance and, charge/discharge noise is generated and the sufficient A-D accuracy may not be obtained. Therefore, reduce the impedance or, connect a capacitor (0.01 μF to 1 μF) to analog input pins (Figure 47).

When the overvoltage applied to the A-D conversion circuit may occur, connect an external circuit in order to keep the voltage within the rated range as shown the Figure 48. In addition, test the application products sufficiently.

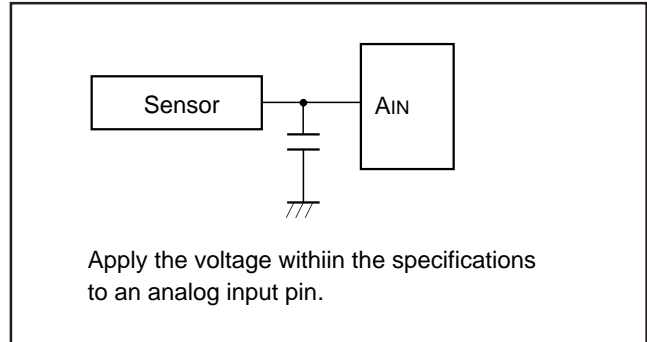

Apply the voltage within the specifications to an analog input pin.

Fig. 47 Analog input external circuit example-1

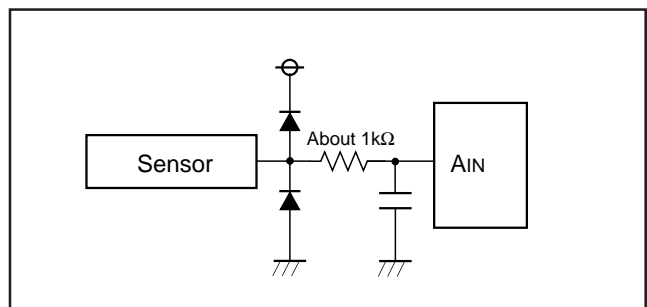

Fig. 48 Analog input external circuit example-2

⑫ POF instruction

Execute the POF instruction immediately after executing the EPOF instruction to enter the RAM back-up.

Note that system cannot enter the RAM back-up state when executing only the POF instruction.

Be sure to disable interrupts by executing the DI instruction before executing the EPOF instruction.

⑬ Analog input pins

Note the following when using the analog input pins also for I/O port P4 functions:

- Even when P40/AIN4–P43/AIN7 are set to pins for analog input, they continue to function as P40–P43 I/O. Accordingly, when any of them are used as I/O port P4 and others are used as analog input pins, make sure to set the outputs of pins that are set for analog input to "1." Also, the port input function of the pin functions as an analog input is undefined.
- TALA instruction  
 When the TALA instruction is executed, the low-order 2 bits of register AD is transferred to the high-order 2 bits of register A, simultaneously, the low-order 2 bits of register A is "0."

⑭ Program counter

Make sure that the PCH does not specify after the last page of the built-in ROM.

⑮ Port P3

In the 4513 Group, when the IAP3 instruction is executed, note that the high-order 2 bits of register A is undefined.

**PRELIMINARY**  
Notice: This is not a final specification.  
Some parametric limits are subject to  
change.

#### ⑯ Voltage comparator function

When the voltage comparator function is valid with the voltage comparator control register Q3, it is operating even in the RAM back-up mode. Accordingly, be careful about such state because it causes the increase of the operation current in the RAM back-up mode.

In order to reduce the operation current in the RAM back-up mode, invalidate (bits 2 and 3 of register Q3 = "0") the voltage comparator function by software before the POF instruction is executed.

Also, while the voltage comparator function is valid, current is always consumed by voltage comparator. On the system required for the low-power dissipation, invalidate the voltage comparator when it is unused by software.

#### ⑰ Register Q3

Bits 0 and 1 of register Q3 can be only read. Note that they cannot be written.

#### ⑱ Reading the comparison result of voltage comparator

Read the voltage comparator comparison result from register Q3 after the voltage comparator response time (max. 20  $\mu$ s) is passed from the voltage comparator function become valid.

**PRELIMINARY**  
 Notice: This is not a final specification.  
 Some parametric limits are subject to  
 change.

**SYMBOL**

The symbols shown below are used in the following instruction function table and instruction list.

Symbol	Contents	Symbol	Contents
A	Register A (4 bits)	T1F	Timer 1 interrupt request flag
B	Register B (4 bits)	T2F	Timer 2 interrupt request flag
DR	Register D (3 bits)	T3F	Timer 3 interrupt request flag
E	Register E (8 bits)	T4F	Timer 4 interrupt request flag
Q1	A-D control register Q1 (4 bits)	WDF1	Watchdog timer flag
Q2	A-D control register Q2 (4 bits)	WEF	Watchdog timer enable flag
Q3	Voltage comparator control register Q3 (4 bits)	INTE	Interrupt enable flag
AD	Successive comparison register AD (10 bits)	EXF0	External 0 interrupt request flag
J1	Serial I/O mode register J1 (4 bits)	EXF1	External 1 interrupt request flag
SI	Serial I/O register SI (8 bits)	P	Power down flag
V1	Interrupt control register V1 (4 bits)	ADF	A-D conversion completion flag
V2	Interrupt control register V2 (4 bits)	SIOF	Serial I/O transmission/reception completion flag
I1	Interrupt control register I1 (4 bits)		
I2	Interrupt control register I2 (4 bits)	D	Port D (8 bits)
W1	Timer control register W1 (4 bits)	P0	Port P0 (4 bits)
W2	Timer control register W2 (4 bits)	P1	Port P1 (4 bits)
W3	Timer control register W3 (4 bits)	P2	Port P2 (3 bits)
W4	Timer control register W4 (4 bits)	P3	Port P3 (4 bits)
W6	Timer control register W6 (4 bits)	P4	Port P4 (4 bits)
MR	Clock control register MR (4 bits)	P5	Port P5 (4 bits)
K0	Key-on wakeup control register K0 (4 bits)		
PU0	Pull-up control register PU0 (4 bits)	x	Hexadecimal variable
FR0	Direction register FR0 (4 bits)	y	Hexadecimal variable
X	Register X (4 bits)	z	Hexadecimal variable
Y	Register Y (4 bits)	p	Hexadecimal variable
Z	Register Z (2 bits)	n	Hexadecimal constant
DP	Data pointer (10 bits) (It consists of registers X, Y, and Z)	i	Hexadecimal constant
PC	Program counter (14 bits)	j	Hexadecimal constant
PC <sub>H</sub>	High-order 7 bits of program counter	A3A2A1A0	Binary notation of hexadecimal variable A (same for others)
PC <sub>L</sub>	Low-order 7 bits of program counter		
SK	Stack register (14 bits X 8)	←	Direction of data movement
SP	Stack pointer (3 bits)	↔	Data exchange between a register and memory
CY	Carry flag	?	Decision of state shown before “?”
R1	Timer 1 reload register	( )	Contents of registers and memories
R2	Timer 2 reload register	—	Negate, Flag unchanged after executing instruction
R3	Timer 3 reload register	M(DP)	RAM address pointed by the data pointer
R4	Timer 4 reload register	a	Label indicating address a6 a5 a4 a3 a2 a1 a0
T1	Timer 1	p, a	Label indicating address a6 a5 a4 a3 a2 a1 a0 in page p5 p4 p3 p2 p1 p0
T2	Timer 2	C	Hex. C + Hex. number x (also same for others)
T3	Timer 3	+	
T4	Timer 4	x	

Note : The 4513/4514 Group just invalidates the next instruction when a skip is performed. The contents of program counter is not increased by 2. Accordingly, the number of cycles does not change even if skip is not performed. However, the cycle count becomes “1” if the TABP p, RT, or RTS instruction is skipped.

**PRELIMINARY**  
 Notice: This is not a final specification.  
 Some parametric limits are subject to  
 change.

**LIST OF INSTRUCTION FUNCTION**

Grouping	Mnemonic	Function	Grouping	Mnemonic	Function	Grouping	Mnemonic	Function	
Register to register transfer	TAB	$(A) \leftarrow (B)$	RAM to register transfer	XAMI j	$(A) \leftarrow \rightarrow (M(DP))$ $(X) \leftarrow (X)EXOR(j)$ j = 0 to 15 $(Y) \leftarrow (Y) + 1$	Bit operation	SB j	$(M_j(DP)) \leftarrow 1$ j = 0 to 3	
	TBA	$(B) \leftarrow (A)$		TMA j	$(M(DP)) \leftarrow (A)$ $(X) \leftarrow (X)EXOR(j)$ j = 0 to 15		RB j	$(M_j(DP)) \leftarrow 0$ j = 0 to 3	
	TAY	$(A) \leftarrow (Y)$		Arithmetic operation	LA n		$(A) \leftarrow n$ n = 0 to 15	Comparison operation	SEAM
	TYA	$(Y) \leftarrow (A)$			TABP p	$(SP) \leftarrow (SP) + 1$ $(SK(SP)) \leftarrow (PC)$ $(PCH) \leftarrow p$ $(PCL) \leftarrow (DR_2-DR_0, A_3-A_0)$ $(B) \leftarrow (ROM(PC))_{7-4}$ $(A) \leftarrow (ROM(PC))_{3-0}$ $(PC) \leftarrow (SK(SP))$ $(SP) \leftarrow (SP) - 1$	SEA n		$(A) = n ?$ n = 0 to 15
	TEAB	$(E_7-E_4) \leftarrow (B)$ $(E_3-E_0) \leftarrow (A)$			AM	$(A) \leftarrow (A) + (M(DP))$	Branch operation	B a	$(PCL) \leftarrow a_6-a_0$
	TABE	$(B) \leftarrow (E_7-E_4)$ $(A) \leftarrow (E_3-E_0)$			AMC	$(A) \leftarrow (A) + (M(DP)) + (CY)$ $(CY) \leftarrow \text{Carry}$		BL p, a	$(PCH) \leftarrow p$ $(PCL) \leftarrow a_6-a_0$
	TDA	$(DR_2-DR_0) \leftarrow (A_2-A_0)$			A n	$(A) \leftarrow (A) + n$ n = 0 to 15		BLA p	$(PCH) \leftarrow p$ $(PCL) \leftarrow (DR_2-DR_0, A_3-A_0)$
	TAD	$(A_2-A_0) \leftarrow (DR_2-DR_0)$ $(A_3) \leftarrow 0$			AND	$(A) \leftarrow (A) AND (M(DP))$	Subroutine operation	BM a	$(SP) \leftarrow (SP) + 1$ $(SK(SP)) \leftarrow (PC)$ $(PCH) \leftarrow 2$ $(PCL) \leftarrow a_6-a_0$
	TAZ	$(A_1, A_0) \leftarrow (Z_1, Z_0)$ $(A_3, A_2) \leftarrow 0$			OR	$(A) \leftarrow (A) OR (M(DP))$		BML p, a	$(SP) \leftarrow (SP) + 1$ $(SK(SP)) \leftarrow (PC)$ $(PCH) \leftarrow p$ $(PCL) \leftarrow a_6-a_0$
	TAX	$(A) \leftarrow (X)$		SC	$(CY) \leftarrow 1$	BMLA p		$(SP) \leftarrow (SP) + 1$ $(SK(SP)) \leftarrow (PC)$ $(PCH) \leftarrow p$ $(PCL) \leftarrow (DR_2-DR_0, A_3-A_0)$	
TASP	$(A_2-A_0) \leftarrow (SP_2-SP_0)$ $(A_3) \leftarrow 0$	RC	$(CY) \leftarrow 0$	Return operation	RTI	$(PC) \leftarrow (SK(SP))$ $(SP) \leftarrow (SP) - 1$			
RAM addresses	LXY x, y	$(X) \leftarrow x, x = 0 \text{ to } 15$ $(Y) \leftarrow y, y = 0 \text{ to } 15$	SZC		$(CY) = 0 ?$	RT	$(PC) \leftarrow (SK(SP))$ $(SP) \leftarrow (SP) - 1$		
	LZ z	$(Z) \leftarrow z, z = 0 \text{ to } 3$	CMA		$(A) \leftarrow (\bar{A})$	RTS	$(PC) \leftarrow (SK(SP))$ $(SP) \leftarrow (SP) - 1$		
	INY	$(Y) \leftarrow (Y) + 1$	RAR	$\rightarrow \boxed{CY} \rightarrow \boxed{A_3A_2A_1A_0}$					
	DEY	$(Y) \leftarrow (Y) - 1$							
RAM to register transfer	TAM j	$(A) \leftarrow (M(DP))$ $(X) \leftarrow (X)EXOR(j)$ j = 0 to 15							
	XAM j	$(A) \leftarrow \rightarrow (M(DP))$ $(X) \leftarrow (X)EXOR(j)$ j = 0 to 15							
	XAMD j	$(A) \leftarrow \rightarrow (M(DP))$ $(X) \leftarrow (X)EXOR(j)$ j = 0 to 15 $(Y) \leftarrow (Y) - 1$							

**PRELIMINARY**  
 Notice: This is not a final specification.  
 Some parametric limits are subject to  
 change.

**LIST OF INSTRUCTION FUNCTION (continued)**

Group- ing	Mnemonic	Function	Group- ing	Mnemonic	Function	Group- ing	Mnemonic	Function
Interrupt operation	DI	(INTE) ← 0	Timer operation	TAW4	(A) ← (W4)	Timer operation	SNZT1	(T1F) = 1 ? After skipping (T1F) ← 0
	EI	(INTE) ← 1		TW4A	(W4) ← (A)		SNZT2	(T2F) = 1 ? After skipping (T2F) ← 0
	SNZ0	(EXF0) = 1 ? After skipping (EXF0) ← 0		TAW6	(A) ← (W6)		SNZT3	(T3F) = 1 ? After skipping (T3F) ← 0
	SNZ1	(EXF1) = 1 ? After skipping (EXF1) ← 0		TW6A	(W6) ← (A)		SNZT4	(T4F) = 1 ? After skipping (T4F) ← 0
	SNZI0	I12 = 1 : (INT0) = "H" ? I12 = 0 : (INT0) = "L" ?		TAB1	(B) ← (T17-T14) (A) ← (T13-T10)	Input/Output operation	IAP0	(A) ← (P0)
	SNZI1	I22 = 1 : (INT1) = "H" ? I22 = 0 : (INT1) = "L" ?		T1AB	(R17-R14) ← (B) (T17-T14) ← (B) (R13-R10) ← (A) (T13-T10) ← (A)		OP0A	(P0) ← (A)
	TAV1	(A) ← (V1)		TAB2	(B) ← (T27-T24) (A) ← (T23-T20)		IAP1	(A) ← (P1)
	TV1A	(V1) ← (A)		T2AB	(R27-R24) ← (B) (T27-T24) ← (B) (R23-R20) ← (A) (T23-T20) ← (A)		OP1A	(P1) ← (A)
	TAV2	(A) ← (V2)		TAB3	(B) ← (T37-T34) (A) ← (T33-T30)		IAP2	(A2-A0) ← (P22-P20) (A3) ← 0
	TV2A	(V2) ← (A)		T3AB	(R37-R34) ← (B) (T37-T34) ← (B) (R33-R30) ← (A) (T33-T30) ← (A)		IAP3	(A) ← (P3)
	TAI1	(A) ← (I1)		TAB4	(B) ← (T47-T44) (A) ← (T43-T40)		OP3A	(P3) ← (A)
	TI1A	(I1) ← (A)		T4AB	(R47-R44) ← (B) (T47-T44) ← (B) (R43-R40) ← (A) (T43-T40) ← (A)		IAP4*	(A) ← (P4)
	TAI2	(A) ← (I2)		TR1AB	(R17-R14) ← (B) (R13-R10) ← (A)		OP4A*	(P4) ← (A)
	TI2A	(I2) ← (A)		TR3AB	(R37-R34) ← (B) (R33-R30) ← (A)		IAP5*	(A) ← (P5)
Timer operation	TAW1	(A) ← (W1)			OP5A*	(P5) ← (A)		
	TW1A	(W1) ← (A)			CLD	(D) ← 1		
	TAW2	(A) ← (W2)			RD	(D(Y)) ← 0 (Y) = 0 to 7		
	TW2A	(W2) ← (A)			SD	(D(Y)) ← 1 (Y) = 0 to 7		
	TAW3	(A) ← (W3)			SZD	(D(Y)) = 0 ? (Y) = 0 to 7		
	TW3A	(W3) ← (A)						

\*: The 4513 Group does not have these instructions.

**PRELIMINARY**  
 Notice: This is not a final specification.  
 Some parametric limits are subject to  
 change.

**LIST OF INSTRUCTION FUNCTION (continued)**

Group- ing	Mnemonic	Function	Group- ing	Mnemonic	Function	
Input/Output operation	TK0A	(K0) ← (A)	A-D conversion operation	TABAD	(A) ← (AD5-AD2) (B) ← (AD9-AD6) However, in the com- parator mode, (A) ← (AD3-AD0) (B) ← (AD7-AD4)	
	TAK0	(A) ← (K0)		TALA	(A) ← (AD1, AD0, 0, 0)	
	TPU0A	(PU0) ← (A)		TADAB	(AD3-AD0) ← (A) (AD7-AD4) ← (B)	
	TAPU0	(A) ← (PU0)		TAQ1	(A) ← (Q1)	
	TFR0A*	(FR0) ← (A)		TQ1A	(Q1) ← (A)	
Serial I/O control operation	TABSI	(A) ← (SI3-SI0) (B) ← (SI7-SI4)		ADST	(ADF) ← 0 A-D conversion starting	
	TSIAB	(SI3-SI0) ← (A) (SI7-SI4) ← (B)		SNZAD	(ADF) = 1 ? After skipping (ADF) ← 0	
	TAJ1	(A) ← (J1)		TAQ2	(A) ← (Q2)	
	TJ1A	(J1) ← (A)		TQ2A	(Q2) ← (A)	
	SST	(SIOF) ← 0 Serial I/O starting				
	SNZSI	(SIOF) = 1 ? After skipping (SIOF) ← 0				
				Other operation	NOP	(PC) ← (PC) + 1
					POF	RAM back-up
					EPOF	POF instruction valid
					SNZP	(P) = 1 ?
			WRST		(WDF1) ← 0, (WEF) ← 1	
			TAMR		(A) ← (MR)	
			TMRA		(MR) ← (A)	
			TAQ3		(A) ← (Q3)	
			TQ3A		(Q33, Q32) ← (A3, A2) (Q31) ← (CMP1 com- parison result) (Q30) ← (CMP0 com- parison result)	

\*: The 4513 Group does not have these instructions.

**PRELIMINARY**  
 Notice: This is not a final specification.  
 Some parametric limits are subject to  
 change.

**INSTRUCTION CODE TABLE (for 4513 Group)**

D3-D0	D9-D4 Hex. notation	D9-D4																010000		011000	
		00	01	02	03	04	05	06	07	08	09	0A	0B	0C	0D	0E	0F	10-17	18-1F		
0000	0	NOP	BLA	SZB 0	BMLA	-	TASP	A 0	LA 0	TABP 0	TABP 16***	TABP 32**	TABP 48*	BML	BML***	BL	BL***	BM	B		
0001	1	-	CLD	SZB 1	-	-	TAD	A 1	LA 1	TABP 1	TABP 17***	TABP 33**	TABP 49*	BML	BML***	BL	BL***	BM	B		
0010	2	POF	-	SZB 2	-	-	TAX	A 2	LA 2	TABP 2	TABP 18***	TABP 34**	TABP 50*	BML	BML***	BL	BL***	BM	B		
0011	3	SNZP	INY	SZB 3	-	-	TAZ	A 3	LA 3	TABP 3	TABP 19***	TABP 35**	TABP 51*	BML	BML***	BL	BL***	BM	B		
0100	4	DI	RD	SZD	-	RT	TAV1	A 4	LA 4	TABP 4	TABP 20***	TABP 36**	TABP 52*	BML	BML***	BL	BL***	BM	B		
0101	5	EI	SD	SEAn	-	RTS	TAV2	A 5	LA 5	TABP 5	TABP 21***	TABP 37**	TABP 53*	BML	BML***	BL	BL***	BM	B		
0110	6	RC	-	SEAM	-	RTI	-	A 6	LA 6	TABP 6	TABP 22***	TABP 38**	TABP 54*	BML	BML***	BL	BL***	BM	B		
0111	7	SC	DEY	-	-	-	-	A 7	LA 7	TABP 7	TABP 23***	TABP 39**	TABP 55*	BML	BML***	BL	BL***	BM	B		
1000	8	-	AND	-	SNZ0	LZ 0	-	A 8	LA 8	TABP 8	TABP 24***	TABP 40**	TABP 56*	BML	BML***	BL	BL***	BM	B		
1001	9	-	OR	TDA	SNZ1	LZ 1	-	A 9	LA 9	TABP 9	TABP 25***	TABP 41**	TABP 57*	BML	BML***	BL	BL***	BM	B		
1010	A	AM	TEAB	TABE	SNZI0	LZ 2	-	A 10	LA 10	TABP 10	TABP 26***	TABP 42**	TABP 58*	BML	BML***	BL	BL***	BM	B		
1011	B	AMC	-	-	SNZI1	LZ 3	EPOF	A 11	LA 11	TABP 11	TABP 27***	TABP 43**	TABP 59*	BML	BML***	BL	BL***	BM	B		
1100	C	TYA	CMA	-	-	RB 0	SB 0	A 12	LA 12	TABP 12	TABP 28***	TABP 44**	TABP 60*	BML	BML***	BL	BL***	BM	B		
1101	D	-	RAR	-	-	RB 1	SB 1	A 13	LA 13	TABP 13	TABP 29***	TABP 45**	TABP 61*	BML	BML***	BL	BL***	BM	B		
1110	E	TBA	TAB	-	TV2A	RB 2	SB 2	A 14	LA 14	TABP 14	TABP 30***	TABP 46**	TABP 62*	BML	BML***	BL	BL***	BM	B		
1111	F	-	TAY	SZC	TV1A	RB 3	SB 3	A 15	LA 15	TABP 15	TABP 31***	TABP 47**	TABP 63*	BML	BML***	BL	BL***	BM	B		

The above table shows the relationship between machine language codes and machine language instructions. D3-D0 show the low-order 4 bits of the machine language code, and D9-D4 show the high-order 6 bits of the machine language code. The hexadecimal representation of the code is also provided. There are one-word instructions and two-word instructions, but only the first word of each instruction is shown. Do not use code marked "-."

The codes for the second word of a two-word instruction are described below.

	The second word		
BL	10	paaa	aaaa
BML	10	paaa	aaaa
BLA	10	pp00	pppp
BMLA	10	pp00	pppp
SEA	00	0111	nnnn
SZD	00	0010	1011

- \*, \*\*, and \*\*\* cannot be used in the M34513M2-XXXSP/FP.
- \* and \*\* cannot be used in the M34513M4-XXXSP/FP.
- \* and \*\* cannot be used in the M34513E4FP.
- \* cannot be used in the M34513M6-XXXFP.



**PRELIMINARY**  
 Notice: This is not a final specification.  
 Some parametric limits are subject to  
 change.

**INSTRUCTION CODE TABLE (continued) (for 4513 Group)**

D3-D0	Hex. notation	D9-D4	100000	100001	100010	100011	100100	100101	100110	100111	101000	101001	101010	101011	101100	101101	101110	101111	110000	110001	110010	110011	110100	110101	110110	110111	111000	111001	111010	111011	111100	111101	111110	111111	30-3F
		20	21	22	23	24	25	26	27	28	29	2A	2B	2C	2D	2E	2F																		
0000	0	-	TW3A	OP0A	T1AB	-	TAW6	IAP0	TAB1	SNZT1	-	WRST	TMA0	TAM0	XAM0	XAMI0	XAMD0	LXY																	
0001	1	-	TW4A	OP1A	T2AB	-	-	IAP1	TAB2	SNZT2	-	-	TMA1	TAM1	XAM1	XAMI1	XAMD1	LXY																	
0010	2	TJ1A	-	-	T3AB	TAJ1	TAMR	IAP2	TAB3	SNZT3	-	-	TMA2	TAM2	XAM2	XAMI2	XAMD2	LXY																	
0011	3	-	TW6A	OP3A	T4AB	-	TAI1	IAP3	TAB4	SNZT4	-	-	TMA3	TAM3	XAM3	XAMI3	XAMD3	LXY																	
0100	4	TQ1A	-	-	-	TAQ1	TAI2	-	-	-	-	-	TMA4	TAM4	XAM4	XAMI4	XAMD4	LXY																	
0101	5	TQ2A	-	-	-	TAQ2	-	-	-	-	-	-	TMA5	TAM5	XAM5	XAMI5	XAMD5	LXY																	
0110	6	TQ3A	TMRA	-	-	TAQ3	TAK0	-	-	-	-	-	TMA6	TAM6	XAM6	XAMI6	XAMD6	LXY																	
0111	7	-	TI1A	-	-	-	TAPU0	-	-	SNZAD	-	-	TMA7	TAM7	XAM7	XAMI7	XAMD7	LXY																	
1000	8	-	TI2A	-	TSIAB	-	-	-	TABSI	SNZSI	-	-	TMA8	TAM8	XAM8	XAMI8	XAMD8	LXY																	
1001	9	-	-	-	TADAB	TALA	-	-	TABAD	-	-	-	TMA9	TAM9	XAM9	XAMI9	XAMD9	LXY																	
1010	A	-	-	-	-	-	-	-	-	-	-	-	TMA10	TAM10	XAM10	XAMI10	XAMD10	LXY																	
1011	B	-	TK0A	-	TR3AB	TAW1	-	-	-	-	-	-	TMA11	TAM11	XAM11	XAMI11	XAMD11	LXY																	
1100	C	-	-	-	-	TAW2	-	-	-	-	-	-	TMA12	TAM12	XAM12	XAMI12	XAMD12	LXY																	
1101	D	-	-	TPU0A	-	TAW3	-	-	-	-	-	-	TMA13	TAM13	XAM13	XAMI13	XAMD13	LXY																	
1110	E	TW1A	-	-	-	TAW4	-	-	-	-	SST	-	TMA14	TAM14	XAM14	XAMI14	XAMD14	LXY																	
1111	F	TW2A	-	-	TR1AB	-	-	-	-	-	ADST	-	TMA15	TAM15	XAM15	XAMI15	XAMD15	LXY																	

The above table shows the relationship between machine language codes and machine language instructions. D3-D0 show the low-order 4 bits of the machine language code, and D9-D4 show the high-order 6 bits of the machine language code. The hexadecimal representation of the code is also provided. There are one-word instructions and two-word instructions, but only the first word of each instruction is shown. Do not use code marked "-."

The codes for the second word of a two-word instruction are described below.

	The second word		
BL	10	paaa	aaaa
BML	10	paaa	aaaa
BLA	10	pp00	pppp
BMLA	10	pp00	pppp
SEA	00	0111	nnnn
SZD	00	0010	1011

**PRELIMINARY**  
 Notice: This is not a final specification.  
 Some parametric limits are subject to change.

**INSTRUCTION CODE TABLE (for 4514 Group)**

D3-D0	Hex. notation	D9-D4																010000	011000
		00	01	02	03	04	05	06	07	08	09	0A	0B	0C	0D	0E	0F	010111	011111
0000	0	NOP	BLA	SZB 0	BMLA	-	TASP	A 0	LA 0	TABP 0	TABP 16	TABP 32	TABP 48*	BML	BML	BL	BL	BM	B
0001	1	-	CLD	SZB 1	-	-	TAD	A 1	LA 1	TABP 1	TABP 17	TABP 33	TABP 49*	BML	BML	BL	BL	BM	B
0010	2	POF	-	SZB 2	-	-	TAX	A 2	LA 2	TABP 2	TABP 18	TABP 34	TABP 50*	BML	BML	BL	BL	BM	B
0011	3	SNZP	INY	SZB 3	-	-	TAZ	A 3	LA 3	TABP 3	TABP 19	TABP 35	TABP 51*	BML	BML	BL	BL	BM	B
0100	4	DI	RD	SZD	-	RT	TAV1	A 4	LA 4	TABP 4	TABP 20	TABP 36	TABP 52*	BML	BML	BL	BL	BM	B
0101	5	EI	SD	SEAn	-	RTS	TAV2	A 5	LA 5	TABP 5	TABP 21	TABP 37	TABP 53*	BML	BML	BL	BL	BM	B
0110	6	RC	-	SEAM	-	RTI	-	A 6	LA 6	TABP 6	TABP 22	TABP 38	TABP 54*	BML	BML	BL	BL	BM	B
0111	7	SC	DEY	-	-	-	-	A 7	LA 7	TABP 7	TABP 23	TABP 39	TABP 55*	BML	BML	BL	BL	BM	B
1000	8	-	AND	-	SNZ0	LZ 0	-	A 8	LA 8	TABP 8	TABP 24	TABP 40	TABP 56*	BML	BML	BL	BL	BM	B
1001	9	-	OR	TDA	SNZ1	LZ 1	-	A 9	LA 9	TABP 9	TABP 25	TABP 41	TABP 57*	BML	BML	BL	BL	BM	B
1010	A	AM	TEAB	TABE	SNZI0	LZ 2	-	A 10	LA 10	TABP 10	TABP 26	TABP 42	TABP 58*	BML	BML	BL	BL	BM	B
1011	B	AMC	-	-	SNZI1	LZ 3	EPOF	A 11	LA 11	TABP 11	TABP 27	TABP 43	TABP 59*	BML	BML	BL	BL	BM	B
1100	C	TYA	CMA	-	-	RB 0	SB 0	A 12	LA 12	TABP 12	TABP 28	TABP 44	TABP 60*	BML	BML	BL	BL	BM	B
1101	D	-	RAR	-	-	RB 1	SB 1	A 13	LA 13	TABP 13	TABP 29	TABP 45	TABP 61*	BML	BML	BL	BL	BM	B
1110	E	TBA	TAB	-	TV2A	RB 2	SB 2	A 14	LA 14	TABP 14	TABP 30	TABP 46	TABP 62*	BML	BML	BL	BL	BM	B
1111	F	-	TAY	SZC	TV1A	RB 3	SB 3	A 15	LA 15	TABP 15	TABP 31	TABP 47	TABP 63*	BML	BML	BL	BL	BM	B

The above table shows the relationship between machine language codes and machine language instructions. D3-D0 show the low-order 4 bits of the machine language code, and D9-D4 show the high-order 6 bits of the machine language code. The hexadecimal representation of the code is also provided. There are one-word instructions and two-word instructions, but only the first word of each instruction is shown. Do not use code marked "-."

The codes for the second word of a two-word instruction are described below.

	The second word	
BL	10	paaa aaaa
BML	10	paaa aaaa
BLA	10	pp00 pppp
BMLA	10	pp00 pppp
SEA	00	0111 nnnn
SZD	00	0010 1011

\* \* cannot be used in the M34514M6-XXXXP.

**PRELIMINARY**  
 Notice: This is not a final specification.  
 Some parametric limits are subject to  
 change.

**INSTRUCTION CODE TABLE (continued) (for 4514 Group)**

D3-D0	D9-D4 Hex. notation	100000	100001	100010	100011	100100	100101	100110	100111	101000	101001	101010	101011	101100	101101	101110	101111	110000 111111
		20	21	22	23	24	25	26	27	28	29	2A	2B	2C	2D	2E	2F	30-3F
0000	0	-	TW3A	OP0A	T1AB	-	TAW6	IAP0	TAB1	SNZT1	-	WRST	TMA0	TAM0	XAM0	XAMI0	XAMD0	LXY
0001	1	-	TW4A	OP1A	T2AB	-	-	IAP1	TAB2	SNZT2	-	-	TMA1	TAM1	XAM1	XAMI1	XAMD1	LXY
0010	2	TJ1A	-	-	T3AB	TAJ1	TAMR	IAP2	TAB3	SNZT3	-	-	TMA2	TAM2	XAM2	XAMI2	XAMD2	LXY
0011	3	-	TW6A	OP3A	T4AB	-	TAI1	IAP3	TAB4	SNZT4	-	-	TMA3	TAM3	XAM3	XAMI3	XAMD3	LXY
0100	4	TQ1A	-	OP4A	-	TAQ1	TAI2	IAP4	-	-	-	-	TMA4	TAM4	XAM4	XAMI4	XAMD4	LXY
0101	5	TQ2A	-	OP5A	-	TAQ2	-	IAP5	-	-	-	-	TMA5	TAM5	XAM5	XAMI5	XAMD5	LXY
0110	6	TQ3A	TMRA	-	-	TAQ3	TAK0	-	-	-	-	-	TMA6	TAM6	XAM6	XAMI6	XAMD6	LXY
0111	7	-	TI1A	-	-	-	TAPU0	-	-	SNZAD	-	-	TMA7	TAM7	XAM7	XAMI7	XAMD7	LXY
1000	8	-	TI2A	TFR0A	TSIAB	-	-	-	TABS1	SNZSI	-	-	TMA8	TAM8	XAM8	XAMI8	XAMD8	LXY
1001	9	-	-	-	TADAB	TALA	-	-	TABAD	-	-	-	TMA9	TAM9	XAM9	XAMI9	XAMD9	LXY
1010	A	-	-	-	-	-	-	-	-	-	-	-	TMA10	TAM10	XAM10	XAMI10	XAMD10	LXY
1011	B	-	TK0A	-	TR3AB	TAW1	-	-	-	-	-	-	TMA11	TAM11	XAM11	XAMI11	XAMD11	LXY
1100	C	-	-	-	-	TAW2	-	-	-	-	-	-	TMA12	TAM12	XAM12	XAMI12	XAMD12	LXY
1101	D	-	-	TPU0A	-	TAW3	-	-	-	-	-	-	TMA13	TAM13	XAM13	XAMI13	XAMD13	LXY
1110	E	TW1A	-	-	-	TAW4	-	-	-	-	SST	-	TMA14	TAM14	XAM14	XAMI14	XAMD14	LXY
1111	F	TW2A	-	-	TR1AB	-	-	-	-	-	ADST	-	TMA15	TAM15	XAM15	XAMI15	XAMD15	LXY

The above table shows the relationship between machine language codes and machine language instructions. D3-D0 show the low-order 4 bits of the machine language code, and D9-D4 show the high-order 6 bits of the machine language code. The hexadecimal representation of the code is also provided. There are one-word instructions and two-word instructions, but only the first word of each instruction is shown. Do not use code marked "-."

The codes for the second word of a two-word instruction are described below.

	The second word
BL	10 paaa aaaa
BML	10 paaa aaaa
BLA	10 pp00 pppp
BMLA	10 pp00 pppp
SEA	00 0111 nnnn
SZD	00 0010 1011

**PRELIMINARY**  
 Notice: This is not a final specification.  
 Some parametric limits are subject to change.

**MACHINE INSTRUCTIONS**

Parameter Type of instructions	Mnemonic	Instruction code											Number of words	Number of cycles	Function
		D9	D8	D7	D6	D5	D4	D3	D2	D1	D0	Hexadecimal notation			
Register to register transfer	TAB	0	0	0	0	0	1	1	1	1	0	0 1 E	1	1	(A) ← (B)
	TBA	0	0	0	0	0	0	1	1	1	0	0 0 E	1	1	(B) ← (A)
	TAY	0	0	0	0	0	1	1	1	1	1	0 1 F	1	1	(A) ← (Y)
	TYA	0	0	0	0	0	0	1	1	0	0	0 0 C	1	1	(Y) ← (A)
	TEAB	0	0	0	0	0	1	1	0	1	0	0 1 A	1	1	(E7-E4) ← (B) (E3-E0) ← (A)
	TABE	0	0	0	0	1	0	1	0	1	0	0 2 A	1	1	(B) ← (E7-E4) (A) ← (E3-E0)
	TDA	0	0	0	0	1	0	1	0	0	1	0 2 9	1	1	(DR2-DR0) ← (A2-A0)
	TAD	0	0	0	1	0	1	0	0	0	1	0 5 1	1	1	(A2-A0) ← (DR2-DR0) (A3) ← 0
	TAZ	0	0	0	1	0	1	0	0	1	1	0 5 3	1	1	(A1, A0) ← (Z1, Z0) (A3, A2) ← 0
	TAX	0	0	0	1	0	1	0	0	1	0	0 5 2	1	1	(A) ← (X)
	TASP	0	0	0	1	0	1	0	0	0	0	0 5 0	1	1	(A2-A0) ← (SP2-SP0) (A3) ← 0
RAM addresses	LXY x, y	1	1	x3	x2	x1	x0	y3	y2	y1	y0	3 x y	1	1	(X) ← x, x = 0 to 15 (Y) ← y, y = 0 to 15
	LZ z	0	0	0	1	0	0	1	0	z1	z0	0 4 8 +z	1	1	(Z) ← z, z = 0 to 3
	INY	0	0	0	0	0	1	0	0	1	1	0 1 3	1	1	(Y) ← (Y) + 1
	DEY	0	0	0	0	0	1	0	1	1	1	0 1 7	1	1	(Y) ← (Y) - 1
RAM to register transfer	TAM j	1	0	1	1	0	0	j	j	j	j	2 C j	1	1	(A) ← (M(DP)) (X) ← (X)EXOR(j) j = 0 to 15
	XAM j	1	0	1	1	0	1	j	j	j	j	2 D j	1	1	(A) ← → (M(DP)) (X) ← (X)EXOR(j) j = 0 to 15
	XAMD j	1	0	1	1	1	1	j	j	j	j	2 F j	1	1	(A) ← → (M(DP)) (X) ← (X)EXOR(j) j = 0 to 15 (Y) ← (Y) - 1
	XAMI j	1	0	1	1	1	0	j	j	j	j	2 E j	1	1	(A) ← → (M(DP)) (X) ← (X)EXOR(j) j = 0 to 15 (Y) ← (Y) + 1
	TMA j	1	0	1	0	1	1	j	j	j	j	2 B j	1	1	(M(DP)) ← (A) (X) ← (X)EXOR(j) j = 0 to 15

**PRELIMINARY**  
 Notice: This is not a final specification.  
 Some parametric limits are subject to  
 change.

Skip condition	Carry flag CY	Detailed description
-	-	Transfers the contents of register B to register A.
-	-	Transfers the contents of register A to register B.
-	-	Transfers the contents of register Y to register A.
-	-	Transfers the contents of register A to register Y.
-	-	Transfers the contents of registers A and B to register E.
-	-	Transfers the contents of register E to registers A and B.
-	-	Transfers the contents of register A to register D.
-	-	Transfers the contents of register D to register A.
-	-	Transfers the contents of register Z to register A.
-	-	Transfers the contents of register X to register A.
-	-	Transfers the contents of stack pointer (SP) to register A.
Continuous description	-	Loads the value x in the immediate field to register X, and the value y in the immediate field to register Y. When the LXY instructions are continuously coded and executed, only the first LXY instruction is executed and other LXY instructions coded continuously are skipped.
-	-	Loads the value z in the immediate field to register Z.
(Y) = 0	-	Adds 1 to the contents of register Y. As a result of addition, when the contents of register Y is 0, the next instruction is skipped.
(Y) = 15	-	Subtracts 1 from the contents of register Y. As a result of subtraction, when the contents of register Y is 15, the next instruction is skipped.
-	-	After transferring the contents of M(DP) to register A, an exclusive OR operation is performed between register X and the value j in the immediate field, and stores the result in register X.
-	-	After exchanging the contents of M(DP) with the contents of register A, an exclusive OR operation is performed between register X and the value j in the immediate field, and stores the result in register X.
(Y) = 15	-	After exchanging the contents of M(DP) with the contents of register A, an exclusive OR operation is performed between register X and the value j in the immediate field, and stores the result in register X. Subtracts 1 from the contents of register Y. As a result of subtraction, when the contents of register Y is 15, the next instruction is skipped.
(Y) = 0	-	After exchanging the contents of M(DP) with the contents of register A, an exclusive OR operation is performed between register X and the value j in the immediate field, and stores the result in register X. Adds 1 to the contents of register Y. As a result of addition, when the contents of register Y is 0, the next instruction is skipped.
-	-	After transferring the contents of register A to M(DP), an exclusive OR operation is performed between register X and the value j in the immediate field, and stores the result in register X.

**MACHINE INSTRUCTIONS (continued)**

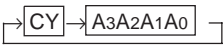
Parameter Type of instructions	Mnemonic	Instruction code										Hexadecimal notation	Number of words	Number of cycles	Function
		D9	D8	D7	D6	D5	D4	D3	D2	D1	D0				
Arithmetic operation	LA n	0	0	0	1	1	1	n	n	n	n	0 7 n	1	1	(A) ← n n = 0 to 15
	TABP p	0	0	1	0	p5	p4	p3	p2	p1	p0	0 8 p +p	1	3	(SP) ← (SP) + 1 (SK(SP)) ← (PC) (PCH) ← p (PCL) ← (DR2-DR0, A3-A0) (B) ← (ROM(PC)) <sup>7-4</sup> (A) ← (ROM(PC)) <sup>3-0</sup> (PC) ← (SK(SP)) (SP) ← (SP) - 1 (Note)
	AM	0	0	0	0	0	0	1	0	1	0	0 0 A	1	1	(A) ← (A) + (M(DP))
	AMC	0	0	0	0	0	0	1	0	1	1	0 0 B	1	1	(A) ← (A) + (M(DP)) + (CY) (CY) ← Carry
	A n	0	0	0	1	1	0	n	n	n	n	0 6 n	1	1	(A) ← (A) + n n = 0 to 15
	AND	0	0	0	0	0	1	1	0	0	0	0 1 8	1	1	(A) ← (A) AND (M(DP))
	OR	0	0	0	0	0	1	1	0	0	1	0 1 9	1	1	(A) ← (A) OR (M(DP))
	SC	0	0	0	0	0	0	0	1	1	1	0 0 7	1	1	(CY) ← 1
	RC	0	0	0	0	0	0	0	1	1	0	0 0 6	1	1	(CY) ← 0
	SZC	0	0	0	0	1	0	1	1	1	1	0 2 F	1	1	(CY) = 0 ?
	CMA	0	0	0	0	0	1	1	1	0	0	0 1 C	1	1	(A) ← (A) <sup>¯</sup>
	RAR	0	0	0	0	0	1	1	1	0	1	0 1 D	1	1	
Bit operation	SB j	0	0	0	1	0	1	1	1	j	j	0 5 C +j	1	1	(Mj(DP)) ← 1 j = 0 to 3
	RB j	0	0	0	1	0	0	1	1	j	j	0 4 C +j	1	1	(Mj(DP)) ← 0 j = 0 to 3
	SZB j	0	0	0	0	1	0	0	0	j	j	0 2 j	1	1	(Mj(DP)) = 0 ? j = 0 to 3
Comparison operation	SEAM	0	0	0	0	1	0	0	1	1	0	0 2 6	1	1	(A) = (M(DP)) ?
	SEA n	0	0	0	0	1	0	0	1	0	1	0 2 5	2	2	(A) = n ? n = 0 to 15
		0	0	0	1	1	1	n	n	n	n	0 7 n			

Note : p is 0 to 15 for M34513M2, p is 0 to 31 for M34513M4/E4, p is 0 to 47 for M34513M6 and M34514M6, and p is 0 to 63 for M34513M8/E8 and M34514M8/E8.

**PRELIMINARY**  
 Notice: This is not a final specification.  
 Some parametric limits are subject to  
 change.

Skip condition	Carry flag CY	Detailed description
Continuous description - - - Overflow = 0 - - - - (CY) = 0 - -	- - 0/1 - - 1 0 - - 0/1	Loads the value n in the immediate field to register A. When the LA instructions are continuously coded and executed, only the first LA instruction is executed and other LA instructions coded continuously are skipped. Transfers bits 7 to 4 to register B and bits 3 to 0 to register A. These bits 7 to 0 are the ROM pattern in address (DR <sub>2</sub> DR <sub>1</sub> DR <sub>0</sub> A <sub>3</sub> A <sub>2</sub> A <sub>1</sub> A <sub>0</sub> ) <sub>2</sub> specified by registers A and D in page p. When this instruction is executed, 1 stage of stack register is used. Adds the contents of M(DP) to register A. Stores the result in register A. The contents of carry flag CY remains unchanged. Adds the contents of M(DP) and carry flag CY to register A. Stores the result in register A and carry flag CY. Adds the value n in the immediate field to register A. The contents of carry flag CY remains unchanged. Skips the next instruction when there is no overflow as the result of operation. Takes the AND operation between the contents of register A and the contents of M(DP), and stores the result in register A. Takes the OR operation between the contents of register A and the contents of M(DP), and stores the result in register A. Sets (1) to carry flag CY. Clears (0) to carry flag CY. Skips the next instruction when the contents of carry flag CY is "0." Stores the one's complement for register A's contents in register A. Rotates 1 bit of the contents of register A including the contents of carry flag CY to the right.
- - (M <sub>j</sub> (DP)) = 0 j = 0 to 3	- - -	Sets (1) the contents of bit j (bit specified by the value j in the immediate field) of M(DP). Clears (0) the contents of bit j (bit specified by the value j in the immediate field) of M(DP). Skips the next instruction when the contents of bit j (bit specified by the value j in the immediate field) of M(DP) is "0."
(A) = (M(DP)) (A) = n	- -	Skips the next instruction when the contents of register A is equal to the contents of M(DP). Skips the next instruction when the contents of register A is equal to the value n in the immediate field.

**PRELIMINARY**  
 Notice: This is not a final specification.  
 Some parametric limits are subject to  
 change.

**MACHINE INSTRUCTIONS (continued)**

Parameter Type of instructions	Mnemonic	Instruction code										Hexadecimal notation	Number of words	Number of cycles	Function
		D9	D8	D7	D6	D5	D4	D3	D2	D1	D0				
Branch operation	B a	0	1	1	a6	a5	a4	a3	a2	a1	a0	1 8 a +a	1	1	(PCL) ← a6-a0
	BL p, a	0	0	1	1	1	p4	p3	p2	p1	p0	0 E p +p	2	2	(PCH) ← p (PCL) ← a6-a0 (Note)
		1	0	p5	a6	a5	a4	a3	a2	a1	a0	2 p a +a			
	BLA p	0	0	0	0	0	1	0	0	0	0	0 1 0	2	2	(PCH) ← p (PCL) ← (DR2-DR0, A3-A0) (Note)
1		0	p5	p4	0	0	p3	p2	p1	p0	2 p p				
Subroutine operation	BM a	0	1	0	a6	a5	a4	a3	a2	a1	a0	1 a a	1	1	(SP) ← (SP) + 1 (SK(SP)) ← (PC) (PCH) ← 2 (PCL) ← a6-a0
	BML p, a	0	0	1	1	0	p4	p3	p2	p1	p0	0 C p +p	2	2	(SP) ← (SP) + 1 (SK(SP)) ← (PC) (PCH) ← p (PCL) ← a6-a0 (Note)
		1	0	p5	a6	a5	a4	a3	a2	a1	a0	2 p a +a			
	BMLA p	0	0	0	0	1	1	0	0	0	0	0 3 0	2	2	(SP) ← (SP) + 1 (SK(SP)) ← (PC) (PCH) ← p (PCL) ← (DR2-DR0, A3-A0) (Note)
1		0	p5	p4	0	0	p3	p2	p1	p0	2 p p				
Return operation	RTI	0	0	0	1	0	0	0	1	1	0	0 4 6	1	1	(PC) ← (SK(SP)) (SP) ← (SP) - 1
	RT	0	0	0	1	0	0	0	1	0	0	0 4 4	1	2	(PC) ← (SK(SP)) (SP) ← (SP) - 1
	RTS	0	0	0	1	0	0	0	1	0	1	0 4 5	1	2	(PC) ← (SK(SP)) (SP) ← (SP) - 1
Interrupt operation	DI	0	0	0	0	0	0	0	1	0	0	0 0 4	1	1	(INTE) ← 0
	EI	0	0	0	0	0	0	0	1	0	1	0 0 5	1	1	(INTE) ← 1
	SNZ0	0	0	0	0	1	1	1	0	0	0	0 3 8	1	1	(EXF0) = 1 ? After skipping (EXF0) ← 0
	SNZ1	0	0	0	0	1	1	1	0	0	1	0 3 9	1	1	(EXF1) = 1 ? After skipping (EXF1) ← 0

Note : p is 0 to 15 for M34513M2, p is 0 to 31 for M34513M4/E4, p is 0 to 47 for M34513M6 and M34514M6, and p is 0 to 63 for M34513M8/E8 and M34514M8/E8.



**PRELIMINARY**  
 Notice: This is not a final specification.  
 Some parametric limits are subject to  
 change.

Skip condition	Carry flag CY	Detailed description
-	-	Branch within a page : Branches to address a in the identical page.
-	-	Branch out of a page : Branches to address a in page p.
-	-	Branch out of a page : Branches to address (DR2 DR1 DR0 A3 A2 A1 A0) <sub>2</sub> specified by registers D and A in page p.
-	-	Call the subroutine in page 2 : Calls the subroutine at address a in page 2.
-	-	Call the subroutine : Calls the subroutine at address a in page p.
-	-	Call the subroutine : Calls the subroutine at address (DR2 DR1 DR0 A3 A2 A1 A0) <sub>2</sub> specified by registers D and A in page p.
-	-	Returns from interrupt service routine to main routine. Returns each value of data pointer (X, Y, Z), carry flag, skip status, NOP mode status by the continuous description of the LA/LXY instruction, register A and register B to the states just before interrupt.
-	-	Returns from subroutine to the routine called the subroutine.
Skip at uncondition	-	Returns from subroutine to the routine called the subroutine, and skips the next instruction at uncondition.
-	-	Clears (0) to the interrupt enable flag INTE, and disables the interrupt.
-	-	Sets (1) to the interrupt enable flag INTE, and enables the interrupt.
(EXF0) = 1	-	Skips the next instruction when the contents of EXF0 flag is "1." After skipping, clears (0) to the EXF0 flag.
(EXF1) = 1	-	Skips the next instruction when the contents of EXF1 flag is "1." After skipping, clears (0) to the EXF1 flag.

**PRELIMINARY**  
 Notice: This is not a final specification.  
 Some parametric limits are subject to  
 change.

**MACHINE INSTRUCTIONS (continued)**

Parameter Type of instructions	Mnemonic	Instruction code										Hexadecimal notation	Number of words	Number of cycles	Function
		D9	D8	D7	D6	D5	D4	D3	D2	D1	D0				
Interrupt operation	SNZI0	0	0	0	0	1	1	1	0	1	0	0 3 A	1	1	I12 = 1 : (INT0) = "H" ?  I12 = 0 : (INT0) = "L" ?
	SNZI1	0	0	0	0	1	1	1	0	1	1	0 3 B	1	1	I22 = 1 : (INT1) = "H" ?  I22 = 0 : (INT1) = "L" ?
	TAV1	0	0	0	1	0	1	0	1	0	0	0 5 4	1	1	(A) ← (V1)
	TV1A	0	0	0	0	1	1	1	1	1	1	0 3 F	1	1	(V1) ← (A)
	TAV2	0	0	0	1	0	1	0	1	0	1	0 5 5	1	1	(A) ← (V2)
	TV2A	0	0	0	0	1	1	1	1	1	0	0 3 E	1	1	(V2) ← (A)
	TAI1	1	0	0	1	0	1	0	0	1	1	2 5 3	1	1	(A) ← (I1)
	TI1A	1	0	0	0	0	1	0	1	1	1	2 1 7	1	1	(I1) ← (A)
	TAI2	1	0	0	1	0	1	0	1	0	0	2 5 4	1	1	(A) ← (I2)
TI2A	1	0	0	0	0	1	1	0	0	0	2 1 8	1	1	(I2) ← (A)	
Timer operation	TAW1	1	0	0	1	0	0	1	0	1	1	2 4 B	1	1	(A) ← (W1)
	TW1A	1	0	0	0	0	0	1	1	1	0	2 0 E	1	1	(W1) ← (A)
	TAW2	1	0	0	1	0	0	1	1	0	0	2 4 C	1	1	(A) ← (W2)
	TW2A	1	0	0	0	0	0	1	1	1	1	2 0 F	1	1	(W2) ← (A)
	TAW3	1	0	0	1	0	0	1	1	0	1	2 4 D	1	1	(A) ← (W3)
	TW3A	1	0	0	0	0	1	0	0	0	0	2 1 0	1	1	(W3) ← (A)
	TAW4	1	0	0	1	0	0	1	1	1	0	2 4 E	1	1	(A) ← (W4)
	TW4A	1	0	0	0	0	1	0	0	0	1	2 1 1	1	1	(W4) ← (A)
	TAW6	1	0	0	1	0	1	0	0	0	0	2 5 0	1	1	(A) ← (W6)
TW6A	1	0	0	0	0	1	0	0	1	1	2 1 3	1	1	(W6) ← (A)	



**PRELIMINARY**  
 Notice: This is not a final specification.  
 Some parametric limits are subject to  
 change.

**MACHINE INSTRUCTIONS (continued)**

Parameter Type of instructions	Mnemonic	Instruction code										Hexadecimal notation	Number of words	Number of cycles	Function
		D9	D8	D7	D6	D5	D4	D3	D2	D1	D0				
Timer operation	TAB1	1	0	0	1	1	1	0	0	0	0	2 7 0	1	1	(B) ← (T17-T14) (A) ← (T13-T10)
	T1AB	1	0	0	0	1	1	0	0	0	0	2 3 0	1	1	(R17-R14) ← (B) (T17-T14) ← (B) (R13-R10) ← (A) (T13-T10) ← (A)
	TAB2	1	0	0	1	1	1	0	0	0	1	2 7 1	1	1	(B) ← (T27-T24) (A) ← (T23-T20)
	T2AB	1	0	0	0	1	1	0	0	0	1	2 3 1	1	1	(R27-R24) ← (B) (T27-T24) ← (B) (R23-R20) ← (A) (T23-T20) ← (A)
	TAB3	1	0	0	1	1	1	0	0	1	0	2 7 2	1	1	(B) ← (T37-T34) (A) ← (T33-T30)
	T3AB	1	0	0	0	1	1	0	0	1	0	2 3 2	1	1	(R37-R34) ← (B) (T37-T34) ← (B) (R33-R30) ← (A) (T33-T30) ← (A)
	TAB4	1	0	0	1	1	1	0	0	1	1	2 7 3	1	1	(B) ← (T47-T44) (A) ← (T43-T40)
	T4AB	1	0	0	0	1	1	0	0	1	1	2 3 3	1	1	(R47-R44) ← (B) (T47-T44) ← (B) (R43-R40) ← (A) (T43-T40) ← (A)
	TR1AB	1	0	0	0	1	1	1	1	1	1	2 3 F	1	1	(R17-R14) ← (B) (R13-R10) ← (A)
	TR3AB	1	0	0	0	1	1	1	0	1	1	2 3 B	1	1	(R37-R34) ← (B) (R33-R30) ← (A)
	SNZT1	1	0	1	0	0	0	0	0	0	0	2 8 0	1	1	(T1F) = 1 ? After skipping (T1F) ← 0
	SNZT2	1	0	1	0	0	0	0	0	0	1	2 8 1	1	1	(T2F) = 1 ? After skipping (T2F) ← 0
	SNZT3	1	0	1	0	0	0	0	0	1	0	2 8 2	1	1	(T3F) = 1 ? After skipping (T3F) ← 0
	SNZT4	1	0	1	0	0	0	0	0	1	1	2 8 3	1	1	(T4F) = 1 ? After skipping (T4F) ← 0

**PRELIMINARY**  
 Notice: This is not a final specification.  
 Some parametric limits are subject to  
 change.

Skip condition	Carry flag CY	Detailed description
-	-	Transfers the contents of timer 1 to registers A and B.
-	-	Transfers the contents of registers A and B to timer 1 and timer 1 reload register.
-	-	Transfers the contents of timer 2 to registers A and B.
-	-	Transfers the contents of registers A and B to timer 2 and timer 2 reload register.
-	-	Transfers the contents of timer 3 to registers A and B.
-	-	Transfers the contents of registers A and B to timer 3 and timer 3 reload register.
-	-	Transfers the contents of timer 4 to registers A and B.
-	-	Transfers the contents of registers A and B to timer 4 and timer 4 reload register.
-	-	Transfers the contents of registers A and B to timer 1 reload register.
-	-	Transfers the contents of registers A and B to timer 3 reload register.
(T1F) = 1	-	Skips the next instruction when the contents of T1F flag is "1." After skipping, clears (0) to T1F flag.
(T2F) = 1	-	Skips the next instruction when the contents of T2F flag is "1." After skipping, clears (0) to T2F flag.
(T3F) = 1	-	Skips the next instruction when the contents of T3F flag is "1." After skipping, clears (0) to T3F flag.
(T4F) = 1	-	Skips the next instruction when the contents of T4F flag is "1." After skipping, clears (0) to T4F flag.

**PRELIMINARY**  
 Notice: This is not a final specification.  
 Some parametric limits are subject to  
 change.

**MACHINE INSTRUCTIONS (continued)**

Parameter Type of instructions	Mnemonic	Instruction code											Number of words	Number of cycles	Function
		D9	D8	D7	D6	D5	D4	D3	D2	D1	D0	Hexadecimal notation			
Input/Output operation	IAP0	1	0	0	1	1	0	0	0	0	0	2 6 0	1	1	(A) ← (P0)
	OP0A	1	0	0	0	1	0	0	0	0	0	2 2 0	1	1	(P0) ← (A)
	IAP1	1	0	0	1	1	0	0	0	0	1	2 6 1	1	1	(A) ← (P1)
	OP1A	1	0	0	0	1	0	0	0	0	1	2 2 1	1	1	(P1) ← (A)
	IAP2	1	0	0	1	1	0	0	0	1	0	2 6 2	1	1	(A <sub>2</sub> -A <sub>0</sub> ) ← (P <sub>22</sub> -P <sub>20</sub> ) (A <sub>3</sub> ) ← 0
	IAP3	1	0	0	1	1	0	0	0	1	1	2 6 3	1	1	(A) ← (P3)
	OP3A	1	0	0	0	1	0	0	0	1	1	2 2 3	1	1	(P3) ← (A)
	IAP4*	1	0	0	1	1	0	0	1	0	0	2 6 4	1	1	(A) ← (P4)
	OP4A*	1	0	0	0	1	0	0	1	0	0	2 2 4	1	1	(P4) ← (A)
	IAP5*	1	0	0	1	1	0	0	1	0	1	2 6 5	1	1	(A) ← (P5)
	OP5A*	1	0	0	0	1	0	0	1	0	1	2 2 5	1	1	(P5) ← (A)
	CLD	0	0	0	0	0	1	0	0	0	1	0 1 1	1	1	(D) ← 1
	RD	0	0	0	0	0	1	0	1	0	0	0 1 4	1	1	(D(Y)) ← 0 (Y) = 0 to 7
	SD	0	0	0	0	0	1	0	1	0	1	0 1 5	1	1	(D(Y)) ← 1 (Y) = 0 to 7
	SZD	0	0	0	0	1	0	0	1	0	0	0 2 4	2	2	(D(Y)) = 0 ? (Y) = 0 to 7
		0	0	0	0	1	0	1	0	1	1	0 2 B			
	TK0A	1	0	0	0	0	1	1	0	1	1	2 1 B	1	1	(K0) ← (A)
	TAK0	1	0	0	1	0	1	0	1	1	0	2 5 6	1	1	(A) ← (K0)
TPU0A	1	0	0	0	1	0	1	1	0	1	2 2 D	1	1	(PU0) ← (A)	
TAPU0	1	0	0	1	0	1	0	1	1	1	2 5 7	1	1	(A) ← (PU0)	
TFR0A*	1	0	0	0	1	0	1	0	0	0	2 2 8	1	1	(FR0) ← (A)	

\*: The 4513 Group does not have these instructions.

**PRELIMINARY**  
 Notice: This is not a final specification.  
 Some parametric limits are subject to  
 change.

Skip condition	Carry flag CY	Detailed description
-	-	Transfers the input of port P0 to register A.
-	-	Outputs the contents of register A to port P0.
-	-	Transfers the input of port P1 to register A.
-	-	Outputs the contents of register A to port P1.
-	-	Transfers the input of port P2 to register A.
-	-	Transfers the input of port P3 to register A.
-	-	Outputs the contents of register A to port P3.
-	-	Transfers the input of port P4 to register A.
-	-	Outputs the contents of register A to port P4.
-	-	Transfers the input of port P5 to register A.
-	-	Outputs the contents of register A to port P5.
-	-	Sets (1) to port D.
-	-	Clears (0) to a bit of port D specified by register Y.
(D(Y)) = 0 (Y) = 0 to 7	-	Skips the next instruction when a bit of port D specified by register Y is "0."
-	-	Transfers the contents of register A to key-on wakeup control register K0.
-	-	Transfers the contents of key-on wakeup control register K0 to register A.
-	-	Transfers the contents of register A to pull-up control register PU0.
-	-	Transfers the contents of pull-up control register PU0 to register A.
-	-	Transfers the contents of register A to direction register FR0.

**PRELIMINARY**  
 Notice: This is not a final specification.  
 Some parametric limits are subject to  
 change.

**MACHINE INSTRUCTIONS (continued)**

Parameter Type of instructions	Mnemonic	Instruction code										Hexadecimal notation	Number of words	Number of cycles	Function
		D9	D8	D7	D6	D5	D4	D3	D2	D1	D0				
Serial I/O control operation	TABSI	1	0	0	1	1	1	1	0	0	0	2 7 8	1	1	(A) ← (SI3-SI0) (B) ← (SI7-SI4)
	TSIAB	1	0	0	0	1	1	1	0	0	0	2 3 8	1	1	(SI3-SI0) ← (A) (SI7-SI4) ← (B)
	TAJ1	1	0	0	1	0	0	0	0	1	0	2 4 2	1	1	(A) ← (J1)
	TJ1A	1	0	0	0	0	0	0	0	1	0	2 0 2	1	1	(J1) ← (A)
	SST	1	0	1	0	0	1	1	1	1	0	2 9 E	1	1	(SIOF) ← 0 Serial I/O starting
	SNZSI	1	0	1	0	0	0	1	0	0	0	2 8 8	1	1	(SIOF) = 1 ? After skipping (SIOF) ← 0
A-D conversion operation	TABAD	1	0	0	1	1	1	1	0	0	1	2 7 9	1	1	(A) ← (AD5-AD2) (B) ← (AD9-AD6) However, in the comparator mode, (A) ← (AD3-AD0) (B) ← (AD7-AD4)
	TALA	1	0	0	1	0	0	1	0	0	1	2 4 9	1	1	(A) ← (AD1, AD0, 0, 0)
	TADAB	1	0	0	0	1	1	1	0	0	1	2 3 9	1	1	(AD3-AD0) ← (A) (AD7-AD4) ← (B)
	TAQ1	1	0	0	1	0	0	0	1	0	0	2 4 4	1	1	(A) ← (Q1)
	TQ1A	1	0	0	0	0	0	0	1	0	0	2 0 4	1	1	(Q1) ← (A)
	ADST	1	0	1	0	0	1	1	1	1	1	2 9 F	1	1	(ADF) ← 0 A-D conversion starting
	SNZAD	1	0	1	0	0	0	0	1	1	1	2 8 7	1	1	(ADF) = 1 ? After skipping (ADF) ← 0
	TAQ2	1	0	0	1	0	0	0	1	0	1	2 4 5	1	1	(A) ← (Q2)
	TQ2A	1	0	0	0	0	0	0	1	0	1	2 0 5	1	1	(Q2) ← (A)
Other operation	NOP	0	0	0	0	0	0	0	0	0	0	0 0 0	1	1	(PC) ← (PC) + 1
	POF	0	0	0	0	0	0	0	0	1	0	0 0 2	1	1	RAM back-up
	EPOF	0	0	0	1	0	1	1	0	1	1	0 5 B	1	1	POF instruction valid
	SNZP	0	0	0	0	0	0	0	0	1	1	0 0 3	1	1	(P) = 1 ?
	WRST	1	0	1	0	1	0	0	0	0	0	2 A 0	1	1	(WDF1) ← 0 (WEF) ← 1
	TAMR	1	0	0	1	0	1	0	0	1	0	2 5 2	1	1	(A) ← (MR)
	TMRA	1	0	0	0	0	1	0	1	1	0	2 1 6	1	1	(MR) ← (A)
	TAQ3	1	0	0	1	0	0	0	1	1	0	2 4 6	1	1	(A) ← (Q3)
	TQ3A	1	0	0	0	0	0	0	1	1	0	2 0 6	1	1	(Q33, Q32) ← (A3, A2) (Q31) ← (CMP1 comparison result) (Q30) ← (CMP0 comparison result)



**PRELIMINARY**  
 Notice: This is not a final specification.  
 Some parametric limits are subject to  
 change.

Skip condition	Carry flag CY	Detailed description
–  –  –  –  –  (SIOF) = 1	–	Transfers the contents of serial I/O register SI to registers A and B.
	–	Transfers the contents of registers A and B to serial I/O register SI.
	–	Transfers the contents of serial I/O mode register J1 to register A.
	–	Transfers the contents of register A to serial I/O mode register J1.
	–	Clears (0) to SIOF flag and starts serial I/O.
	–	Skips the next instruction when the contents of SIOF flag is "1." After skipping, clears (0) to SIOF flag.
–  –  –  –  –  (ADF) = 1	–	Transfers the high-order 8 bits of the contents of register AD to registers A and B.
	–	Transfers the low-order 2 bits of the contents of register AD to the high-order 2 bits of the contents of register A. Simultaneously, the low-order 2 bits of the contents of the register A is "0."
	–	Transfers the contents of registers A and B to the comparator register at the comparator mode.
	–	Transfers the contents of the A-D control register Q1 to register A.
	–	Transfers the contents of register A to the A-D control register Q1.
	–	Clears the ADF flag, and the A-D conversion at the A-D conversion mode or the comparator operation at the comparator mode is started.
	–	Skips the next instruction when the contents of ADF flag is "1." After skipping, clears (0) the contents of ADF flag.
	–	Transfers the contents of the A-D control register Q2 to register A.
–  –  –  –  –  (P) = 1	–	No operation
	–	Puts the system in RAM back-up state by executing the POF instruction after executing the EPOF instruction.
	–	Makes the immediate POF instruction valid by executing the EPOF instruction.
	–	Skips the next instruction when P flag is "1". After skipping, P flag remains unchanged.
	–	Operates the watchdog timer and initializes the watchdog timer flag WDF1.
	–	Transfers the contents of the clock control register MR to register A.
	–	Transfers the contents of register A to the clock control register MR.
	–	Transfers the contents of the voltage comparator control register Q3 to register A.
	–	Transfers the contents of the high-order 2 bits of register A to the high-order 2 bits of voltage comparator control register Q3, and the comparison result of the voltage comparator is transferred to the low-order 2 bits of the register Q3.

**PRELIMINARY**  
 Notice: This is not a final specification.  
 Some parametric limits are subject to  
 change.

## CONTROL REGISTERS

Interrupt control register V1		at reset : 0000 <sub>2</sub>		at RAM back-up : 0000 <sub>2</sub>		R/W
V13	Timer 2 interrupt enable bit	0	Interrupt disabled (SNZT2 instruction is valid)			
		1	Interrupt enabled (SNZT2 instruction is invalid)			
V12	Timer 1 interrupt enable bit	0	Interrupt disabled (SNZT1 instruction is valid)			
		1	Interrupt enabled (SNZT1 instruction is invalid)			
V11	External 1 interrupt enable bit	0	Interrupt disabled (SNZ1 instruction is valid)			
		1	Interrupt enabled (SNZ1 instruction is invalid)			
V10	External 0 interrupt enable bit	0	Interrupt disabled (SNZ0 instruction is valid)			
		1	Interrupt enabled (SNZ0 instruction is invalid)			
Interrupt control register V2		at reset : 0000 <sub>2</sub>		at RAM back-up : 0000 <sub>2</sub>		R/W
V23	Serial I/O interrupt enable bit	0	Interrupt disabled (SNZSI instruction is valid)			
		1	Interrupt enabled (SNZSI instruction is invalid)			
V22	A-D interrupt enable bit	0	Interrupt disabled (SNZAD instruction is valid)			
		1	Interrupt enabled (SNZAD instruction is invalid)			
V21	Timer 4 interrupt enable bit	0	Interrupt disabled (SNZT4 instruction is valid)			
		1	Interrupt enabled (SNZT4 instruction is invalid)			
V20	Timer 3 interrupt enable bit	0	Interrupt disabled (SNZT3 instruction is valid)			
		1	Interrupt enabled (SNZT3 instruction is invalid)			
Interrupt control register I1		at reset : 0000 <sub>2</sub>		at RAM back-up : state retained		R/W
I13	Not used	0	This bit has no function, but read/write is enabled.			
		1				
I12	Interrupt valid waveform for INT0 pin/ return level selection bit (Note 2)	0	Falling waveform ("L" level of INT0 pin is recognized with the SNZI0 instruction)/"L" level			
		1	Rising waveform ("H" level of INT0 pin is recognized with the SNZI0 instruction)/"H" level			
I11	INT0 pin edge detection circuit control bit	0	One-sided edge detected			
		1	Both edges detected			
I10	INT0 pin timer 1 control enable bit	0	Disabled			
		1	Enabled			
Interrupt control register I2		at reset : 0000 <sub>2</sub>		at RAM back-up : state retained		R/W
I23	Not used	0	This bit has no function, but read/write is enabled.			
		1				
I22	Interrupt valid waveform for INT1 pin/ return level selection bit (Note 3)	0	Falling waveform ("L" level of INT1 pin is recognized with the SNZI1 instruction)/"L" level			
		1	Rising waveform ("H" level of INT1 pin is recognized with the SNZI1 instruction)/"H" level			
I21	INT1 pin edge detection circuit control bit	0	One-sided edge detected			
		1	Both edges detected			
I20	INT1 pin timer 3 control enable bit	0	Disabled			
		1	Enabled			

Notes 1: "R" represents read enabled, and "W" represents write enabled.

2: When the contents of I12 is changed, the external interrupt request flag EXF0 may be set. Accordingly, clear EXF0 flag with the SNZ0 instruction.

3: When the contents of I22 is changed, the external interrupt request flag EXF1 may be set. Accordingly, clear EXF1 flag with the SNZ1 instruction.

**PRELIMINARY**  
 Notice: This is not a final specification.  
 Some parametric limits are subject to  
 change.

Timer control register W1		at reset : 00002		at RAM back-up : 00002		R/W
W13	Prescaler control bit	0	Stop (state initialized)			
		1	Operating			
W12	Prescaler dividing ratio selection bit	0	Instruction clock divided by 4			
		1	Instruction clock divided by 16			
W11	Timer 1 control bit	0	Stop (state retained)			
		1	Operating			
W10	Timer 1 count start synchronous circuit control bit	0	Count start synchronous circuit not selected			
		1	Count start synchronous circuit selected			
Timer control register W2		at reset : 00002		at RAM back-up : state retained		R/W
W23	Timer 2 control bit	0	Stop (state retained)			
		1	Operating			
W22	Not used	0	This bit has no function, but read/write is enabled.			
		1				
W21	Timer 2 count source selection bits	W21 W20		Count source		
		0	0	Timer 1 underflow signal		
W20	Timer 2 count source selection bits	0	1	Prescaler output		
		1	0	CNTR0 input		
		1	1	16 bit timer (WDT) underflow signal		
Timer control register W3		at reset : 00002		at RAM back-up : state retained		R/W
W33	Timer 3 control bit	0	Stop (state retained)			
		1	Operating			
W32	Timer 3 count start synchronous circuit control bit	0	Count start synchronous circuit not selected			
		1	Count start synchronous circuit selected			
W31	Timer 3 count source selection bits	W31 W30		Count source		
		0	0	Timer 2 underflow signal		
W30	Timer 3 count source selection bits	0	1	Prescaler output		
		1	0	Not available		
		1	1	Not available		
Timer control register W4		at reset : 00002		at RAM back-up : state retained		R/W
W43	Timer 4 control bit	0	Stop (state retained)			
		1	Operating			
W42	Not used	0	This bit has no function, but read/write is enabled.			
		1				
W41	Timer 4 count source selection bits	W41 W40		Count source		
		0	0	Timer 3 underflow signal		
W40	Timer 4 count source selection bits	0	1	Prescaler output		
		1	0	CNTR1 input		
		1	1	Not available		
Timer control register W6		at reset : 00002		at RAM back-up : state retained		R/W
W63	CNTR1 output control bit	0	Timer 3 underflow signal output divided by 2			
		1	CNTR1 output control by timer 4 underflow signal divided by 2			
W62	D7/CNTR1 function selection bit	0	D7(I/O)/CNTR1 input			
		1	CNTR1 (I/O)/D7(input)			
W61	CNTR0 output control bit	0	Timer 1 underflow signal output divided by 2			
		1	CNTR0 output control by timer 2 underflow signal divided by 2			
W60	D6/CNTR0 output control bit	0	D6(I/O)/CNTR0 input			
		1	CNTR0 (I/O)/D6(input)			

Note: "R" represents read enabled, and "W" represents write enabled.

**PRELIMINARY**  
 Notice: This is not a final specification.  
 Some parametric limits are subject to  
 change.

Serial I/O mode register J1		at reset : 00002		at RAM back-up : state retained	R/W
J13	Not used	0	This bit has no function, but read/write is enabled.		
		1			
J12	Serial I/O internal clock dividing ratio selection bit	0	Instruction clock signal divided by 8		
		1	Instruction clock signal divided by 4		
J11	Serial I/O port selection bit	0	Input ports P20, P21, P22 selected		
		1	Serial I/O ports SCK, SOUT, SIN/input ports P20, P21, P22 selected		
J10	Serial I/O synchronous clock selection bit	0	External clock		
		1	Internal clock (instruction clock divided by 4 or 8)		
A-D control register Q1		at reset : 00002		at RAM back-up : state retained	R/W
Q13	Note used	0	This bit has no function, but read/write is enabled.		
		1			
Q12	Analog input pin selection bits (Note 2)	Q12	Q11	Q10	Selected pins
		0	0	0	AIN0
0		0	1	AIN1	
Q11		0	1	0	AIN2
		0	1	1	AIN3
Q10		1	0	0	AIN4 (Not available for the 4513 Group)
		1	0	1	AIN5 (Not available for the 4513 Group)
		1	1	0	AIN6 (Not available for the 4513 Group)
	1	1	1	AIN7 (Not available for the 4513 Group)	
A-D control register Q2		at reset : 00002		at RAM back-up : state retained	R/W
Q23	A-D operation mode selection bit	0	A-D conversion mode		
		1	Comparator mode		
Q22	P43/AIN7 and P42/AIN6 pin function selection bit (Not used for the 4513 Group)	0	P43, P42 (read/write enabled for the 4513 Group)		
		1	AIN7, AIN6/P43, P42 (read/write enabled for the 4513 Group)		
Q21	P41/AIN5 pin function selection bit (Not used for the 4513 Group)	0	P41 (read/write enabled for the 4513 Group)		
		1	AIN5/P41 (read/write enabled for the 4513 Group)		
Q20	P40/AIN4 pin function selection bit (Not used for the 4513 Group)	0	P40 (read/write enabled for the 4513 Group)		
		1	AIN4/P40 (read/write enabled for the 4513 Group)		
Comparator control register Q3 (Note 3)		at reset : 00002		at RAM back-up : state retained	R/W
Q33	Voltage comparator (CMP1) control bit	0	Voltage comparator (CMP1) invalid		
		1	Voltage comparator (CMP1) valid		
Q32	Voltage comparator (CMP0) control bit	0	Voltage comparator (CMP0) invalid		
		1	Voltage comparator (CMP0) valid		
Q31	CMP1 comparison result store bit	0	CMP1- > CMP1+		
		1	CMP1- < CMP1+		
Q30	CMP0 comparison result store bit	0	CMP0- > CMP0+		
		1	CMP0- < CMP0+		
Clock control register MR		at reset : 10002		at RAM back-up : 10002	R/W
MR3	System clock selection bit	0	f(XIN) (high-speed mode)		
		1	f(XIN)/2 (middle-speed mode)		
MR2	Not used	0	This bit has no function, but read/write is enabled.		
		1			
MR1	Not used	0	This bit has no function, but read/write is enabled.		
		1			
MR0	Not used	0	This bit has no function, but read/write is enabled.		
		1			

Notes 1: "R" represents read enabled, "W" represents write enabled.

2: Select AIN4–AIN7 with register Q1 after setting register Q2.

3: Bits 0 and 1 of register Q3 can be only read.

**PRELIMINARY**  
 Notice: This is not a final specification.  
 Some parametric limits are subject to  
 change.

Key-on wakeup control register K0		at reset : 00002		at RAM back-up : state retained	R/W
K03	Pins P12 and P13 key-on wakeup control bit	0	Key-on wakeup not used		
		1	Key-on wakeup used		
K02	Pins P10 and P11 key-on wakeup control bit	0	Key-on wakeup not used		
		1	Key-on wakeup used		
K01	Pins P02 and P03 key-on wakeup control bit	0	Key-on wakeup not used		
		1	Key-on wakeup used		
K00	Pins P00 and P01 key-on wakeup control bit	0	Key-on wakeup not used		
		1	Key-on wakeup used		
Pull-up control register PU0		at reset : 00002		at RAM back-up : state retained	R/W
PU03	Pins P12 and P13 pull-up transistor control bit	0	Pull-up transistor OFF		
		1	Pull-up transistor ON		
PU02	Pins P10 and P11 pull-up transistor control bit	0	Pull-up transistor OFF		
		1	Pull-up transistor ON		
PU01	Pins P02 and P03 pull-up transistor control bit	0	Pull-up transistor OFF		
		1	Pull-up transistor ON		
PU00	Pins P00 and P01 pull-up transistor control bit	0	Pull-up transistor OFF		
		1	Pull-up transistor ON		
Direction register FR0 (Note 2)		at reset : 00002		at RAM back-up : state retained	W
FR03	Port P53 input/output control bit	0	Port P53 input		
		1	Port P53 output		
FR02	Port P52 input/output control bit	0	Port P52 input		
		1	Port P52 output		
FR01	Port P51 input/output control bit	0	Port P51 input		
		1	Port P51 output		
FR00	Port P50 input/output control bit	0	Port P50 input		
		1	Port P50 output		

Notes 1: "R" represents read enabled, and "W" represents write enabled.

2: The 4513 Group does not have the direction register FR0.

**PRELIMINARY**  
 Notice: This is not a final specification.  
 Some parametric limits are subject to  
 change.

**ABSOLUTE MAXIMUM RATINGS**

Symbol	Parameter	Conditions		Ratings	Unit
V <sub>DD</sub>	Supply voltage			-0.3 to 7.0	V
V <sub>I</sub>	Input voltage P0, P1, P2, P3, P4, P5, $\overline{\text{RESET}}$ , X <sub>IN</sub> , VDCE			-0.3 to V <sub>DD</sub> +0.3	V
V <sub>I</sub>	Input voltage D0-D7			-0.3 to 13	V
V <sub>I</sub>	Input voltage A <sub>IN0</sub> -A <sub>IN7</sub>			-0.3 to V <sub>DD</sub> +0.3	V
V <sub>O</sub>	Output voltage P0, P1, P3, P4, P5, $\overline{\text{RESET}}$	Output transistors in cut-off state		-0.3 to V <sub>DD</sub> +0.3	V
V <sub>O</sub>	Output voltage D0-D7			-0.3 to 13	V
V <sub>O</sub>	Output voltage X <sub>OUT</sub>			-0.3 to V <sub>DD</sub> +0.3	V
P <sub>d</sub>	Power dissipation	T <sub>a</sub> = 25 °C	Package: 42P2R	300	mW
			Package: 32P6B	300	
			Package: 32P4B	1100	
Topr	Operating temperature range			-20 to 85	°C
Tstg	Storage temperature range			-40 to 125	°C

**PRELIMINARY**  
 Notice: This is not a final specification.  
 Some parametric limits are subject to  
 change.

**RECOMMENDED OPERATING CONDITIONS 1**

(Mask ROM version: Ta = -20 °C to 85 °C, VDD = 2.0 V to 5.5 V, unless otherwise noted)

(One Time PROM version: Ta = -20 °C to 85 °C, VDD = 2.5 V to 5.5 V, unless otherwise noted)

Symbol	Parameter	Conditions	Limits			Unit	
			Min.	Typ.	Max.		
VDD	Supply voltage	Mask ROM version	f(XIN) ≤ 4.2 MHz	2.5		5.5	V
		Middle-speed mode	f(XIN) ≤ 3.0 MHz	2.0		5.5	
		Mask ROM version	f(XIN) ≤ 4.2 MHz	4.0		5.5	
		High-speed mode	f(XIN) ≤ 2.0 MHz	2.5		5.5	
		High-speed mode	f(XIN) ≤ 1.5 MHz	2.0		5.5	
		One Time PROM version	f(XIN) ≤ 4.2 MHz	2.5		5.5	
		One Time PROM version	f(XIN) ≤ 4.2 MHz	4.0		5.5	
V <sub>RAM</sub>	RAM back-up voltage (at RAM back-up mode)	Mask ROM version		1.8		V	
		One Time PROM version		2.0			
V <sub>SS</sub>	Supply voltage			0		V	
V <sub>IH</sub>	"H" level input voltage	P0, P1, P2, P3, P4, P5, XIN, VDCE		0.8V <sub>DD</sub>		V <sub>DD</sub>	V
V <sub>IH</sub>	"H" level input voltage	D0-D7		0.8V <sub>DD</sub>		12	V
V <sub>IH</sub>	"H" level input voltage	RESET <sub>̄</sub>		0.85V <sub>DD</sub>		V <sub>DD</sub>	V
V <sub>IH</sub>	"H" level input voltage	CNTR0, CNTR1, SIN, SCK, INT0, INT1		0.85V <sub>DD</sub>		V <sub>DD</sub>	V
V <sub>IL</sub>	"L" level input voltage	P0, P1, P2, P3, P4, P5, D0-D7, XIN, VDCE		0		0.2V <sub>DD</sub>	V
V <sub>IL</sub>	"L" level input voltage	RESET <sub>̄</sub>		0		0.3V <sub>DD</sub>	V
V <sub>IL</sub>	"L" level input voltage	CNTR0, CNTR1, SIN, SCK, INT0, INT1		0		0.15V <sub>DD</sub>	V
I <sub>OH</sub> (peak)	"H" level peak output current	P5	V <sub>DD</sub> = 5.0 V	-20			mA
			V <sub>DD</sub> = 3.0 V	-10			
I <sub>OH</sub> (avg)	"H" level average output current	P5 (Note)	V <sub>DD</sub> = 5.0 V	-10			mA
			V <sub>DD</sub> = 3.0 V	-5			
I <sub>OL</sub> (peak)	"L" level peak output current	P3, RESET <sub>̄</sub>	V <sub>DD</sub> = 5.0 V			10	mA
			V <sub>DD</sub> = 3.0 V			4	
I <sub>OL</sub> (peak)	"L" level peak output current	D6, D7	V <sub>DD</sub> = 5.0 V			40	mA
			V <sub>DD</sub> = 3.0 V			30	
I <sub>OL</sub> (peak)	"L" level peak output current	D0-D5	V <sub>DD</sub> = 5.0 V			24	mA
			V <sub>DD</sub> = 3.0 V			12	
I <sub>OL</sub> (peak)	"L" level peak output current	P0, P1, P4, P5, SCK, SOUT	V <sub>DD</sub> = 5.0 V			24	mA
			V <sub>DD</sub> = 3.0 V			12	
I <sub>OL</sub> (avg)	"L" level average output current	P3, RESET <sub>̄</sub> (Note)	V <sub>DD</sub> = 5.0 V			5	mA
			V <sub>DD</sub> = 3.0 V			2	
I <sub>OL</sub> (avg)	"L" level average output current	D6, D7 (Note)	V <sub>DD</sub> = 5.0 V			30	mA
			V <sub>DD</sub> = 3.0 V			15	
I <sub>OL</sub> (avg)	"L" level average output current	D0-D5 (Note)	V <sub>DD</sub> = 5.0 V			15	mA
			V <sub>DD</sub> = 3.0 V			7	
I <sub>OL</sub> (avg)	"L" level average output current	P0, P1, P4, P5, SCK, SOUT (Note)	V <sub>DD</sub> = 5.0 V			12	mA
			V <sub>DD</sub> = 3.0 V			6	
ΣI <sub>OH</sub> (avg)	"H" level total average current	P5		-30			
ΣI <sub>OL</sub> (avg)	"L" level total average current	P5, D, RESET <sub>̄</sub> , SCK, SOUT				80	mA
		P0, P1, P3, P4				80	

Note: The average output current (I<sub>OH</sub>, I<sub>OL</sub>) is the average value during 100 ms.

**PRELIMINARY**  
 Notice: This is not a final specification.  
 Some parametric limits are subject to  
 change.

**RECOMMENDED OPERATING CONDITIONS 2**

(Mask ROM version: Ta = -20 °C to 85 °C, VDD = 2.0 V to 5.5 V, unless otherwise noted)

(One Time PROM version: Ta = -20 °C to 85 °C, VDD = 2.5 V to 5.5 V, unless otherwise noted)

Symbol	Parameter	Conditions		Limits			Unit	
				Min.	Typ.	Max.		
f(XIN)	Oscillation frequency (with a ceramic resonator)	Mask ROM version	VDD = 2.5 V to 5.5 V			4.2	MHz	
		Middle-speed mode	VDD = 2.0 V to 5.5 V			3.0		
		One Time PROM version	VDD = 2.5 V to 5.5 V			4.2		
		Middle-speed mode						
		Mask ROM version	VDD = 4.0 V to 5.5 V			4.2		
		High-speed mode	VDD = 2.5 V to 5.5 V			2.0		
			VDD = 2.0 V to 5.5 V			1.5		
		One Time PROM version	VDD = 4.0 V to 5.5 V			4.2		
High-speed mode	VDD = 2.5 V to 5.5 V			2.0				
f(XIN)	Oscillation frequency (with external clock input)	Mask ROM version	VDD = 2.0 V to 5.5 V			3.0	MHz	
		Middle-speed mode						
		One Time PROM version	VDD = 2.5 V to 5.5 V			3.0		
		Middle-speed mode						
		Mask ROM version	VDD = 4.0 V to 5.5 V			3.0		
			VDD = 2.5 V to 5.5 V			1.0		
		High-speed mode	VDD = 2.0 V to 5.5 V			0.8		
			One Time PROM version	VDD = 4.0 V to 5.5 V				3.0
High-speed mode	VDD = 2.5 V to 5.5 V			1.0				
tw(SCK)	Serial I/O external clock period ("H" and "L" pulse width)	Mask ROM version	VDD = 4.0 V to 5.5 V	1.5			μs	
			Middle-speed mode	VDD = 2.5 V to 5.5 V	3.0			
				VDD = 2.0 V to 5.5 V	4.0			
		One Time PROM version	VDD = 4.0 V to 5.5 V	Middle-speed mode	1.5			
				Middle-speed mode	VDD = 2.5 V to 5.5 V	3.0		
		Mask ROM version	VDD = 4.0 V to 5.5 V	High-speed mode	VDD = 2.5 V to 5.5 V	1.5		ns
					VDD = 2.0 V to 5.5 V	2.0		μs
				One Time PROM version	VDD = 4.0 V to 5.5 V	750		ns
		High-speed mode	VDD = 2.5 V to 5.5 V	1.5		μs		
		tw(CNTR)	Timer external input period ("H" and "L" pulse width)	Mask ROM version	VDD = 4.0 V to 5.5 V	1.5		
Middle-speed mode	VDD = 2.5 V to 5.5 V				3.0			
	VDD = 2.0 V to 5.5 V				4.0			
One Time PROM version	VDD = 4.0 V to 5.5 V			Middle-speed mode	1.5			
				Middle-speed mode	VDD = 2.5 V to 5.5 V	3.0		
Mask ROM version	VDD = 4.0 V to 5.5 V			High-speed mode	VDD = 2.5 V to 5.5 V	1.5		ns
					VDD = 2.0 V to 5.5 V	2.0		μs
				One Time PROM version	VDD = 4.0 V to 5.5 V	750		ns
High-speed mode	VDD = 2.5 V to 5.5 V			1.5		μs		



**PRELIMINARY**  
 Notice: This is not a final specification.  
 Some parametric limits are subject to  
 change.

**ELECTRICAL CHARACTERISTICS**(Mask ROM version:  $T_a = -20\text{ }^\circ\text{C}$  to  $85\text{ }^\circ\text{C}$ ,  $V_{DD} = 2.0\text{ V}$  to  $5.5\text{ V}$ , unless otherwise noted)(One Time PROM version:  $T_a = -20\text{ }^\circ\text{C}$  to  $85\text{ }^\circ\text{C}$ ,  $V_{DD} = 2.5\text{ V}$  to  $5.5\text{ V}$ , unless otherwise noted)

Symbol	Parameter	Test conditions		Limits			Unit	
				Min.	Typ.	Max.		
VOH	"H" level output voltage P5	VDD = 5 V	IOH = -10 mA	3			V	
		VDD = 3 V	IOH = -5 mA	2				
VOL	"L" level output voltage P0, P1, P4, P5	VDD = 5 V	IOL = 12 mA			2	V	
		VDD = 3 V	IOL = 6 mA			0.9		
VOL	"L" level output voltage P3, $\overline{\text{RESET}}$	VDD = 5 V	IOL = 5 mA			2	V	
		VDD = 3 V	IOL = 2 mA			0.9		
VOL	"L" level output voltage D6, D7	VDD = 5 V	IOL = 30 mA			2	V	
			IOL = 10 mA			0.9		
		VDD = 3 V	IOL = 15 mA			2	V	
			IOL = 5 mA			0.9		
VOL	"L" level output voltage D0-D5	VDD = 5 V	IOL = 15 mA			2	V	
		VDD = 3 V	IOL = 3 mA			0.9		
I <sub>IH</sub>	"H" level input current P0, P1, P2, P3, P4, P5, $\overline{\text{RESET}}$ , VDCE	Vi = VDD, port P4 selected, port P5: input state				1	$\mu\text{A}$	
I <sub>IH</sub>	"H" level input current D0-D7	Vi = 12 V				1	$\mu\text{A}$	
I <sub>IL</sub>	"L" level input current P0, P1, P2, P3, P4, P5, $\overline{\text{RESET}}$ , VDCE	Vi = 0 V No pull-up of ports P0 and P1, port P4 selected, port P5: input state		-1			$\mu\text{A}$	
I <sub>IL</sub>	"L" level input current D0-D7	Vi = 0 V		-1			$\mu\text{A}$	
IDD	Supply current	at active mode	VDD = 5 V	f(XIN) = 4.0 MHz	1.8	5.5	mA	
			Middle-speed mode		f(XIN) = 400 kHz	0.5		1.5
			VDD = 3 V	f(XIN) = 4.0 MHz	0.9	2.7		
			Middle-speed mode		f(XIN) = 400 kHz	0.2		0.6
			VDD = 5 V	f(XIN) = 4.0 MHz	3.0	9.0		
			High-speed mode		f(XIN) = 400 kHz	0.6		1.8
			VDD = 3 V	f(XIN) = 2.0 MHz	0.9	2.7		
			High-speed mode		f(XIN) = 400 kHz	0.3		0.9
		at RAM back-up mode		Ta = 25 °C		0.1	1	$\mu\text{A}$
				VDD = 5 V			10	
		VDD = 3 V			6			
RPU	Pull-up resistor value	VDD = 5 V	Vi = 0 V	20	50	125	k $\Omega$	
		VDD = 3 V		40	100	250		
VT+ - VT-	Hysteresis INT0, INT1, CNTR0, CNTR1, SIN, SCK	VDD = 5 V			0.3		V	
		VDD = 3 V			0.3			
VT+ - VT-	Hysteresis $\overline{\text{RESET}}$	VDD = 5 V			1.5		V	
		VDD = 3 V			0.6			

**PRELIMINARY**  
 Notice: This is not a final specification.  
 Some parametric limits are subject to  
 change.

**A-D CONVERTER RECOMMENDED OPERATING CONDITIONS**

(Comparator mode included, Ta = -20 °C to 85 °C, unless otherwise noted)

Symbol	Parameter	Conditions	Limits			Unit
			Min.	Typ.	Max.	
VDD	Supply voltage		2.7		5.5	V
VIA	Analog input voltage		0		VDD	V
f(XIN)	Oscillation frequency	Middle-speed mode, VDD ≥ 2.7 V	0.8			MHz
		High-speed mode, VDD ≥ 2.7 V	0.4			MHz

**A-D CONVERTER CHARACTERISTICS**

(Ta = -20 °C to 85 °C, unless otherwise noted)

Symbol	Parameter	Test conditions	Limits			Unit
			Min.	Typ.	Max.	
-	Resolution				10	bits
-	Linearity error	Ta = 25 °C, VDD = 2.7 V to 5.5 V			±2	LSB
		Ta = -25 °C to 85 °C, VDD = 3.0 V to 5.5 V				
-	Differential non-linearity error	Ta = 25 °C, VDD = 2.7 V to 5.5 V			±0.9	LSB
		Ta = -25 °C to 85 °C, VDD = 3.0 V to 5.5 V				
V0T	Zero transition voltage	VDD = 5.12 V	0	5	20	mV
		VDD = 3.072 V	0	3	15	
VFST	Full-scale transition voltage	VDD = 5.12 V	5105	5115	5125	mV
		VDD = 3.072 V	3060	3069	3075	
IADD	A-D operating current	VDD = 5.0 V      f(XIN) = 0.4 MHz to 4.0 MHz		0.7	2.0	mA
		VDD = 3.0 V      f(XIN) = 0.4 MHz to 2.0 MHz		0.2	0.4	
TCONV	A-D conversion time	f(XIN) = 4.0 MHz, Middle-speed mode			93.0	μs
		f(XIN) = 4.0 MHz, High-speed mode			46.5	
-	Comparator resolution	Comparator mode			8	bits
-	Comparator error (Note)	VDD = 5.12 V			±20	mV
		VDD = 3.072 V			±15	
-	Comparator comparison time	f(XIN) = 4.0 MHz, Middle-speed mode			12	μs
		f(XIN) = 4.0 MHz, High-speed mode			6	

Note: As for the error from the ideal value in the comparator mode, when the contents of the comparator register is n, the logic value of the comparison voltage Vref which is generated by the built-in DA converter can be obtained by the following formula.

Logic value of comparison voltage Vref

$$V_{ref} = \frac{V_{DD}}{256} \times n$$

n = Value of register AD (n = 0 to 255)

**VOLTAGE DROP DETECTION CIRCUIT CHARACTERISTICS**

(Ta = -20 °C to 85 °C, unless otherwise noted)

Symbol	Parameter	Test conditions	Limits			Unit
			Min.	Typ.	Max.	
VRST	Detection voltage		2.7		4.1	V
		Ta = 25 °C	3.3	3.5	3.7	
IRST	Operation current of voltage drop detection circuit	VDD = 5.0 V		50	100	μA

**PRELIMINARY**  
 Notice: This is not a final specification.  
 Some parametric limits are subject to change.

**VOLTAGE COMPARATOR RECOMMENDED OPERATING CONDITION**

(Ta = -20 °C to 85 °C, unless otherwise noted)

Symbol	Parameter	Conditions	Limits			Unit
			Min.	Typ.	Max.	
VDD	Supply voltage		3.0		5.5	V
VINCMP	Voltage comparator input voltage	VDD = 3.0 V to 5.5 V	0.3VDD		0.7VDD	V
tCMP	Voltage comparator response time	VDD = 3.0 V to 5.5 V			20	μs

**VOLTAGE COMPARATOR CHARACTERISTICS**

(Ta = -20 °C to 85 °C, VDD = 3.0 V to 5.5 V, unless otherwise noted)

Symbol	Parameter	Test conditions	Limits			Unit
			Min.	Typ.	Max.	
-	Comparison decision voltage error	CMP0- > CMP0+, CMP0- < CMP0+ CMP1- > CMP1+, CMP1- < CMP1+		20	100	mV
ICMP	Voltage comparator operation current	VDD = 5.0 V		15	50	μA

**BASIC TIMING DIAGRAM**

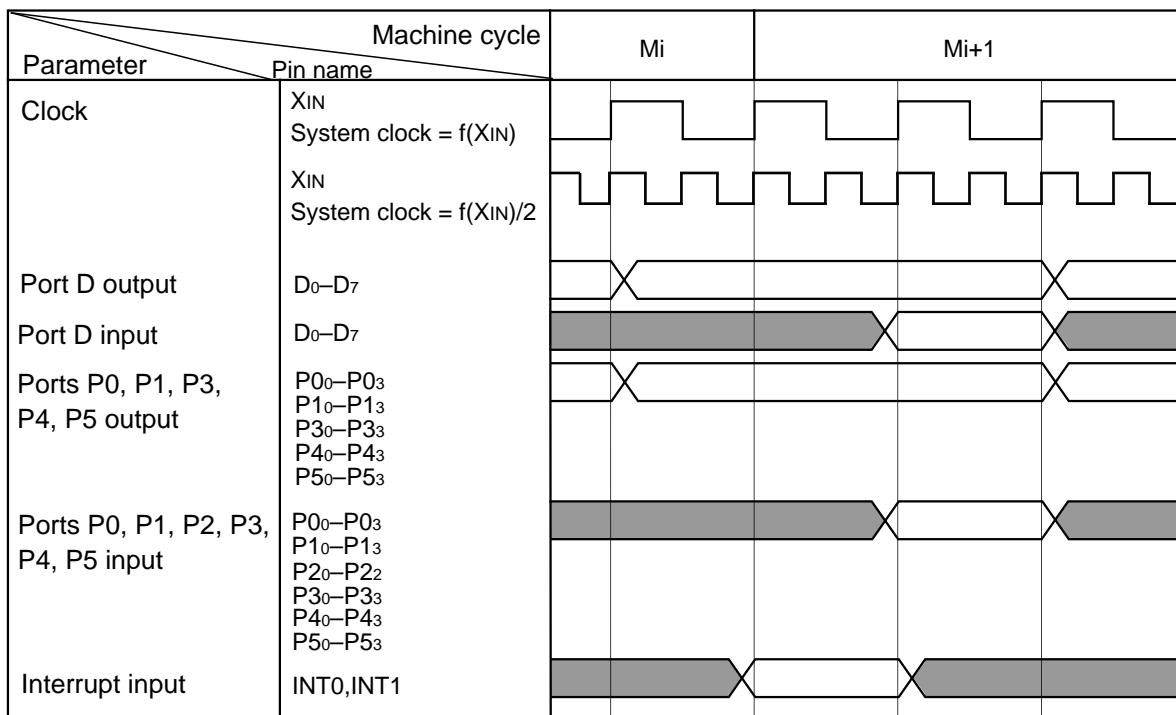

**PRELIMINARY**  
 Notice: This is not a final specification.  
 Some parametric limits are subject to change.

**BUILT-IN PROM VERSION**

In addition to the mask ROM versions, the 4513/4514 Group has programmable ROM version software compatible with mask ROM. The built-in PROM of One Time PROM version can be written to and not be erased.

The built-in PROM versions have functions similar to those of the mask ROM versions, but they have PROM mode that enables writing to built-in PROM.

Table 25 shows the product of built-in PROM version. Figure 49 and 50 show the pin configurations of built-in PROM versions.

**Table 25 Product of built-in PROM version**

Product	PROM size (X 10 bits)	RAM size (X 4 bits)	Package	ROM type
M34513E4SP/FP	4096 words	256 words	SP: 32P4B FP: 32P6B-A	One Time PROM version [shipped in blank]
M34513E8FP	8192 words	384 words	32P6B-A	
M34514E8FP	8192 words	384 words	42P2R-A	

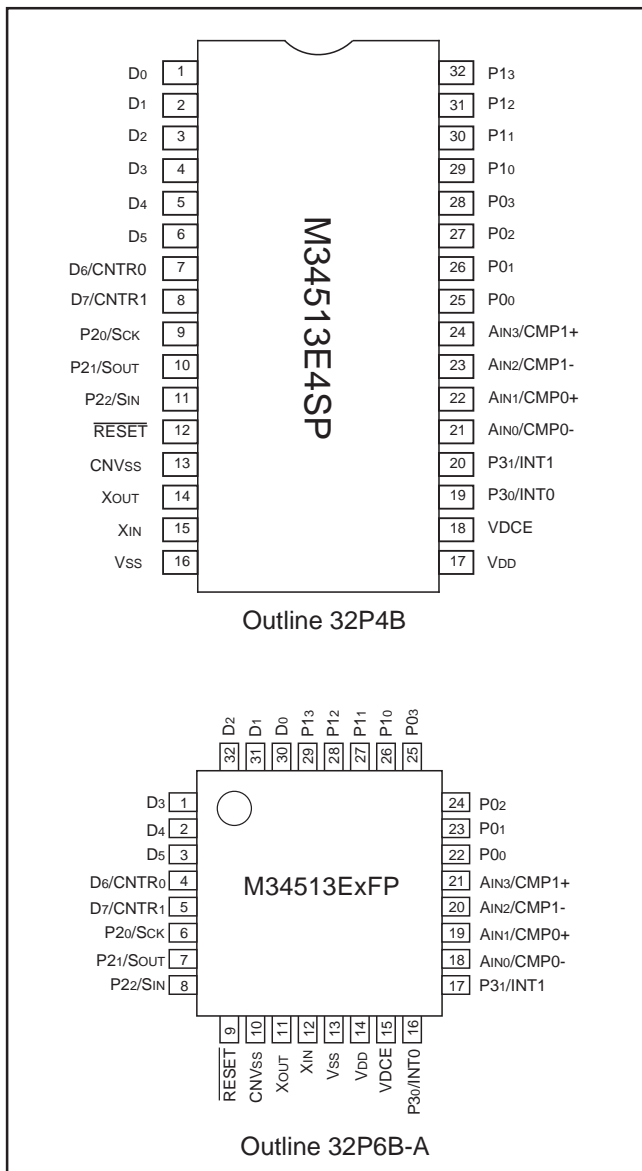

**Fig. 49 Pin configuration of built-in PROM version of 4513 Group**

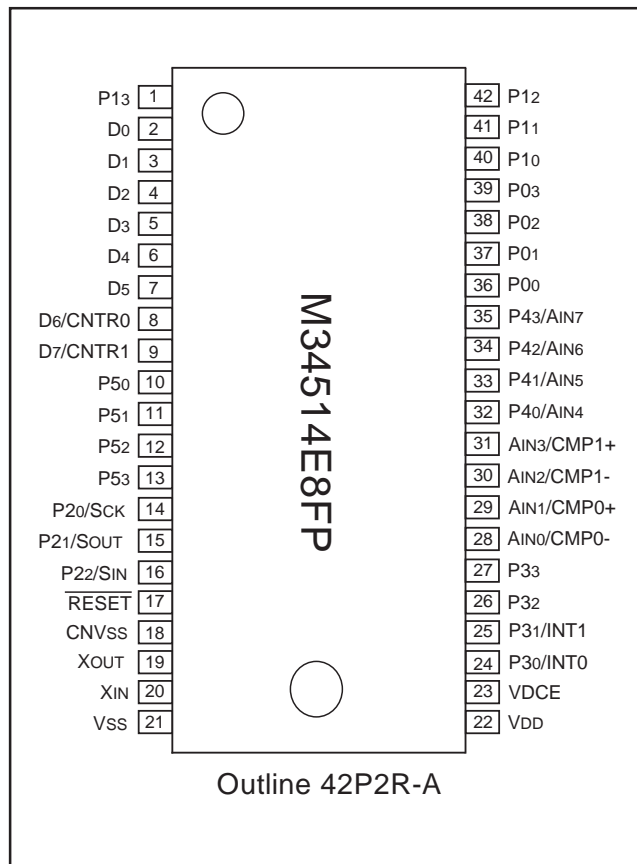

**Fig. 50 Pin configuration of built-in PROM version of 4514 Group**

**PRELIMINARY**  
 Notice: This is not a final specification.  
 Some parametric limits are subject to change.

**(1) PROM mode**

The built-in PROM version has a PROM mode in addition to a normal operation mode. The PROM mode is used to write to and read from the built-in PROM.

In the PROM mode, the programming adapter can be used with a general-purpose PROM programmer to write to or read from the built-in PROM as if it were M5M27C256K. Programming adapters are listed in Table 26. Contact addresses at the end of this sheet for the appropriate PROM programmer.

- Writing and reading of built-in PROM

Programming voltage is 12.5 V. Write the program in the PROM of the built-in PROM version as shown in Figure 51.

**(2) Notes on handling**

- ① A high-voltage is used for writing. Take care that overvoltage is not applied. Take care especially at turning on the power.
- ② For the One Time PROM version shipped in blank, Mitsubishi Electric corp. does not perform PROM writing test and screening in the assembly process and following processes. In order to improve reliability after writing, performing writing and test according to the flow shown in Figure 52 before using is recommended (Products shipped in blank: PROM contents is not written in factory when shipped).

**Table 26 Programming adapters**

Microcomputer	Programming adapter
M34513E4SP	PCA7442SP
M34513E4FP, M34513E8FP	PCA7442FP
M34514E8FP	PCA7441

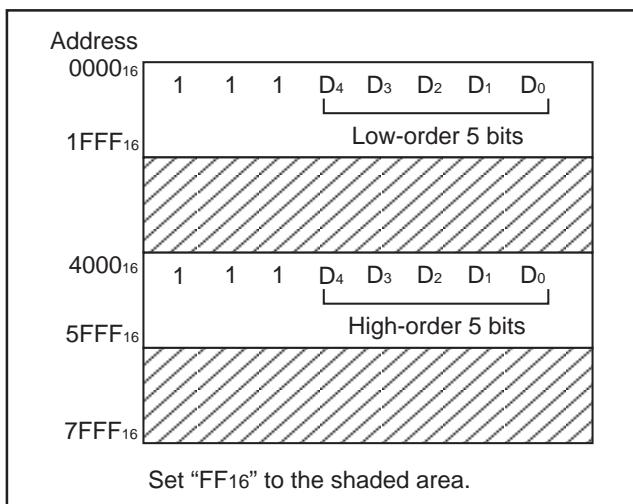

**Fig. 51 PROM memory map**

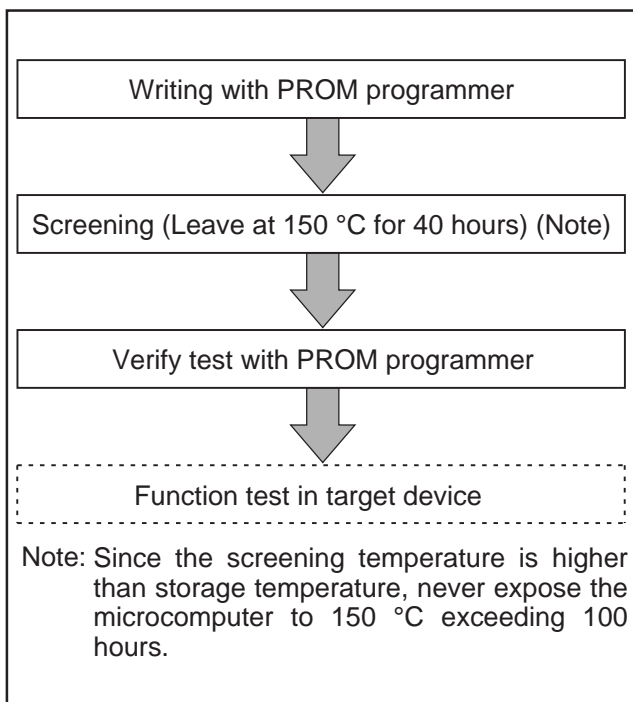

**Fig. 52 Flow of writing and test of the product shipped in blank**















**PRELIMINARY**  
 Notice: This is not a final specification.  
 Some parametric limits are subject to change.

**32P4B (32-PIN SHRINK DIP) MARK SPECIFICATION FORM**

Mitsubishi IC catalog name

Please choose one of the marking types below (A, B, C), and enter the Mitsubishi IC catalog name and the special mark (if needed).

**A. Standard Mitsubishi Mark**

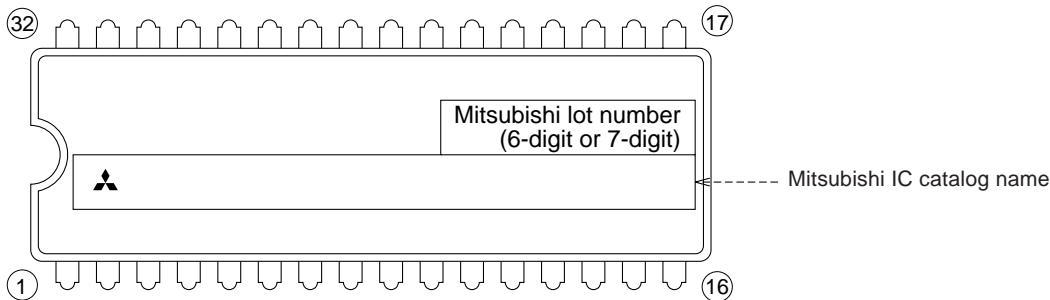

**B. Customer's Parts Number + Mitsubishi catalog name**

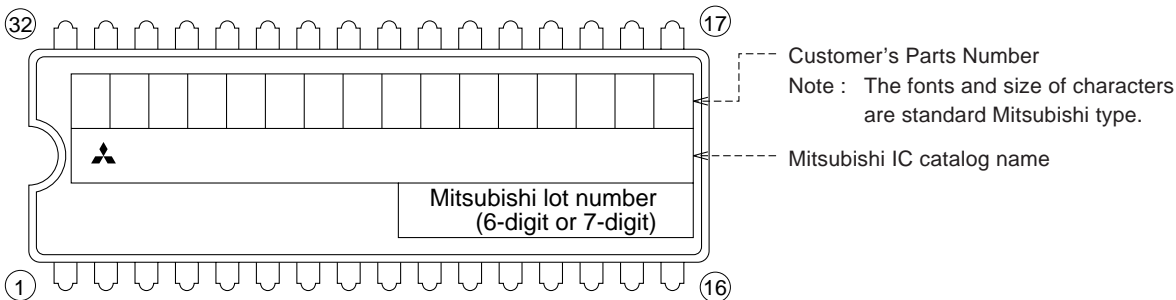

Note1 : The mark field should be written right aligned.

- 2: The fonts and size of characters are standard Mitsubishi type.
- 3: Customer's Parts Number can be up to 16 characters : Only 0 ~ 9, A ~ Z, +, -, /, (, ), &, @, . (periods), and , (commas) are usable.
- 4: If the Mitsubishi logo is not required, check the box on the right.

Mitsubishi logo is not required

**C. Special Mark Required**

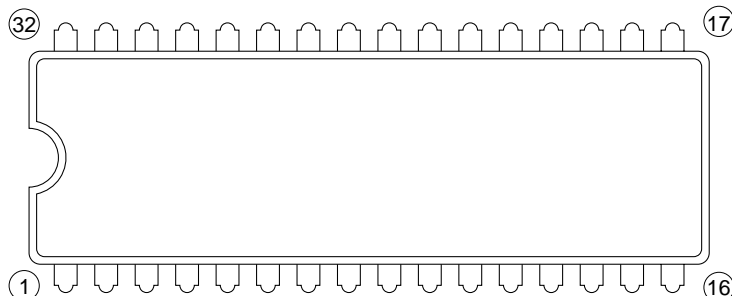

Note1 : If the Special Mark is to be Printed, indicate the desired layout of the mark in the upper figure. The layout will be duplicated as close as possible. Mitsubishi lot number (6-digit or 7-digit) and Mask ROM number (3-digit) are always marked.

- 2: If the customer's trade mark logo must be used in the Special Mark, check the box on the right. Please submit a clean original of the logo. For the new special character fonts a clean font original (ideally logo drawing) must be submitted.
- 3: The standard Mitsubishi font is used for all characters except for a logo.

Special logo required

**PRELIMINARY**  
 Notice: This is not a final specification.  
 Some parametric limits are subject to change.

**32P6B (32-PIN LQFP) MARK SPECIFICATION FORM**

Mitsubishi IC catalog name

Please choose one of the marking types below (A, B), and enter the Mitsubishi catalog name and the special mark (if needed).

**A. Standard Mitsubishi Mark**

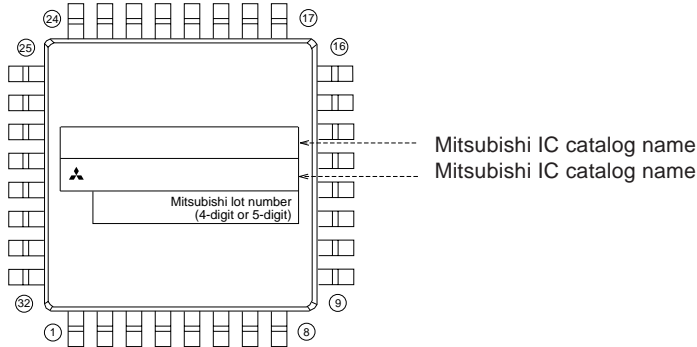

**B. Customer's Parts Number + Mitsubishi catalog name**

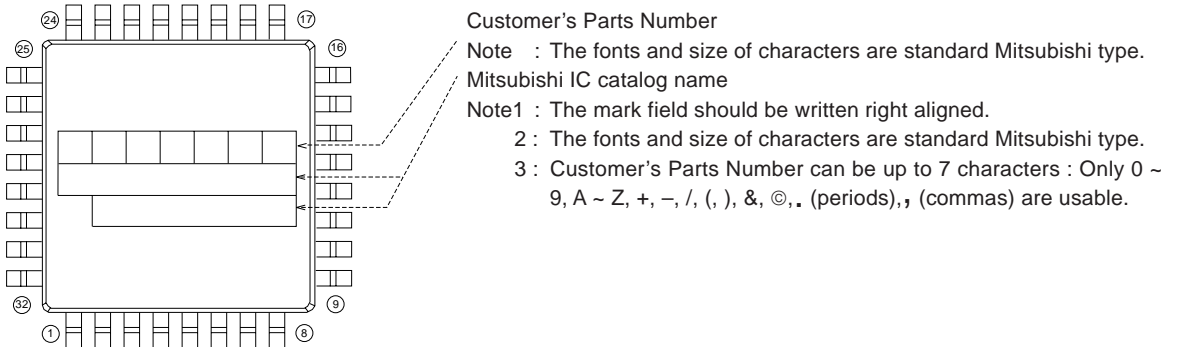

**42P2R-A (42-PIN SHRINK SOP) MARK SPECIFICATION FORM**

Mitsubishi IC catalog name

Please choose one of the marking types below (A, B, C), and enter the Mitsubishi catalog name and the special mark (if needed).

**A. Standard Mitsubishi Mark**

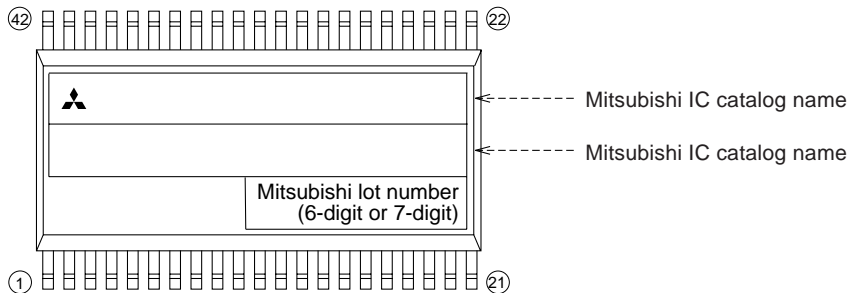

**B. Customer's Parts Number + Mitsubishi catalog name**

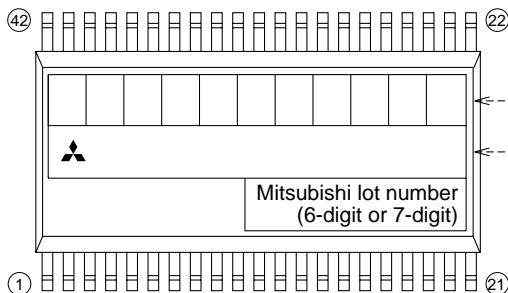

- Customer's Parts Number
- Note : The fonts and size of characters are standard Mitsubishi type.
- Mitsubishi IC catalog name
- Note1 : The mark field should be written right aligned.
- 2 : The fonts and size of characters are standard Mitsubishi type.
- 3 : Customer's Parts Number can be up to 11 characters : Only 0 ~ 9, A ~ Z, +, -, /, (, ), &, @, . (periods), , (commas) are usable.
- 4 : If the Mitsubishi logo is not required, check the box below.

Mitsubishi logo is not required

**C. Special Mark Required**

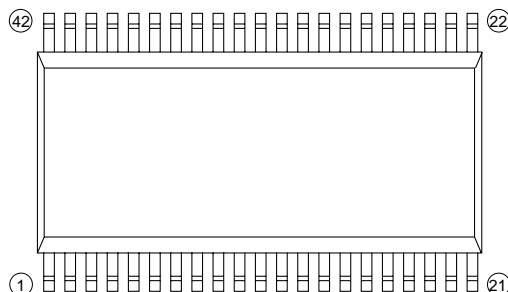

- Note1 : If the Special Mark is to be Printed, indicate the desired layout of the mark in the left figure. The layout will be duplicated as close as possible.
- Mitsubishi lot number (6-digit or 7-digit) and Mask ROM number (3-digit) are always marked.
- 2 : If the customer's trade mark logo must be used in the Special Mark, check the box below.
- Please submit a clean original of the logo.
- For the new special character fonts a clean font original (ideally logo drawing) must be submitted.

Special logo required

**PRELIMINARY**  
 Notice: This is not a final specification.  
 Some parametric limits are subject to  
 change.

**PACKAGE OUTLINE**

**32P4B**

Plastic 32pin 400mil SDIP

EIAJ Package Code SDIP32-P-400-1.78	JEDEC Code -	Weight(g) 2.2	Lead Material Alloy 42/Cu Alloy
--	-----------------	------------------	------------------------------------

Symbol	Dimension in Millimeters		
	Min	Nom	Max
A	-	-	5.08
A1	0.51	-	-
A2	-	3.8	-
b	0.35	0.45	0.55
b1	0.9	1.0	1.3
b2	0.63	0.73	1.03
c	0.22	0.27	0.34
D	27.8	28.0	28.2
E	8.75	8.9	9.05
e	-	1.778	-
e1	-	10.16	-
L	3.0	-	-
θ	0°	-	15°

**32P6B-A**

Plastic 32pin 7X7mm body LQFP

EIAJ Package Code LQFP32-P-77-0.80	JEDEC Code -	Weight(g)	Lead Material Alloy 42
---------------------------------------	-----------------	-----------	---------------------------

Symbol	Dimension in Millimeters		
	Min	Nom	Max
A	-	-	1.7
A1	0	0.1	0.2
A2	-	1.4	-
b	0.3	0.35	0.45
c	0.105	0.125	0.175
D	6.9	7.0	7.1
E	6.9	7.0	7.1
e	-	0.8	-
Hd	8.8	9.0	9.2
HE	8.8	9.0	9.2
L	0.3	0.5	0.7
L1	-	1.0	-
y	-	-	0.1
θ	0°	-	10°
b2	-	0.5	-
l2	1.0	-	-
MD	-	7.4	-
ME	-	7.4	-

**PRELIMINARY**  
 Notice: This is not a final specification.  
 Some parametric limits are subject to  
 change.

**42P2R-A**

**Plastic 42pin 450mil SSOP**

EIAJ Package Code	JEDEC Code	Weight(g)	Lead Material
SSOP42-P-450-0.80	-	0.63	Alloy 42/Cu Alloy

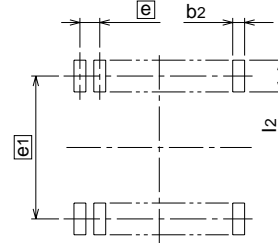
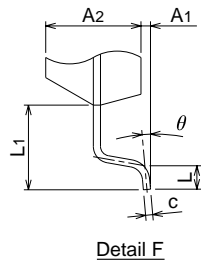
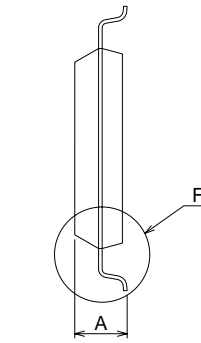
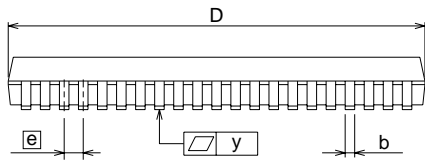
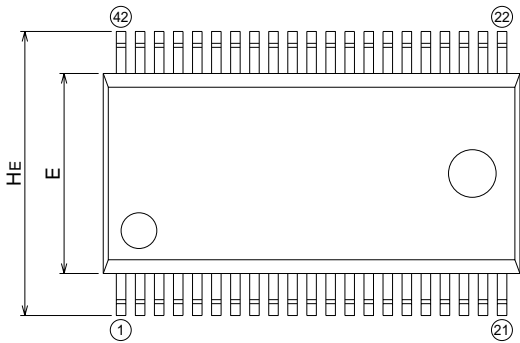

Recommended Mount Pad

Symbol	Dimension in Millimeters		
	Min	Nom	Max
A	-	-	2.4
A1	0.05	-	-
A2	-	2.0	-
b	0.35	0.4	0.5
c	0.13	0.15	0.2
D	17.3	17.5	17.7
E	8.2	8.4	8.6
e	-	0.8	-
HE	11.63	11.93	12.23
L	0.3	0.5	0.7
L1	-	1.765	-
y	-	-	0.15
$\theta$	0°	-	10°
b2	-	0.5	-
e1	-	11.43	-
l2	1.27	-	-

Detail F



**Keep safety first in your circuit designs!**

- Mitsubishi Electric Corporation puts the maximum effort into making semiconductor products better and more reliable, but there is always the possibility that trouble may occur with them. Trouble with semiconductors may lead to personal injury, fire or property damage. Remember to give due consideration to safety when making your circuit designs, with appropriate measures such as (i) placement of substitutive, auxiliary circuits, (ii) use of non-flammable material or (iii) prevention against any malfunction or mishap.

**Notes regarding these materials**

- These materials are intended as a reference to assist our customers in the selection of the Mitsubishi semiconductor product best suited to the customer's application; they do not convey any license under any intellectual property rights, or any other rights, belonging to Mitsubishi Electric Corporation or a third party.
- Mitsubishi Electric Corporation assumes no responsibility for any damage, or infringement of any third-party's rights, originating in the use of any product data, diagrams, charts or circuit application examples contained in these materials.
- All information contained in these materials, including product data, diagrams and charts, represent information on products at the time of publication of these materials, and are subject to change by Mitsubishi Electric Corporation without notice due to product improvements or other reasons. It is therefore recommended that customers contact Mitsubishi Electric Corporation or an authorized Mitsubishi Semiconductor product distributor for the latest product information before purchasing a product listed herein.
- Mitsubishi Electric Corporation semiconductors are not designed or manufactured for use in a device or system that is used under circumstances in which human life is potentially at stake. Please contact Mitsubishi Electric Corporation or an authorized Mitsubishi Semiconductor product distributor when considering the use of a product contained herein for any specific purposes, such as apparatus or systems for transportation, vehicular, medical, aerospace, nuclear, or undersea repeater use.
- The prior written approval of Mitsubishi Electric Corporation is necessary to reprint or reproduce in whole or in part these materials.
- If these products or technologies are subject to the Japanese export control restrictions, they must be exported under a license from the Japanese government and cannot be imported into a country other than the approved destination.  
Any diversion or reexport contrary to the export control laws and regulations of Japan and/or the country of destination is prohibited.
- Please contact Mitsubishi Electric Corporation or an authorized Mitsubishi Semiconductor product distributor for further details on these materials or the products contained therein.

REVISION DESCRIPTION LIST

4513/4514 GROUP DATA SHEET

Rev. No.	Revision Description	Rev. date
1.0	First Edition	980807